

LOHANA SCHOOLS
BRIDGE TO P.7 MATHEMATICS EXAMINATION 2020

Name:

School: Stream:

READ THE INSTRUCTIONS CAREFULLY;

- ▶ This examination paper comprises **two** sections. Section **A** and section **B**.
- ▶ Section **A** has **20** questions, hence **40** marks, **2** mark each.
- ▶ Section **B** has **15** questions, **60** marks .Marks for each question in section **B** are indicated against the respective questions. Please answer **all** questions in **both** sections.
- ▶ Answer(s) for every question must be written in the spaces provided.
- ▶ All answers should be written in **GOOD HANDWRITING, WELL FORMED DIGITS AND WELL FORMED LETTERS.**
- ▶ Any unclear work, crossed work, work written in unbearable handwriting, or poorly formed digits, will not be awarded any marks.
- ▶ Any answer provided without clear **M**athematical working or procedures, will not be awarded any marks.
- ▶ You are encouraged to use a pencil where necessary, and blue ink pen is recommendable for use when answering.

..... **GOOD LUCK**

F I N A L S U B J E C T S C O R E

SECTION A

SECTION B

TOTAL MARK

TEACHER'S COMMENT.

.....

SECTION A (40 MARKS)

1. Workout: 23×3

2. In the Venn- diagram below, describe the **unshaded** part.

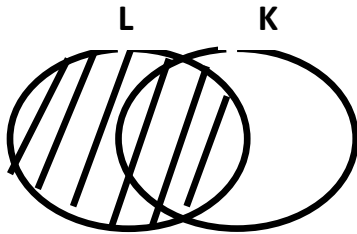

3. Write **X C V I I** in **words**.

4. If $a = 3$, $b = 5$ and $c = 2$, find the value of $\frac{acb}{a + c}$

5. Find the **sum** of the next **two** numbers in the sequence

12 , 10 , 13 , 11 , 14 , ,

6. Workout: $\frac{2}{3} + \frac{1}{4}$

7. The **bearing** of town **A** from town **B** is **320°**. Find the **bearing** of town **B** from town **A**

8. The temperature of a patient is **37°C**. If it drops by **5°C**, find the new temperature of the patient

9. Using a pair of compasses, a **sharp** Pencil and a ruler only, accurately construct an angle of **60°** in the space provided below.

10. Find the number that has been expanded to give;

$$(4 \times 10^3) + (2 \times 10^1) + (6 \times 10^0)$$

11. Below is an **isosceles triangle**. Workout the value of **K**.

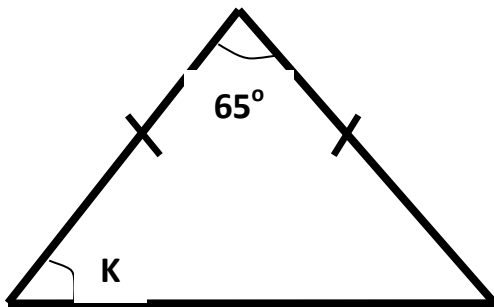

12. **Amos** withdrew some bank notes from **Equity** bank numbered consecutively from **PH 0 9 4 5 5 8** to **PH 0 9 4 6 4 7**, each note worth **twenty thousand shillings**. Find the number of bank notes he withdrew.

13. Below is a compass direction. Study it and answer the questions that follow.

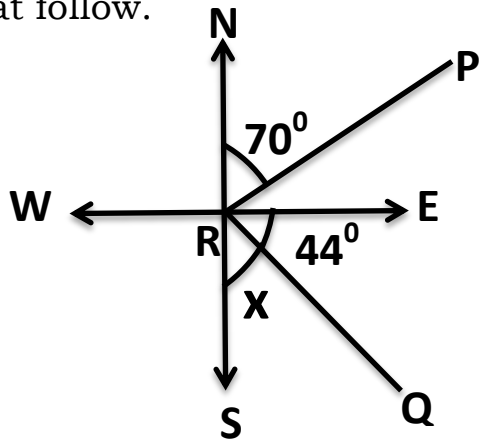

(a). Find the size of angle marked x

(b). Find the direction of **P** from **R**

14. There are **five elements** in set **C** Calculate the number of **sub sets** in set **P**

15. The **volume** of the cuboid below is **240 cm^3** . Find the height (**h**) of the cuboid.

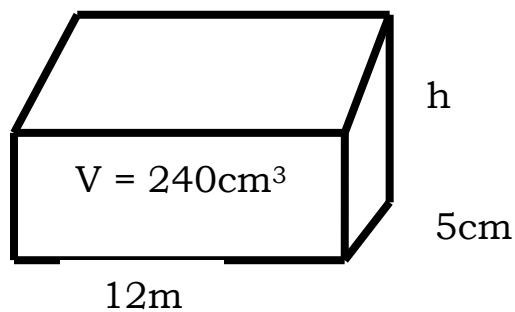

16. Workout the **L.C.M** of **8** and **24**.

17. A motorist drove at a speed of **60km/hr.** from **Masaka** to **Kampala** for **3 hrs.** Calculate the distance from **Masaka** to **Kampala**.

18. In the figure below, \overline{MN} is parallel to \overline{PQ} . Find the value of **P**

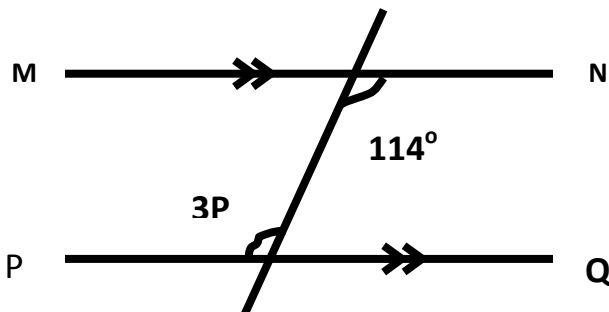

19. Change 1101_{two} to base **ten**.

20. Below is a regular **hexagon**. Show and write the number of lines of folding symmetry of the polygon.

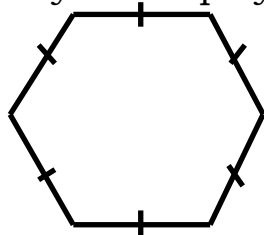

SECTION B (60 marks).

Marks for each question are indicated in brackets against the question

21. The Venn-diagram below shows the number of pupils who Participate in **Swimming (S)** and **Volley ball (V)**. Study it carefully.

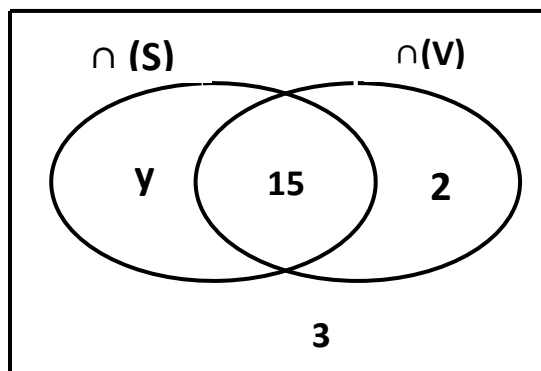

(a). If there are **45** pupils altogether, find the value of **y**. (**2 marks**).

(b). How many pupils participate in **only one** game? (**2 marks**).

(c). Find the probability of picking a pupil who **does not** participate in Swimming at all. (**1 mark**).

22. Given that, the exchange rates for **1 US** dollar to **Ug.sh** is **3,600** and **1 K.sh = Ug.sh 30**.

(a). If **Amon** has **Ug.sh. 7,200,000** and wants to go to **USA**, how many dollars will he get after the money exchange? (**2 marks**).

(b).Last week, **Aujo** came back from **Kenya** with **50,000 Kenya shillings**.
how much in **Uganda shillings** did she get? (**2 marks**).

23. The pie-chart shows the grades scored by **180** candidates in a **Kidawalume primary school in P.L.E 2020**. Study it carefully and answer the questions.

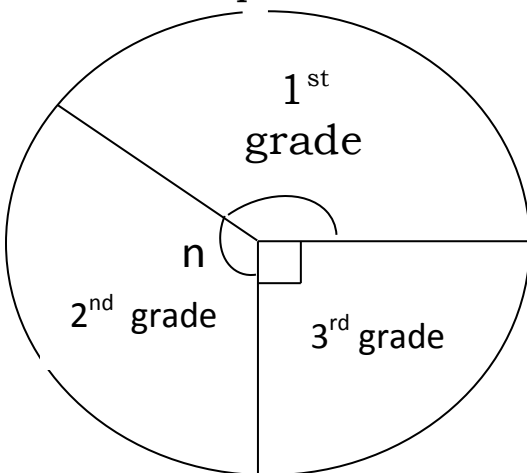

(a).Find the value of **n** (**2 marks**).

(b).How many candidates passed in **1st grade** altogether? (**2 marks**).

(c).What **fraction** of the total number of candidates passed in **3rd grade**?
(**1 mark**).

	<i>Km</i>	<i>M</i>		<i>Hrs</i>	<i>Min</i>
24. Workout:	2	400	(a) +	4	20
	3	700		2	50
	_____			_____	
	(2 marks).			(2 marks).	

(c).A cyclist covered a journey in **150 minutes**. How many **hours** did he take to cover the same journey? (2 marks).

25. In a **P.6** class of **80** pupils, $\frac{3}{4}$ of them are girls and the rest are boys.

(a).What fraction of the pupils are **boys**? (2 marks).

(b).How many **girls** are in class? (2 marks).

(c).Express the number of **boys** as a percentage of the total number of pupils in the class. (2 marks).

26. The diagram below shows the prime factors of y and prime factors of 30.

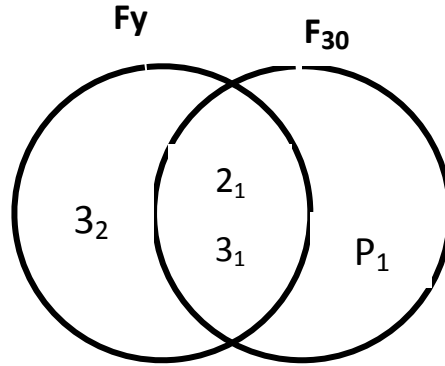

(a). Find the value of (i) Y (1 mark).

(ii) P (1 mark).

(b). Work out the L.C.M of y and 30. (2 marks).

(c). Find the G.C.F of 30 and y . (2 marks).

27. Ramona bought the following items from Kyanja market.

3 litres of cooking oil at sh. 4,000 a litre.

4 bars of soap at sh. 16,000.

500 gm of sugar at sh. 3,000 each kg.

1 $\frac{1}{2}$ kg of Maize flour at sh. 2,000 per kg.

(a).Workout this **Ramona's total bill.**

(4 marks).

(b).Calculate the amount she had if she remained with a change of

Sh. 7,000.

(1 mark).

28. A student scored the following marks in a series of tests.

60 , 90 , 50 , 60 and 40.

(a).Find the **median** mark.

(2 marks).

(b).Find the **average** mark.

(2 marks).

(c).In how many tests did the student score marks **below** the **mean** mark

(2 marks).

29. Below is a **parallelogram**. Study it carefully and answer the questions

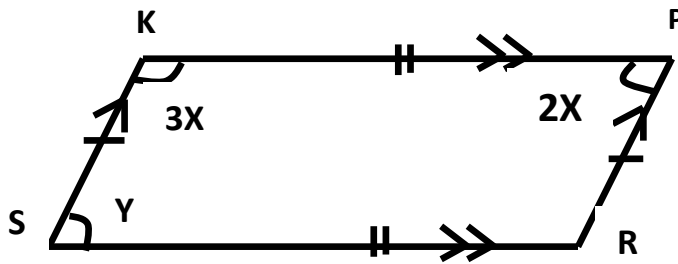

(a). Find the value of **x** **(2 marks)**

(b). Find the size of angle **y** **(2 marks)**

(c). How many lines of folding **symmetry** has the figure above
 **(1 mark)**

30. Dhuruti deposited **sh. 600,000** to a savings bank account which offers simple rate of **20% per annum** for a period of **2 years**.

(a). Calculate the **simple interest**. **(2 marks)**

(b). Work out the amount after **2 years**. **(2 marks)**

31.(a). Simplify; $2y + 3p - y + 4p$

(2 mark).

(b).Solve: $3n - 4 = 8$

(2 marks).

32. Using a sharp pencil, a ruler and a pair of compasses only,

Construct a **rectangle PQRS**. Where $\overline{PQ} = 6cm$ and $\overline{RS} = 4cm$ **(4 marks).**

(b).Measure length \overline{PR} in cm.....(1 mark)

Xxxxxxxx E N D xxxxxxxxxxxxxx

LOHANA SCHOOLS
BRIDGE TO P.7 ENGLISH EXAMINATION 2020

Name:

School: **Stream:**

Read the following instructions carefully

- ☞ The paper is made up of two Sections: **A** and **B**.
- ☞ Section **A** has **50** questions (**50 marks**).
- ☞ Section **B** has **5** questions (**50 marks**).
- ☞ **All** working must be done using a blue or black ball point or fountain pen. Only diagram should be drawn in pencil.
- ☞ **Unnecessary** changes of work may lead to loss of marks.
- ☞ **Any** handwriting that cannot easily be read may lead to loss of marks.

FOR OFFICIAL USE ONLY:	
SECTION A:	
SECTION B:	
TOTAL	

Teacher's comment:

.....

.....

.....

Section A:

Use the correct form of the word in brackets to complete the sentences.

1. Letter is a very interesting topic in Primary Seven.
(write)

2. Teachers have organized lessons for all the candidates. (remedy)

3. Of the twins, Babirye is the (clever)

4. One must respect all the time. (one)

5. This paper is for purposes so, I must do it very well. (promote)

Fill in the blank spaces with a suitable word.

6. of the two boys is your son?

7. I logged in, I couldn't join the lesson.

8. an expensive car this is!

9. I did not kill the monkey it destroyed my maize.

10. COVID-19 is a very disease.

Re-write the sentences giving the opposite of the underlined word.

11. I lost my dictionary last term.

.....

12. Poaching a legal activity in Uganda.

.....

13. That waitress is my cousin.

.....

14. Most roads in Uganda are wide.

.....

15. Log in before talking to Teacher Albert.

.....

Re-arrange these words in ABC order.

16. waiter, waiting, wait, waitress
.....

17. debate, debater, debating, debated
.....

Write the following short forms in full.

18. I'd - 19. He's -

20. can't -

Construct meaningful sentences using these words to show that you know their meaning.

21. rich -

22. reach -

Write the plural form of these words.

23. commander-in-chief -

24. thesaurus - 25. luggage -

Re-write the sentences giving one word for the underlined group of words.

26. My aunt bought me a new book that gives meaning and pronunciation of words.
.....

27. We visited a place where animals are slaughtered.
.....

28. The man who looks after goats is my grandpa.
.....

Arrange the words below to make correct sentences.

29. going the you are restaurant to?
.....

30. cartoons watching in interested girls are.

Re-write the sentences as instructed in the brackets.

31. By whom has this bed been made? (**B**egin: Who.....?)

.....

32. There is no difference between these two laptops.

(**R**e-write and end:similar)

.....

33. Mrs. Nanono repaired my phone. I paid her ten thousand shillings.

(**B**egin: Having.....)

.....

34. A week has seven days. (**B**egin: There.....)

.....

35. I met a lady. She was from Ireland. She was short and black.

(**R**e-write without any conjunction)

.....

36. "I will spend my Christmas with my uncle," said Angel.

(**B**egin: Angel said that ...)

.....

37. Boys are kind. Girls are also kind. (**U**se..... as well as.....)

.....

38. Immediately I boarded the train, it started raining. (**B**egin: No sooner.....)

.....

39. I joined the lesson. I saw the teacher. (**U**se.....as soon as.....)

.....

40. Lamich does not run as fast as Austin. (**U**se.....than.....)

.....

41. If we wear face masks, we shall not contract **COVID 19**. (**B**egin: Unless)

.....

42. Close that window,?

(Complete sensibly)

43. Good candidates should not make noise in the classroom.

(Use.....keep.....)

.....

44. It isn't necessary for Omara to unmute. (Use.....needn't.....)

.....

45. That is the hotel. My mother works there. (Use.....where.....)

.....

46. Nobody helped Patel to cross the road. (Re-write and end: herself)

.....

47. Friday comes before Saturday. (Use..... after...)

.....

48. Samantha is such a polite girl that all the teachers love her. (Use.....so...that...)

.....

49. All the candidates study online. (Begin: None.....)

.....

50. First come, (Complete sensibly).

Section B:

51. Read the passage carefully and then answer the questions that follow in full sentences.

ACCIDENTS IN UGANDA

Accidents in Uganda are very common in that many people have lost their lives and others have got permanent injuries.

Some causes of road accidents are; careless drivers, drivers who are drunk, bad roads, speeding, vehicles in a bad mechanical condition and illiterate drivers.

However, the traffic police is fighting hard to ensure that our roads are very safe especially for the young ones in order to secure their future.

Questions

1. Write the **title** of the passage.

.....

2. What is the **passage** about?

.....

3. Mention **one** cause of road accidents.

.....

4. **Who** is fighting hard to ensure that our roads are safe?

.....

5. Who are **illiterate** drivers?

.....

6. Give **one** word to mean people walking along the road.

.....

7. **What** do you think should be done to drivers who are drunk?

.....

8. How many **causes** of road accidents have been mentioned in the passage?

.....

9. Give the opposite of;-

a). **Common** -

10. What **lesson** have you learnt from the passage?

.....

52. Read the advertisement below and then answer questions that follow in full sentences.

**MELLISA RESTAURANT AND TAKEAWAY LIMITED
LOCATED IN MASAKA CITY ON NKONDO ROAD, WOULD
LIKE TO HIRE TWO CHEFS, FOUR WAITERS AND ONE
WAITRESS.**

**QUALIFICATIONS ARE: BELOW TWENTY YEARS AND YOU
MUST SPEAK ENGLISH FLUENTLY.**

**BY: MANAGEMENT.
1st October, 2021**

Questions

- a. What is the advertisement about?
.....
- b. In which **city** is that restaurant?
.....
- c. How many waitresses are needed?
.....
- d. When was the advertisement written?
.....
- e. Who wrote that advertisement?
.....
- f. Mention **one** qualification for the jobs.
.....
- g. Nakasi only speaks French. Will she be hired?
.....
- h. Give another word to mean
 - i). **hire** -
 - ii). **fluently** -
 - iii). What is a **restaurant**?

54. Complete the composition below about ONLINE LESSONS using the words given in the list.

LIST OF WORDS

normal	learner	network
closure	login	interesting
access	virtual	computer
	calendars	

..... classes are lessons conducted online by various schools. This can be done using a, tablet or any other gadget.

Teachers make which act as timetables and every is connected to the system in order to to the lessons.

Online lessons are very but at times if the is faulty, one is unable to

Finally, due to the continuous of schools, studying online is now the new

LOHANA SCHOOLS
BRIDGE TO P.7 SCIENCE EXAMINATION 2020

Name:

School: **Stream:**

Read the following instructions carefully

- ☞ The paper is made up of two Sections: **A** and **B**.
- ☞ Section **A** has **40** questions (**40 marks**).
- ☞ Section **B** has **15** questions (**60 marks**).
- ☞ **Unnecessary** changes of work and any handwriting that cannot easily be read may lead to loss of marks.

FOR OFFICIAL USE ONLY:	
SECTION A:	
SECTION B:	
TOTAL	

Teacher's comment:

.....

.....

.....

SECTION A (40 Marks)

1. Mention the **component** of air needed for photosynthesis.

.....

2. Identify any **one** way in which vices can be controlled on poultry farm.

.....

3. How are **mammals** different from other groups of vertebrates?

.....

4. How do conifers reproduce?

.....

5. Give any **one** reason why it is advisable to raise a rabbit hutch slightly above the ground.

6. Write down any **one** symptom of **COVID-19**.

.....

7. Below is a state of matter.

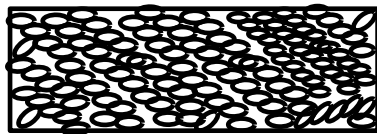

How does heat travel through the above state of matter?

.....

8. Name the **sense** organ for touch.

.....

9. Identify any **one** way in which food is important to the human body.

.....

10. Why is it good to soak clothes before washing them?

.....

11. State any **one** way in which bacteria and fungi are harmful in the environment.

.....

12. Mention any **one** factor that affects the pitch of sound.

.....

13. Why is it hard for urban cattle keepers to use free range system of grazing?

.....

14. State any **one** way of caring for a pregnant woman.

.....

15. Write down the element of **PHC** that helps parents to carryout child spacing properly.

.....

16. Write **ABC** in full in relation to accidents and first aid.

.....

17. Mention any **one** way in which proper sanitation prevents outbreak of diarrhoeal diseases in the community.

.....

The diagram below is an intestinal worm. Use it to answer question 18.

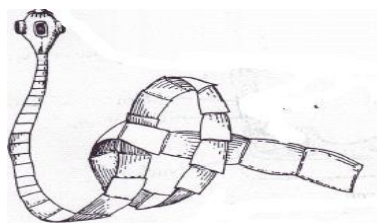

18. How can parents protect their children from contracting the above worm?

.....

19. Name any **one** root crop pest.

.....

20. How does the practice of clearing bushes around homes protect family members from malaria?

.....

21. Why is the **dry** season the best period for harvesting crops?

.....

22. State any **one** way of conserving soil.

.....

23. Why do health workers prescribe drugs before giving them to patients?

.....

24. Identify any **one** way in which the sun is used as a resource in the environment.

.....

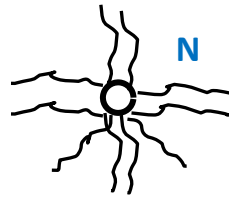

25. How is seed in fruit **M** likely to be dispersed?

.....

26. Give any **one** adaptation of seed **N** to its mode of dispersal.

.....

27. How are the teeth important during the process of digestion?

.....

28. State any **one** way in which an **HIV** positive mother can prevent spreading the virus to her unborn baby.

.....

29. How are cross breeds of animal obtained?

.....

30. Identity any **one** problem of a family may face due to improper use of a latrine.

.....

31. How does a guitar produce sound?

.....

32. Give any **one** way in which cigarette smoking affects, the human lungs.

.....

33. Mention any **one** way in which school health committee is important.

.....

34. How are the earthworms important to crop farmers?

.....

35. What happens to pure water if it is boiled up to **100°C**?

.....

36. Why should the hole of the **VIP** latrine be left open all times?

.....

37. Name the major product obtained from **Angora** goats.

.....

38. Mention any **one** way in which natural changes are harmful to the environment.

.....

39. Why should tepid sponging be carried out on a person with high fever?

.....

40. Name the vaccine that is given to babies of **36 weeks** of age.

.....

SECTION B (60 Marks)

41 a) Apart from ticks, give any **two** other cattle parasites.

(i)..... (ii).....

b) Mention any **one** disease spread by ticks among cattle.

.....

c) How can a cattle farmer control tick- borne diseases on his farm?

.....

.....

42a) Use the diagram of the blood vessels below to answer the questions that follow.

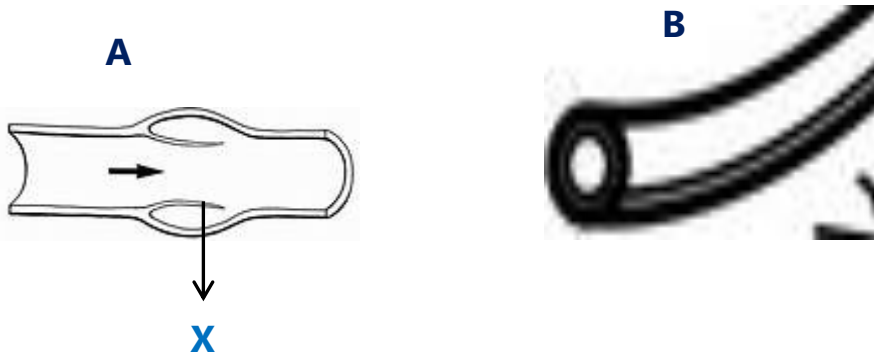

a) Identify the type of blood vessel **B**

.....
.....

b) How are the structures **X** important in blood vessel **A**?

.....
.....

c) What **type** of blood is mainly carried by blood vessel ?

.....
.....

d) State a reason why blood vessel **B** is made of thick walls.

.....
.....

43) Use the list of the organisms below to answer the questions that follow.

(MOTH, GOAT, SLUG, FISH, BAT)

a) Mention the **two** organisms that can be grouped together.

(i).....

(ii).....

b) Give a reason to support your answer in (a) above

.....
.....

c) How is a fish **different** from other animals in the above list.

.....
.....

d) In which way is a moth useful to man?

.....
.....

44a) State any **one** main cause of dehydration in children.

.....

b) Mention any **one** sign of dehydration

.....
.....

c) Why should a dehydrated person be given **ORS**?

.....
.....

d) Give a reason why a person preparing **ORS** should first wash hands?

.....
.....

45) Complete the table below by filing in the missing information.

CLASS OF FOOD	SOURCES
(i).....	Beans, eggs, meat
Carbohydrates	(ii).....
iii).....	Fruits, green vegetables
Rough age	iv).....

46a) What is seed dispersal?

.....
.....

b) Give any **two** agents of seed dispersal

(i)..... (ii).....

c) In which way is seed dispersal important in the environment?

.....
.....

47a) What is near drowning?

.....
.....

b) State any **two** ways of administering first aid to a near drowned victim

(i)

(ii)

c) How can near drowning be prevented among children?

.....
.....

48) **The diagram below shows a method of finding the volume of an irregular object. Study it carefully and answer the questions that follow.**

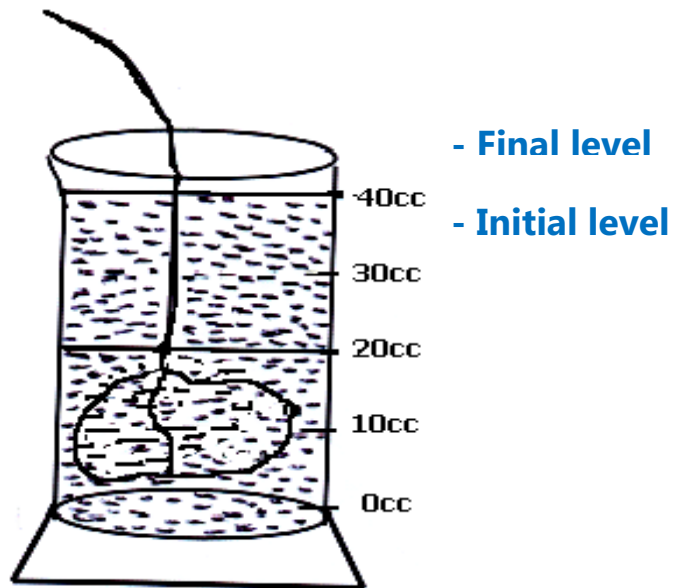

a) Name the method used to find the volume of a stone above.

.....
.....

b) Work out the **volume** of the stone. **(2 marks)**

c) Why does the stone sink in water?

.....

49a) How does sound travel from the teacher to the pupils' ears in class?

.....
.....

b) State any **one** factor that affects the speed of sound.

.....
.....

c) Which of the drums below will produce the **highest** pitch when hit?

.....

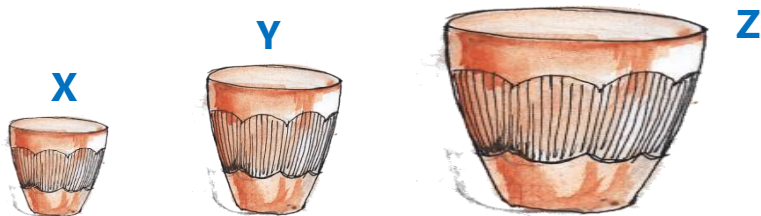

d) Give a reason to support your answer in **(c)** above.

.....
.....

50a) Mention any **two** examples of spore bearing non flowering plants

(i).....

(ii).....

b) In which way do conifers conserve the environment?

.....

c) Give any **one** example of conifers?

.....

51 **The diagram below shows a method of making alcohol. Use it to answer the questions that follow.**

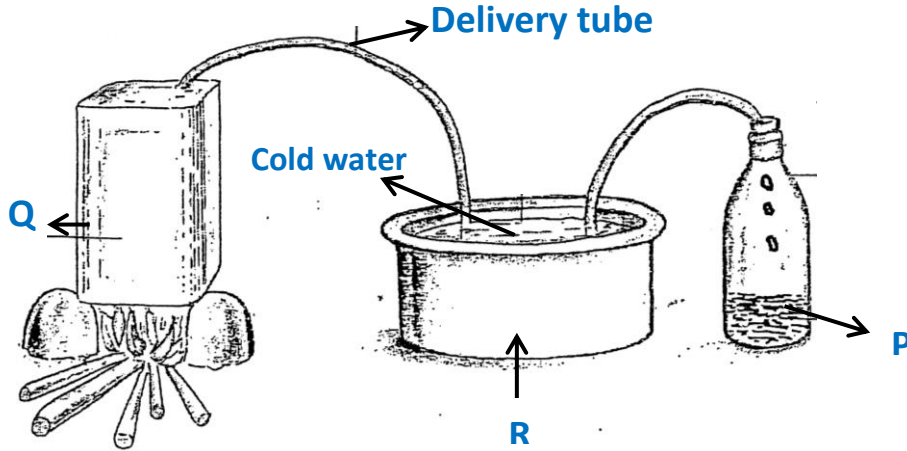

a) Name the **method** of making alcohol shown in the diagram above.

.....

b) Which physical processes are taking place at positions **R** and **Q**?

R..... **Q**.....

c) How does alcoholism affect a community?

.....
.....

52a) Mention the **type** of teeth used for:

i) Tearing flesh.....

ii) Biting food.....

b) State any **two** ways of caring for our teeth

i).....

ii).....

53a) How are the following features useful our a **VIP** latrine?

(i) Vent pipe.....

(ii) Screen.....

b) Why should a pit latrine be constructed **30m** away from the water source?

.....
.....

c) Give **one** advantage of **ECOSAN** latrine over other types of latrines.

.....

54) **Match the following body organs to their functions**

Body organ

Function

Liver

Stores urine

Kidneys

Helps in gaseous exchange

Lungs

Regulates blood sugar

Bladder

Filters blood.

a. The liver

.....

b. The kidneys

.....

c. The lungs

.....

d. The bladder

.....

55a) Mention any **one** biological change in the environment that requires oxygen to take place

.....

b) Give any **two** examples of chemical changes

(i).....

(ii).....

c) How are chemical changes similar to biological changes?

.....

END

LOHANA SCHOOLS
BRIDGE TO P.7 SOCIAL STUDIES EXAMINATION 2020

NAME:.....

SCHOOL:.....STREAM:.....

Read the instructions carefully.

- The paper is made up of two sections: A and B.
- Section A has 40 questions (40 marks)
- Section B has 15 questions (60 marks)
- Unnecessary changes of work and any handwriting that cannot easily be read may lead to loss of marks.

FOR OFFICIAL USE ONLY

SECTION A	
SECTION B	
TOTAL	

Section A: (40 marks)

1. Name any one landlocked member state of the East African Community.

2. Mention any one type of scale used on maps.

3. Give any one way political leaders promote peace in an area.

4. State any one common problem faced by people living in low land areas.

5. Give any one reason why Uganda is divided into districts.

6. Name any one tribe under the Highland Nilotes in East Africa.

7. Compare Mount Kilimanjaro and Mount Elgon in terms of their formation.

8. Give any one reason the government is encouraging people to start up the Savings and Credit Cooperative Organisation (SACCOs)?

9. What does the road sign below symbolize?

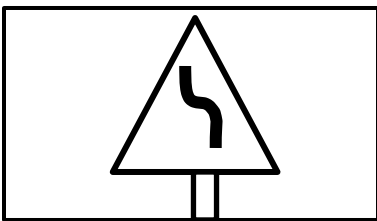

10. Name the waterway that separates Lake Edward from Lake George?

11. State any one way a community is important to people in the school.

12. Give any one reason why the colonialists introduced the growing of cash crops in East Africa.

13. How is the sun useful in the rain cycle?

14. Mention any one example of non-biodegradable wastes in the environment.

15. Why is Jomo Kenyatta regarded to be a national hero in Kenya?

16. State any reason why Miombo woodlands of central Tanzania is sparsely populated.

17. Name any one source of material in the environment that can be used to make local crafts.

18. State any one way the activity of bush burning is a threat to Uganda's tourism industry.

19. How was the LEGCO useful to the British colonialists in Uganda?

20. Give any one way people can safeguard themselves against rain weather.

21. Which country was formerly mandated to Belgians among East African Community member states?

22. Give any one way citizens can promote law and order in the community where they live.

23. Why did the Portuguese build Fort Jesus along the coast of East Africa?

24. State any one way a good road network promotes trade in an area.

25. Mention any one feature that creates a natural boundary between Uganda and the Democratic Republic of Congo.

26. Give one way waterfalls along river Nile have promoted economic development in Uganda.

27. Why are minerals regarded to be non-renewable resources?

28. Give one reason why Nyanza province was transferred to Kenya by the British colonialists.

29. Name the major crop grown on Doho irrigation scheme.

30. State any one cause of a by-election in a country.

31. Give one reason why a national population census in Uganda is conducted every after ten years.

32. In which way does drought cause famine in an area?

33. Name the first railway line to be built in East Africa?

34. Give the meaning of population density.

35. State any one way a national constitution is important to a country.

For each of the questions 36 to 40, answer Either Christianity or Islamic in one number.

36. Either: What was the sign of the covenant God made with Noah?

Or: Write down any one symbol of Islam.

37. Either: Give any one way the Holy Spirit is important to Christians.

Or: Give any one way congregational prayers are important to Muslims.

38. Either: How is Baptism important in Christianity?

Or: How is taking of Shahada important in Islamic faith?

39. Either: Name the African country where Jesus has ever lived.

Or: Name the country where Prophet Mohammad was born.

40. Either: Give one reason why Christians are always encouraged to reconcile with one another.

Or: State any one reason why Islam encourages reconciliation among Muslims.

Section B. (60 Marks)

41. a) Which tribe formed Wanga kingdom in Kenya?

b) Give any two advantages of kingdoms to a country.

i) _____

ii) _____

c) How did the 1967 constitution affect kingdoms in Uganda?

42. a) Which type of climate is described as hot and wet throughout the year?

b)Mention any one suitable economic activity carried out in the above type of climate.

c)Give one way climate influences people's dressing style?

d)Which aspect of climate mainly influences human settlement?

43. Study the map below and use it to answer the questions that follow.

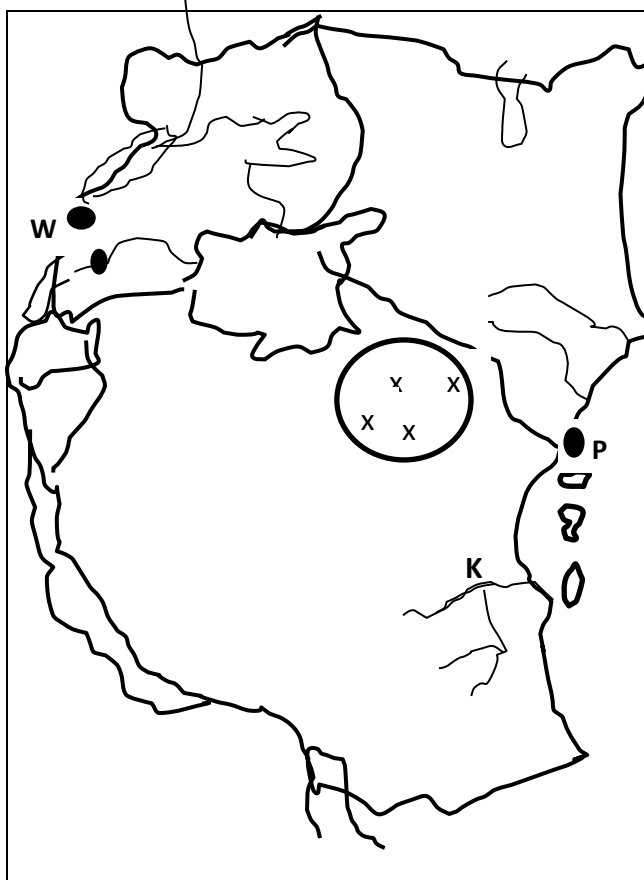

a)Name the national park marked XXX.

b)Why is it shorter to travel by air from Port P to town W?

c)Name the river marked K.

d)Give one way port marked P has promoted development in Kenya.

44. a)Name any one rebellion that was staged against the German colonialists in Tanganyika.

b)Give any one cause of Africans' resistance against the German colonialists in Tanganyika.

c)How was Kabaka Mwanga similar to Omukama Kabalega during colonial rule?

d)Why was African resistance against the colonialists easily defeated?

45. Match the information in list A with that given in list B correctly.

<u>List A</u>	<u>List B</u>
Pyrethrum	For making cement
Phosphates	For making glasses
Limestone	For making insecticides
Soda ash	Used for making artificial fertilizers

Correct order

Pyrethrum _____

Phosphates _____

Limestone _____

Soda ash _____

46. a)Which flag was replaced by the Uganda National Flag?

b)How do Ugandans treat the national flag during a national mourning?.

c)Why do Ugandans carry the Uganda national flag when representing the country in international games?

d) What does yellow colour symbolize on the Uganda national flag?

47. a) Name any one of the founders of the EAC in 1967.

b) Give any two reasons why the EAC was formed.

i) _____

ii) _____

c) How is Arusha important to the East Africa Community?

48. a) Which system of colonial administration was mainly used by the British in Uganda?

b) Give any one reason why British colonialist used the above system.

c) State any one way African traditional leaders were helpful to the British colonialists.

d) Name any one colonial collaborator in Uganda.

49. a) Mention one of the 5Rs used in waste management.

b) State any two dangers caused by poor waste management in the environment.

i) _____

ii) _____

c) Give any one way rubbish is commonly managed in schools.

50. The diagram below is of a deficit budget. Study it carefully and use it to answer the questions that follow.

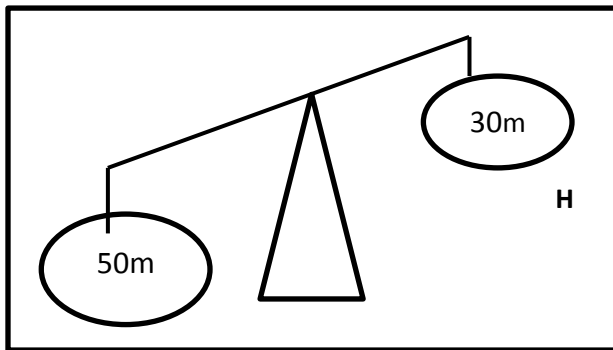

a) Name the part marked H.

b) Give a reason for your answer in (a) above.

c) State any one problem a country with the above type of budget is likely to face.

d) Apart from a deficit budget, mention any one other type of budget.

For each of the questions 51 to 50, answer. Either Christianity Or Islamic questions but not Both. No marks will be given to a candidate who attempts both alternatives in one number.

51. Either: a) Who is a Martyr?

b) Name the first Christian martyr according to the Bible.

c)How did most Christian martyrs in Uganda meet their death?

d)Give any one lesson learnt from the Uganda martyrs.

Or: a)Who is a Muslim convert?

b)Give any two ways the early Muslim converts were persecuted.

i)

ii)

c)Mention any one lesson learnt from the early Muslim converts.

52. Either: a) Name the first group of people to know about Jesus' birth.

b)Mention any one gift that was brought to baby Jesus by the Magi.

c)Why did Joseph and Mary go to Bethlehem.

d)How did the birth of Jesus benefit Christians today?

Or: a)Mention any two things that are considered to be unclean according Islam.

b) Why is it necessary for a Muslim to perform ablution before salat?

c) Apart from ablution, give one other way Muslims prepare for salat.

53. Either: a) Give any one reason why Christians worship the Lord God.

b) State any two benefits a Christian enjoys from worshipping God the Lord God.

i) _____

ii) _____

c) Which commandment of God encourages Christians to worship God alone?

Or: a) Give any one reason why Muslims worship Allah.

b) State any two benefits a Muslim enjoys from worshipping Allah.

i) _____

ii) _____

c) Write down the first pillar of Islam.

54. Either: a) Who led the Israelites out of Egypt?

b) Which book in the Bible explains the journey of the Israelites out of Egypt?

c)Mention any one problem that was faced by the Israelites during the above journey.

d)Give one reason why God wanted the Israelites to leave Egypt.

Or: a)Who led the Ban Israel out of Misri?

b) Which holy book was revealed to the above prophet?

c) Mention any one problem that was faced by the Ban-Israel on their way from Misri.

d)Give one reason why Allah wanted the Ban-Israel to leav Misri.

55. FOR BOTH

a)Give two ways a Christian/Muslim can show kindness to people he/she lives with.

i)_____

ii)_____

b)Mention any one group of people who should be cared for.

c)Give one reason why it is always important for one to care for other people.

End