

WEEK I

Monday

1. **Write the words correctly.**

- (a) b\_\_ \_\_ k                      (b) p\_\_n\_\_il  
(c)                                      (d)

2. **Use a correct word to fill the gaps.**

- (a) Tom \_\_\_\_\_ reading a book.  
(b) She \_\_\_\_\_ a big bag.  
(c) He is eating \_\_\_\_\_ egg.  
(d) The boys \_\_\_\_\_ playing.  
(e) We use a \_\_\_\_\_ to write in our books.

3. **Arrange the words in alphabetical order.**

- (a) nurse, cook, bursar

---

- (b) bus, big, bag

---

Tuesday

1. **Write the words correctly.**

- (a) vife: \_\_\_\_\_                      (b) serun: \_\_\_\_\_  
(c) ylap: \_\_\_\_\_                      (d) nelcip: \_\_\_\_\_

2. **Use the given words to write sentences.**

- (a) two: \_\_\_\_\_

(b) to: \_\_\_\_\_

3. **Re-arrange the words to form sentences.**

(a) pot is in The a flower.

\_\_\_\_\_

(b) your Who teacher is?

\_\_\_\_\_

(c) has Mary box a.

\_\_\_\_\_

Wednesday

1. **Write the words correctly.**

(a) ensur: \_\_\_\_\_ (b) nevse: \_\_\_\_\_

(c) tetra: \_\_\_\_\_ (d) licecr: \_\_\_\_\_

2. **Use 'These', 'This', 'a', 'an', 'is' or 'are' to fill the gaps.**

(a) She is eating \_\_\_\_\_ orange.

(b) \_\_\_\_\_ is a book.

(c) The boys \_\_\_\_\_ reading.

(d) He is writing with \_\_\_\_\_ pencil.

(e) \_\_\_\_\_ are flowers.

(f) A cow \_\_\_\_\_ an animal.

3. **Use the correct form of the word in brackets to fill the gaps.**

(a) The dogs \_\_\_\_\_ eating meat. (is)

(b) The girls \_\_\_\_\_ balls. (has)

(c) I \_\_\_\_\_ a boy. (is)

Thursday

1. **Arrange the words into sentences.**

(a) animal A is an cow.

\_\_\_\_\_

(b) is Jane food eating.

\_\_\_\_\_

(c) live does Where Ali?

\_\_\_\_\_

2. **Give the plural form of the underlined word.**

(a) The teacher has a box. \_\_\_\_\_

(b) That is a cat. \_\_\_\_\_

(c) He goes to church on Sunday. \_\_\_\_\_

3. **Use a correct word to fill the gaps in the sentences.**

(a) Tom eats \_\_\_\_\_ orange every morning.

(b) Teachers use \_\_\_\_\_ to write on the  
blackboard.

(c) The bird is flying \_\_\_\_\_ the tree.

(d) The boys \_\_\_\_\_ playing football.

(e) \_\_\_\_\_ does Sarah live?

Friday

1. **Circle the different word.**

(a) ten, write, three, eight

(b) chair, stool, bench, stone

2. **Complete the sentences about the pictures.**

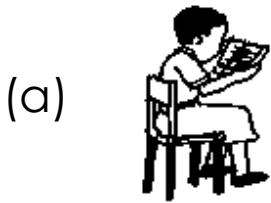

Mary is \_\_\_\_\_ a book.



The cat is \_\_\_\_\_ the table.

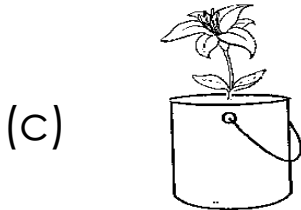

The \_\_\_\_\_ is in the tin

3. **Use a capital letter to rewrite the sentence.**

(a) this is a tree.

\_\_\_\_\_

(b) Give the book to mariam.

\_\_\_\_\_

WEEK II

Monday

1. **Fill the gaps in the story with the given words.**

**( lives, teacher , father, is , He)**

David \_\_\_\_\_ a boy. \_\_\_\_\_ is nine years old.

He \_\_\_\_\_ at Ndeeba. His \_\_\_\_\_ is

Mr. Muntu. He is a \_\_\_\_\_.

2. **Match correctly.**

- (a) Tom is \_\_\_\_\_ trees.
- (b) These are \_\_\_\_\_ writing in a book.
- (c) One plus two \_\_\_\_\_ to learn.
- (d) We go to school \_\_\_\_\_ equals three.

3. **Read the story and answer the questions.**

My name is Ali. I am a boy. I am six years old. I go to Kampi Primary School. I am in P. 1. I live at Mende.

My father is Mr. Matu. He is a teacher.

**Questions:**

- (a) What is the name of the boy in the story?

\_\_\_\_\_

- (b) How old is Ali?

\_\_\_\_\_

- (d) Where does Ali live?

\_\_\_\_\_

(e) In which class is Ali?

---

Tuesday

1. **Use the words to write sentences.**

(a) cut

---

(b) cat

---

2. **Use a correct word to fill the gaps in the sentences.**

(a) Tom \_\_\_\_\_ a bag.

(b) The girl \_\_\_\_\_ reading a book.

(c) The flowers are \_\_\_\_\_ the tin.

(d) She is eating \_\_\_\_\_ egg.

(e) The boys \_\_\_\_\_ playing football.

(f) \_\_\_\_\_ is Jane doing?

3. **Use 'is', 'are', 'a', 'an', 'these', 'this' or 'who' to fill the gaps.**

(a) Ali has \_\_\_\_\_ orange.

(b) \_\_\_\_\_ are books.

(c) The dogs \_\_\_\_\_ eating meat.

(d) Mary has \_\_\_\_\_ pencil.

(e) \_\_\_\_\_ sweeps the classroom?

Wednesday

1. **Arrange the words into sentences.**

(a) is cow a This.

\_\_\_\_\_

(b) book is reading Juma a.

\_\_\_\_\_

(c) doing is Peter What?

\_\_\_\_\_

2. **Use the correct form of the word in brackets to fill the gaps.**

(a) She is \_\_\_\_\_ food. (eat)

(b) I \_\_\_\_\_ a boy. (is)

(c) \_\_\_\_\_ are pens. (This)

(d) \_\_\_\_\_ sweeping the compound. (his)

(e) The girls \_\_\_\_\_ a ball. (has)

3. **Write in capital letters.**

(a) chalk: \_\_\_\_\_ (b) basket: \_\_\_\_\_

Thursday

1. **Give the plural form of the underlined word.**

(a) She is sitting on a chair. \_\_\_\_\_

(b) This is a leaf. \_\_\_\_\_

(c) He tells a story every day \_\_\_\_\_

(d) They come to school by bus. \_\_\_\_\_

2. **Use a question mark, a full stop or a capital letter to rewrite the sentences.**

(a) Where does Musa live

\_\_\_\_\_

(b) My daddy is a doctor

\_\_\_\_\_

(c) mary has a book.

\_\_\_\_\_

3. **Give the opposite of the underlined words.**

(a) Tom is a boy. \_\_\_\_\_

(b) She is a good girl. \_\_\_\_\_

(c) She shuts the door every day. \_\_\_\_\_

Friday

1. **Write the words correctly.**

(a) te\_\_che\_\_ (b) gi\_\_ \_\_

(c) ta\_\_l\_\_

2. **Rewrite the sentences as instructed in brackets.**

(a) The girl has a pen.

(Rewrite using: .....have.....)

\_\_\_\_\_

(b) These are pencils. (Rewrite and begin: This.....)



---

(c) The boy is reading a book.

(Rewrite and begin: He .....)

---

(d) She has eggs. (Rewrite and use: .....an.....)

---

(e) Mary is a girl. (Rewrite and begin: She.....)

---

(f) Ali has books. (Rewrite and use: .....a.....)

---

3. **Circle the different word.**

(a) chair, head, hand, hair

(b) bench, stool, chair, book

(c) pencil, pen, chalk, blackboard

(d) cow, goat, snake, sheep

## WEEK III

Monday

1. Write the picture number.

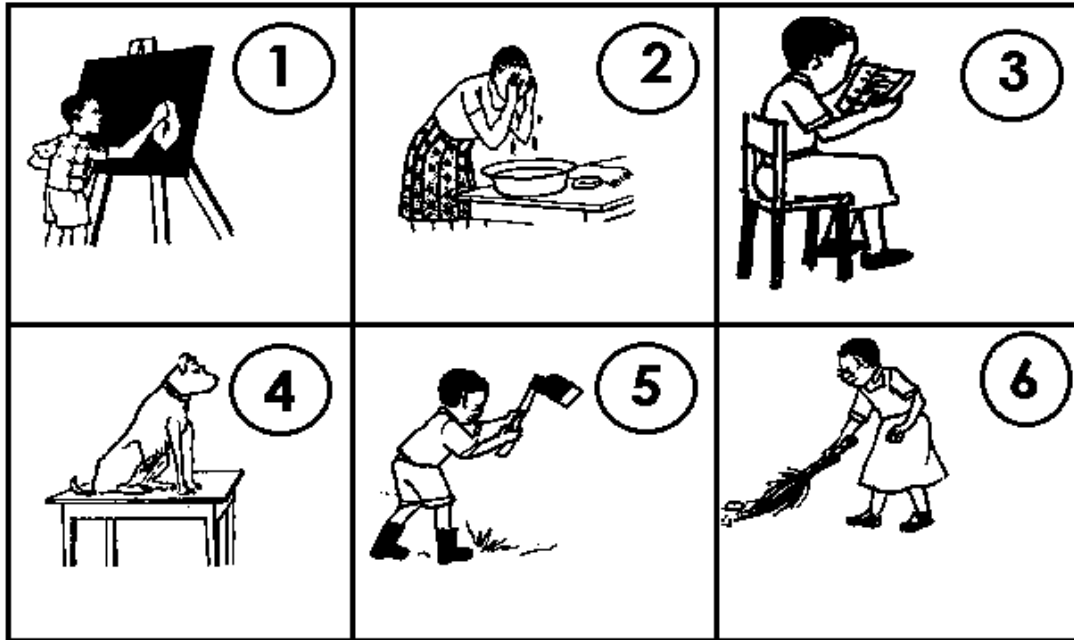

- (a) Tom is digging with a hoe. Picture number \_\_\_\_\_
- (b) She is reading a book. Picture number \_\_\_\_\_
- (c) The dog is on the table. Picture number \_\_\_\_\_
- (d) A girl is sweeping. Picture number. \_\_\_\_\_
- (e) She is washing her face. Picture number \_\_\_\_\_

2. Arrange the sentences in the correct order.

- (a) At the school gate, he greets his teachers.
- (b) Ali is a P. 1 boy.
- (c) He goes to his father's car.
- (d) Every morning, he puts on his uniform.

(e) His father drives him to school.

---

---

---

---

---

---

---

3. **Match the parts in the sentences correctly.**

(a) A teacher uses                      guards our homes.

(b) He is eating                         nine trees.

(c) Where does                         chalk to write.

(d) I can count                         Tom live?

(e) A dog                                 an apple.

Tuesday

1. **Use a correct word to fill the gaps.**

(a) Jane is reading \_\_\_\_\_ book.

(b) Mary \_\_\_\_\_ a big bag.

(c) The flowers are \_\_\_\_\_ the pot.

(d) Ali is eating \_\_\_\_\_ egg.

2. **Use the given words to fill the gaps in the story.**

( home , at, works , our , sick )

Miss Joan is \_\_\_\_\_school nurse. She lives \_\_\_\_\_  
Kibuye. She \_\_\_\_\_in the sick bay. She treats  
\_\_\_\_\_children. She gives them medicine. She  
then calls their parents to take them \_\_\_\_\_.

3. **Read the story and answer the questions.**

Mary is at Kira Primary School. She is in P.1.She lives at  
Katwe. Mary is five years old. Her father is Mr. Mutwe.  
He is a farmer. Mr. Mutwe has three sons and one  
daughter.

**Questions:**

(a) Who is the story about?

\_\_\_\_\_

(b) How old is she?

\_\_\_\_\_

(c) In which class is Mary?

\_\_\_\_\_

(d) What work does her father do?

\_\_\_\_\_

(e) How many children does Mr. Mutwe have?

\_\_\_\_\_

WEEK I

Monday

1. Name the given pictures.



\_\_\_\_\_



\_\_\_\_\_

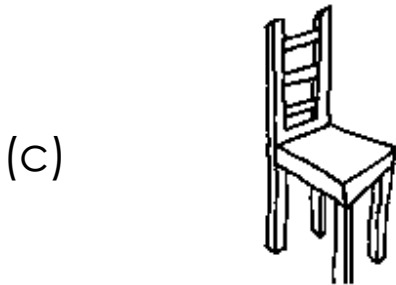

\_\_\_\_\_

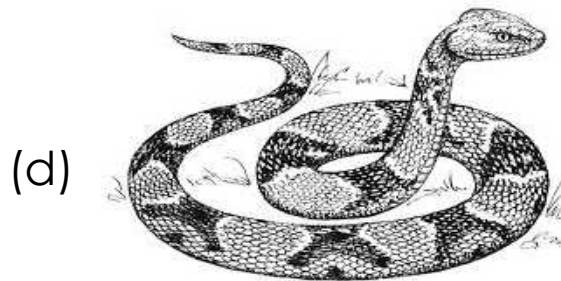

\_\_\_\_\_

2. Fill in the missing letters to form words.

(a) ch\_\_ \_\_k

(b) h\_\_u\_\_e

(c) f\_\_ \_\_we\_\_

(d) te\_\_c\_\_e\_\_

3(a) Copy the given letters correctly.

**s s s s s**

(b) Copy the give words correctly.

**snail snake school**

-----  
\_\_\_\_\_  
(c) Copy the given pattern correctly.



\_\_\_\_\_  
(d) Copy the given sentence correctly.

**Snails have shells.**

-----  
\_\_\_\_\_  
-----  
\_\_\_\_\_

Tuesday

1. **Use the given sounds to write words.**

(a) b: \_\_\_\_\_ (b) a: \_\_\_\_\_

(c) e: \_\_\_\_\_

2. **Complete the gaps correctly.**

(a) A cat eats \_\_\_\_\_.

(b) We use our \_\_\_\_\_ to walk.

(c) A cow has \_\_\_\_\_ legs.

3. **Read and draw pictures.**

(a) The ball is under the table.

(b) I can see three trees.

(c) A flower is in the tin.

(d) She has four cats.

Wednesday

1. **Join the letters to make four correct words.**

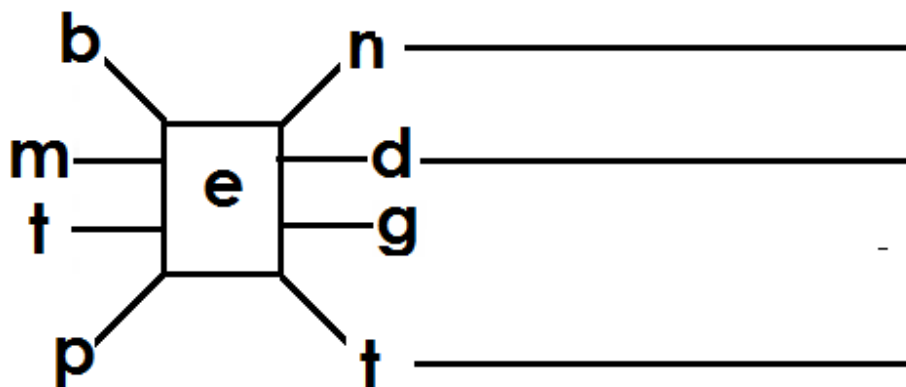

2. Write sentences about the picture.

(a)



(b)



(c)



3. Circle two words in the letter table and write them down.

|   |   |   |   |   |   |   |   |   |   |
|---|---|---|---|---|---|---|---|---|---|
| c | l | a | s | s | r | o | o | m | b |
| h | e | n | e | l | e | v | e | n | l |
| a | d | d | v | n | u | r | s | e | a |
| l | o | v | e | i | t | e | a | s | c |
| k | n | a | n | i | n | e | n | t | k |
| p | e | n | c | i | l | l | d | o | t |
| d | u | s | t | e | r | a | t | w | o |



(a) \_\_\_\_\_ (b) \_\_\_\_\_

(c) \_\_\_\_\_ (d) \_\_\_\_\_

Thursday

1. **Write four small words from the given word without changing the order of the letters.**

**teacher**

(a) \_\_\_\_\_ (b) \_\_\_\_\_

(c) \_\_\_\_\_ (d) \_\_\_\_\_

2. **Use the given letters to write two words.**

**t, a, m, e**

(a) \_\_\_\_\_ (b) \_\_\_\_\_

(a) \_\_\_\_\_ (b) \_\_\_\_\_

3. **Complete the word puzzle correctly.**

|   |  |   |
|---|--|---|
| m |  | t |
|   |  |   |
| t |  | n |

Friday

1. **Write Yes or No to fill the gaps.**

(a) A nurse treats sick children. \_\_\_\_\_

(b) A child has two eyes. \_\_\_\_\_

(c) Most children use earoplanes to come to school.

\_\_\_\_\_

(d) People have four hands on their bodies. \_\_\_\_\_

(e) We use a sponge to comb our hair. \_\_\_\_\_

2. **Write words of three letters from the word wheel.**

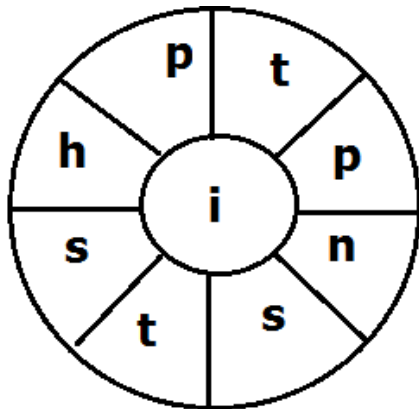

a. \_\_\_\_\_

b. \_\_\_\_\_

c. \_\_\_\_\_

3. **Use the correct word from the brackets to fill the gaps.**

(a) The \_\_\_\_\_ is in the sky. (son, sun)

(b) My father lives in a \_\_\_\_\_. (hut, hat)

(c) He has \_\_\_\_\_ water in the cup. (some, sum)

WEEK II

Monday

1. **Fill in the missing letters to form words.(2 marks each)**

|   |  |  |  |
|---|--|--|--|
| C |  |  |  |
| C |  |  |  |
| C |  |  |  |
| C |  |  |  |

2. **Write the**

1. **Write the given words correctly.**

(a) meho: \_\_\_\_\_ (b) rahtef: \_\_\_\_\_

(c) rutasctb: \_\_\_\_\_ (d) ader: \_\_\_\_\_

3. **Name the pictures given below.**



(a)

\_\_\_\_\_



(b)

\_\_\_\_\_



(c)

\_\_\_\_\_

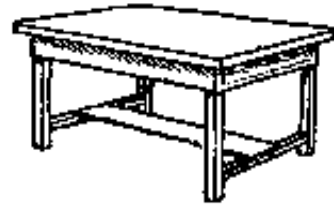

(d)

\_\_\_\_\_

Tuesday

1. **Write a small word from each of the given words.**

(a) weather: \_\_\_\_\_ (b) butterfly: \_\_\_\_\_

(c) heat : \_\_\_\_\_

2. **Write the given words correctly.**

(a) senur: \_\_\_\_\_ (b) lcsas: \_\_\_\_\_

(c) apso \_\_\_\_\_ (d) aksen: \_\_\_\_\_

3(a) Copy the letters correctly.

Nn Nn Nn Nn

(b) Copy the words correctly.

nap nest pin star

(c) Copy the pattern correctly.

~~~~~

(d) Copy the sentence correctly.

**A bird has a big nest.**

Wednesday

1. **Write words using the given sounds.**

(a) i: \_\_\_\_\_ (b) t: \_\_\_\_\_

(c) ea: \_\_\_\_\_ (d) p: \_\_\_\_\_

2. **Use a correct word to fill the gaps.**

(a) A cat is an \_\_\_\_\_.

(b) Two plus \_\_\_\_\_ equals three.

(c) Teachers use chalk to \_\_\_\_\_.

(d) We eat \_\_\_\_\_ at lunch time.

(e) People use eyes to \_\_\_\_\_ books

3. **Write sentences about the pictures.**

(a)



\_\_\_\_\_

(b)



(c)



(d)



Thursday

1. **Write words using the given sounds or spellings.**

(1 mark each)

(a) ch: \_\_\_\_\_ (b) a: \_\_\_\_\_

(c) ea: \_\_\_\_\_ (d) cl: \_\_\_\_\_

2. **Complete the word puzzle.**

|   |  |  |   |
|---|--|--|---|
| m |  |  | t |
|   |  |  |   |
|   |  |  |   |
| n |  |  | e |

3. **Read and draw pictures**

(a) The ball is in a basket.

(b) I can see four cats.

(c) The man is cutting a tree.

(d) The girl is reading a book.

Friday

1. **Write three small words from the given word without changing the order of the letters.**

**wheat**

(a) \_\_\_\_\_ (b) \_\_\_\_\_

(c) \_\_\_\_\_

2. **Use a correct word to fill the gaps.**

- (a) Cows eat \_\_\_\_\_.
- (b) His father \_\_\_\_\_ a big car.
- (c) Mary and Jane \_\_\_\_\_ playing netball.
- (d) She uses a pencil to \_\_\_\_\_ in her book.
- (e) People use \_\_\_\_\_ to walk.

3. **Write 'Yes' or 'No' to fill the gaps.**

- (a) Most children use earoplanes to come to school.  
\_\_\_\_\_
- (b) People have four hands on their bodies. \_\_\_\_\_
- (c) We use a sponge to comb our hair. \_\_\_\_\_
- (d) Fish live in water. \_\_\_\_\_
- (e) We use eyes to see. \_\_\_\_\_

WEEK 3

Monday

1. **Use a correct word to fill the gaps.**

- (a) A cat is an \_\_\_\_\_.
- (b) Two plus \_\_\_\_\_ equals three.
- (c) Teachers use chalk to \_\_\_\_\_.
- (d) We eat \_\_\_\_\_ at lunch time.
- (e) People use eyes to \_\_\_\_\_ books.



2. There are four names of people we find at school hidden in the letters. Circle them and write them

|   |   |   |   |   |   |   |   |   |   |   |
|---|---|---|---|---|---|---|---|---|---|---|
| h | e | a | d | t | e | a | c | h | e | r |
| c | i | r | i | r | a | n | o | t | a | t |
| l | l | t | r | o | t | d | o | o | r | b |
| e | b | l | e | t | e | n | k | l | c | u |
| a | r | t | c | p | l | u | s | i | r | r |
| n | a | n | t | e | a | c | h | e | r | s |
| e | r | c | o | a | s | a | e | a | e | a |
| r | n | u | r | s | e | r | e | t | a | r |
| g | a | t | e | k | e | e | p | e | r | u |

(2 marks each)

- (a) \_\_\_\_\_ (b) \_\_\_\_\_  
 (c) \_\_\_\_\_ (d) \_\_\_\_\_

3. Form a new word by replacing the first letter in each word. (2 marks each)

- (a) cell: \_\_\_\_\_ (b) sail: \_\_\_\_\_  
 (c) most: \_\_\_\_\_ (d) seat: \_\_\_\_\_

Tuesday

1. Name the pictures given below.



\_\_\_\_\_



\_\_\_\_\_

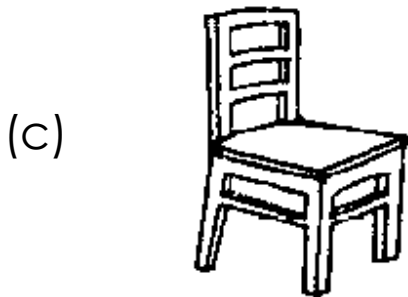

\_\_\_\_\_



\_\_\_\_\_

2. Choose the correct word from brackets to fill the gaps.

(a) The \_\_\_\_\_ child has gone to the nurse.

(thick, sick)

(b) Monday is one of the days of the \_\_\_\_\_.

(wick, week, weak)

(c) That \_\_\_\_\_ is eating a rat. (cut, cart, cat)

(d) The \_\_\_\_\_ is flying over a tree.

(bird, bud, bad)

(e) He \_\_\_\_\_ football in the school team.  
(plays, prays.)

3. **Use the letters given below to write 6 different words.**

**l, p, a, n, t**                      **2 marks each**

(a) \_\_\_\_\_ (b) \_\_\_\_\_

(c) \_\_\_\_\_ (d) \_\_\_\_\_

(e) \_\_\_\_\_

Wednesday

16. **Use all the letters in the given word to write a new word.**

(a) fan: \_\_\_\_\_ (b) net: \_\_\_\_\_

(c) \_\_\_\_\_ (d) \_\_\_\_\_

17. Write words of four letters from the word wheel below.

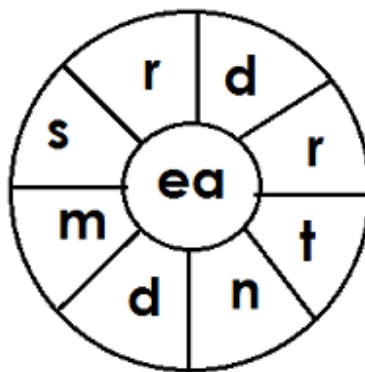

(a) \_\_\_\_\_ (b) \_\_\_\_\_

18. **Read and give the correct answer.**

(a) I am white. I flow like water. I come from a cow. You drink me. Who am I?

---

(b) I am oval. I am some time brown. I am sometimes white. I come from a hen. You have to break me before you eat me. Who am I?

---

(c) I am a rectangle. I am black. I am found in your classrooms. Teachers write on me. Who am I?

---

(d) I am made of wood. I have four legs. You sit on me. Who am I?

---

**Kabojja Junior School**  
**P. 1 TERM I HOLIDAY WORK**  
**Literacy II**  
**WEEK I**

**MONDAY**

1. Write down the name of our school.

---

2. Give one use of water in a school.

---

3. Write down one way children come to school.

---

4. Name the animal in the picture.



---

5. Name the things you see on your way to school.

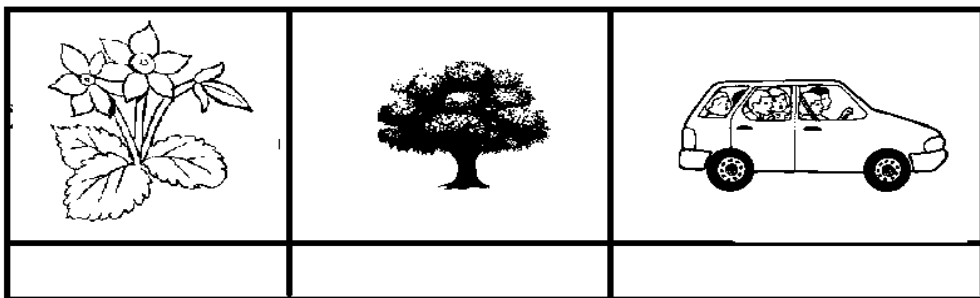

## Tuesday

1. What do children use to write in their books?

---

2. Give one thing (activity) children do at school.

---

3. Draw a picture of tree in the space below.

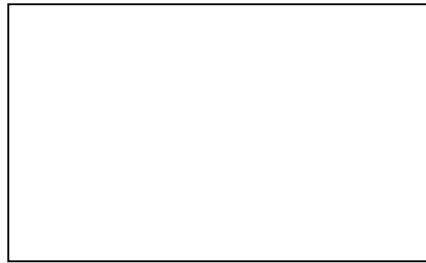

4. Write one thing children use to play at school.

---

5. Name three animals found in a home.

(a) \_\_\_\_\_ (b) \_\_\_\_\_

(c) \_\_\_\_\_

## Wednesday

1. Who is the head of a school?

---

2. Write any one activity children do in class.

---

3. Name one thing found in the dining hall.

---

4. Mention the body part we use to walk.

---

5. **Match correctly.**

(a) teacher                                          medicine

(b) nurse                                                broom

(c) cleaner                                             chalk

**Thursday**

1. Write one thing we use to keep the classroom clean.

---

2. Who treats sick children in a school?

---

3. Name the place where children go to learn.

---

4. Write the dangerous thing shown below.



---

5. Draw these things we use at home.

|              |              |             |
|--------------|--------------|-------------|
|              |              |             |
| <b>chair</b> | <b>house</b> | <b>cups</b> |

**Friday**

1. Duster is to blackboard as rubber is to \_\_\_\_\_.
2. Give the use of money in a school.

\_\_\_\_\_

3. What is the work of teacher in a school?

\_\_\_\_\_

4. Write the name of our school.

\_\_\_\_\_

5(a) Write down any two parts of the body found on the head.

- (I) \_\_\_\_\_ (II) \_\_\_\_\_

(b) Write one way of looking after our hair.

\_\_\_\_\_



## WEEK II

### Monday

1. What do teachers use to write on the blackboard?

---

2. Name one item children use in a classroom.

---

3. Write down one of water at school.

---

### Use the picture to answer questions 4 and 5.



4. Name the part of the body in the picture above.

---

5. How is the above body part useful to man?

---

6. Which group of people use brooms in a school?

---

7. Write any one means children use to come to school.

---

## **Tuesday**

1. Name one place where a school gets water.

---

2. What is the work of a nurse in a school?

---

3. Give one animal found in our homes.

---

4. State one use of trees in a school compound.

---

5. Name the places at school where these activities take place:

(b) teaching children: \_\_\_\_\_

(b) treating sick children: \_\_\_\_\_

(c) preparing food for children: \_\_\_\_\_

## **Wednesday**

1. Draw a fork in the space given below.

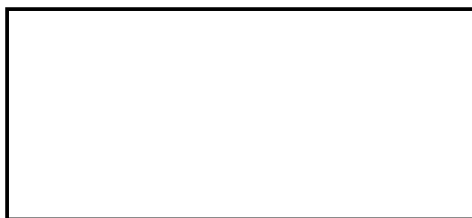

2. Name the place in a school children get books for reading.

---

3. Give one use of a house to people.

---

4. Mention one use of money to school.

---

5. Name these things we use in a home.

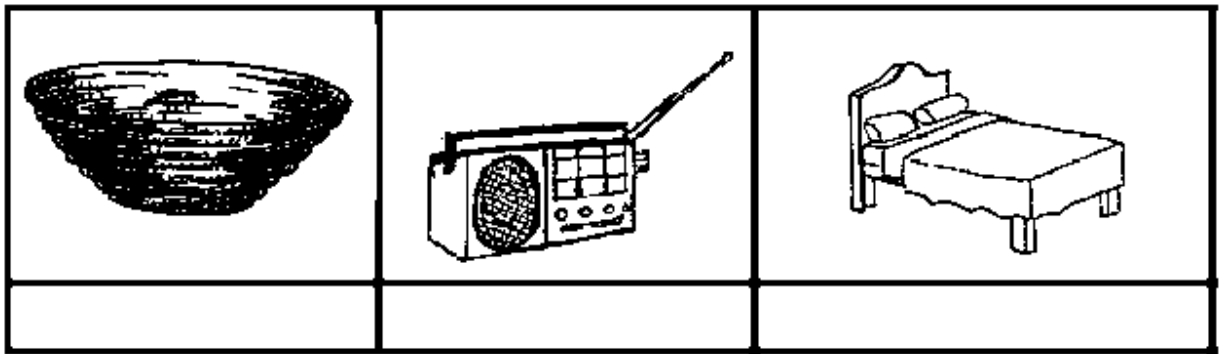

### Thursday

1. Name one activity children do at home.

---

2. Mention one thing children play with at school.

---

3. Give the importance of a garage in a house.

---

4. Which group children at school put on dresses?

---

5(a) Give one duty of a father to a family.

---

(b) Mention one way mothers help the children in a home.

---

(c) Write one source of food to a family.

---

### **Friday**

1. Name the body part people use for smelling.

---

2. Give one use of a pot in a home.

---

3. Mention one way we keep our bodies clean.

---

4. Write down one item teachers use in the classroom.

---

5(a) Name the parts of the body we use for:

(i) Hearing: \_\_\_\_\_

(ii) Smelling: \_\_\_\_\_

(b) How is a tongue useful to animals?

---

## WEEK III

### Monday

1. Name one thing found in a school compound.

---

2. What is the duty of a nurse in a school?

---

3. Give one use of a hen in a home.

---

4. Name one thing children play with at school.

---

5(a) Name these things we use in a classroom.

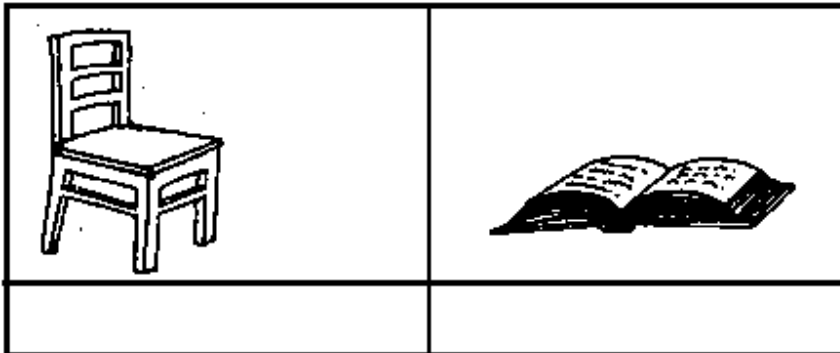

(b) Give one use of a duster to teacher.

---

### Tuesday

1. Who is the head of a family?

---

2. Mention one dangerous thing found in a home.

---

3. Teacher is to classroom as nurse is to \_\_\_\_\_.

4. Give one use of water in a school.

---

5(a) Give two activities children do at school.

(i) \_\_\_\_\_

(ii) \_\_\_\_\_

(b) Mention one way balls are useful to children at school.

---

### **Wednesday**

1. Write down any one activity children do in the dining hall.

---

**Use the picture to answer questions 2 and 3.**



2. Name the item in the picture above.

---

3. Give the use of the item above in a home.

---

4. Write one activity we do using textbooks.

---

5. **Match correctly.**

soap

cutting finger nails

comb

bathing

razorblade

combing

**Thursday**

1. Give one duty of a gatekeeper.

---

2. Why do children come to school?

---

3. Draw a picture of blackboard in the space given below.

4. Name one animal that guards our homes.

---

5(a) Which animal gives us milk in our homes?

---

(b) Give one way trees are useful in our homes.

---

(c) Which food do goats eat?

---

**Friday**

1. Give one way people use brooms at school.

---

2. Nurse is to a sickbay as \_\_\_\_\_ is to a classroom.

3. Give one activity children do at school.

---

4. Name the picture drawn below.

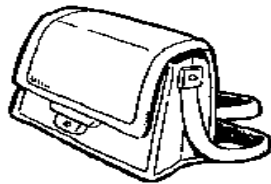

---

5. Give one way the following places are useful to a school:

(a) market

---

(b) bank

---

(c) well

---





# Kabojja Junior School

## P. 1 Term I Holiday Work 2020

### Mathematics

#### WEEK I

#### Monday

1. Count and write:



2. Write the missing numbers: 3, 4, \_\_\_\_\_, 6, 7, \_\_\_\_\_.

3. Name the shape shown below:



\_\_\_\_\_

4. Add:  $3 + 2 =$  \_\_\_\_\_

5. Write 11 in words. \_\_\_\_\_

6. Take away (subtract):

(a)  $7 - 7 =$  \_\_\_\_\_

(b)  $6 - 0 =$  \_\_\_\_\_

(c) 
$$\begin{array}{r} 9 \\ - 5 \\ \hline \\ \hline \end{array}$$

(d) Ann has 5 sweets. She gives 3 sweets to Mary. How many sweets does she remain with?

---

### Tuesday

1. What number comes before 9?
2. Arrange from smallest to the biggest:  
9, 3, 6, 1: \_\_\_\_\_
3. Write 13 in words.
4. Take away:  $6 - 6 =$  \_\_\_\_\_
5. Tell the time on the clock face.



It is \_\_\_\_\_ o'clock.

6. **Match correctly:**

(a) 5 eleven

(b) 15 three

(c) 3 five

(d) 11 fifteen

**Wednesday**

1. What number comes after 6?

2. How many groups of 2 can you count?

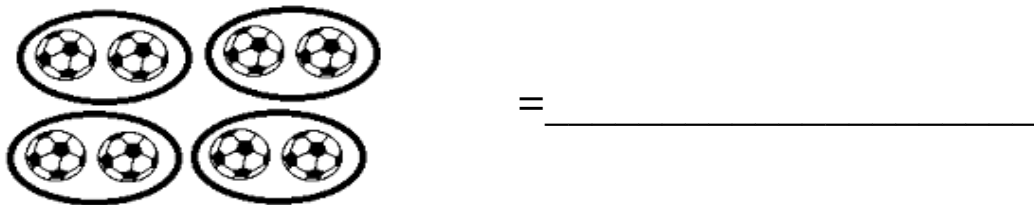

3. Draw a rectangle in the space below.

14. Cross out to make them 5.



5. Draw to make them 7.

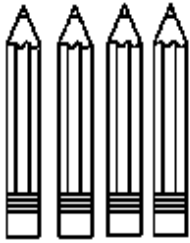

6(a) Name the shapes drawn below.

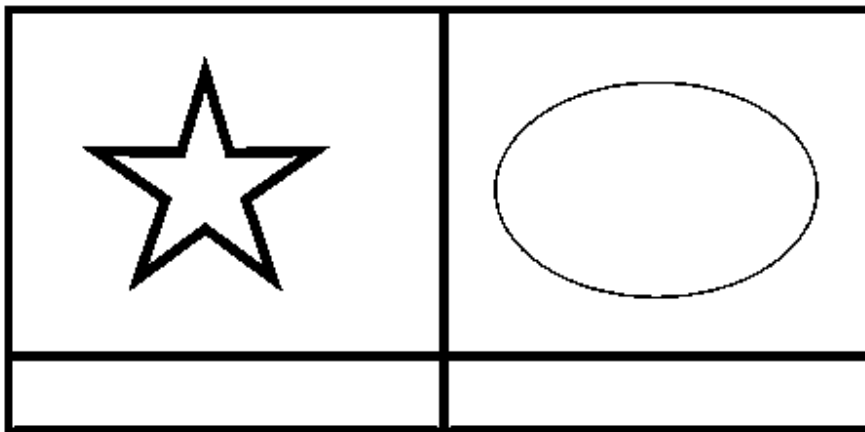

(b) Draw the shapes named below.



### Thursday

1. Write the number between 7 and 9. \_\_\_\_\_

2. Circle the smaller number.

7 , 9

3. Multiply:  $4 \times 2 =$  \_\_\_\_\_

4. Draw 7 cats.

5. What is 9 take away 2?

6. Add:

(a)  $1 + 3 + 2 =$  \_\_\_\_\_      (b)  $6 + 3 =$  \_\_\_\_\_

(c) 
$$\begin{array}{r} 5 \\ + 0 \\ \hline \hline \end{array}$$

(d) Musa has 4 apples . He gets 4 more apples. How many apples does he have altogether?

---

## Friday

1. Write the number between 19 and 21.

2. Multiply:  $3 \times 2 = \underline{\hspace{2cm}}$

3. Count and write the number.

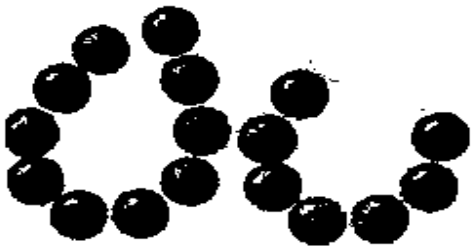

---

4. Draw and make them 9.



5. What is 3 more than 4?

6. **Match correctly:**

- |        |        |
|--------|--------|
| (a) 11 | five   |
| (b) 0  | eight  |
| (c) 5  | eleven |
| (d) 8  | zero   |

## WEEK II

### Monday

1. Multiply:  $2 \times 2 =$  \_\_\_\_\_
2. Write the missing numbers: 12, 11, 10, \_\_\_\_\_, 8, \_\_\_\_\_.
3. What number comes between 15 and 13?
4. Write 19 in words. \_\_\_\_\_
5. Subtract:  $7 - 7 =$  \_\_\_\_\_
6. **How many can you count?**

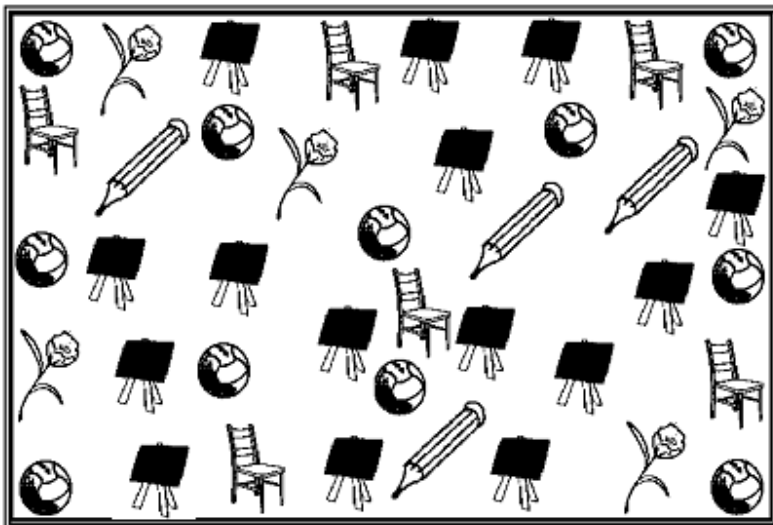



(a) How many  can you count? \_\_\_\_\_

(b) How many  can you count? \_\_\_\_\_

(c) How many  can you count? \_\_\_\_\_

(d) How many  can you count? \_\_\_\_\_

6. Name the shape drawn below.

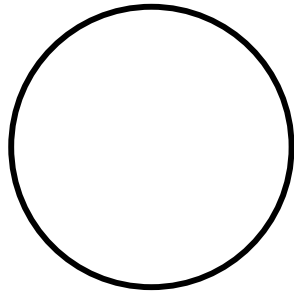

\_\_\_\_\_

## **Tuesday**

1. Draw thirteen balls in the space below.

2. Arrange from the biggest to the smallest number.

11, 7, 15, 9: \_\_\_\_\_

3. Add:  $5 + 3 =$  \_\_\_\_\_

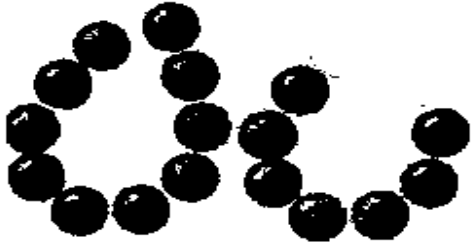

4. What number comes before 25?

5. Count and write.

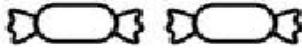

\_\_\_\_\_

6. **The graph shows the number of sweets each of the four children has.**

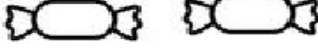
| Name | Number of sweets                                                                    |
|------|-------------------------------------------------------------------------------------|
| Ali  |   |
| Juma |  |
| Jane |  |
| Ann  |  |

(a) Who have the same number of sweets?

\_\_\_\_\_

(b) How many sweets does Ali have?

\_\_\_\_\_

(c) Who has one sweet?

\_\_\_\_\_

(d) How many sweets do Jane and Ann have altogether?

\_\_\_\_\_

## Wednesday

1. What is 3 less than 7?
2. Which bottle holds more water?

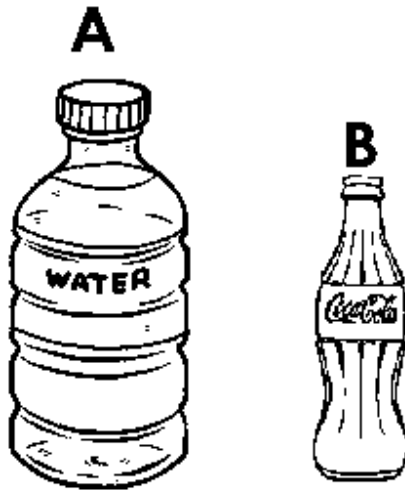

3. Cross out and make them 5.



4. Draw a set 4 chairs.

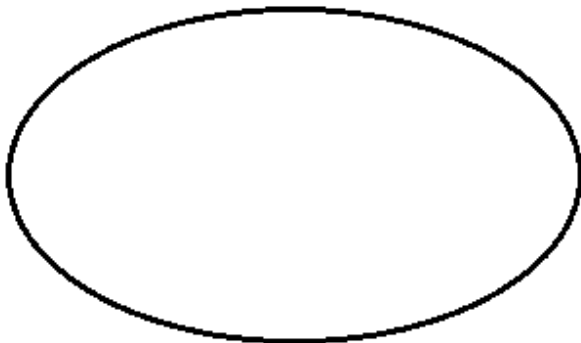

6. **Add:**

(a)  $2 + 0 + 5 = \underline{\quad}$

(b) 
$$\begin{array}{r} 3 \\ + 6 \\ \hline \end{array}$$

(c) 
$$\begin{array}{r} 1 \quad 1 \\ + \quad 8 \\ \hline \end{array}$$

(d) There are 12 pencils in a tin. A boy puts 5 more pencils. How many pencils are in the tin altogether?

---

### **Thursday**

1. What is 2 more than 3?

2. Tell the time on the clock face below.



3. Draw cups to make them 7.



4. Join set A with set B.

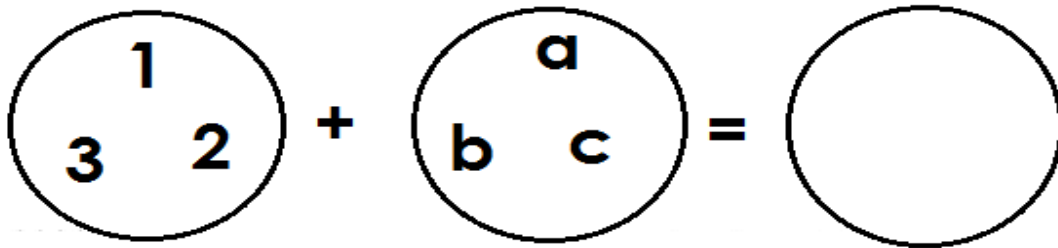

5. Which tree is taller?

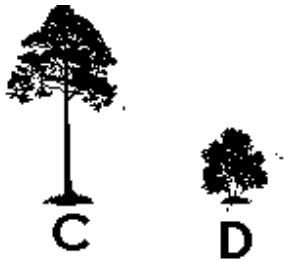

6(a) Name the shapes drawn below.

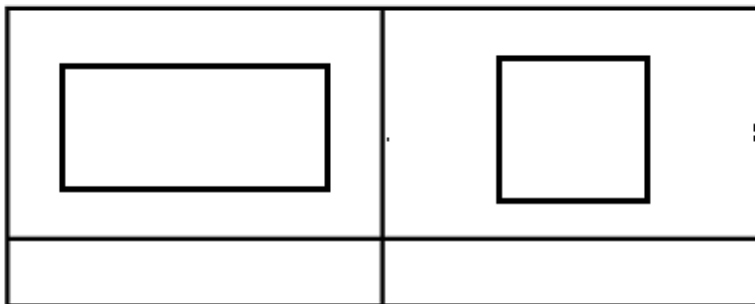

(b) Draw the shapes named below.



## Friday

1. Add:  $2 + 1 = \underline{\quad}$
2. Fill in the missing numbers: 3, 4, 5,  $\underline{\quad}$ ,  $\underline{\quad}$ , 8.
3. Write 7 in words.  $\underline{\hspace{10em}}$
4. Name the given shape.

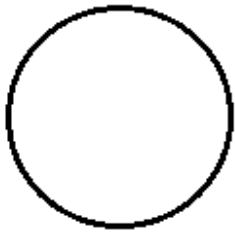

$\underline{\hspace{10em}}$

5. What number comes after 5?  $\underline{\hspace{10em}}$

6. **Fill in the missing numbers.**

(a)  $\underline{\quad} + \underline{\quad} = 5$

(b)  $\underline{\quad} - \underline{\quad} = 4$

(c)  $\underline{\quad} + \underline{\quad} = 7$

(d)  $\underline{\quad} - \underline{\quad} = 0$

# WEEK III

## Monday

1. Count and write the number.



2. Take away:  $5 - 3 =$  \_\_\_\_\_

3. Write 7 in words: \_\_\_\_\_

4. What is the time on the clock face below?



\_\_\_\_\_

5. How many groups of 2 can you see?

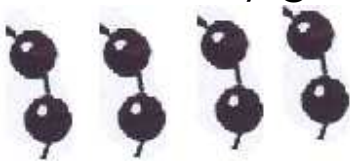

\_\_\_\_\_

6. Use set A and set B to answer the questions that follow.

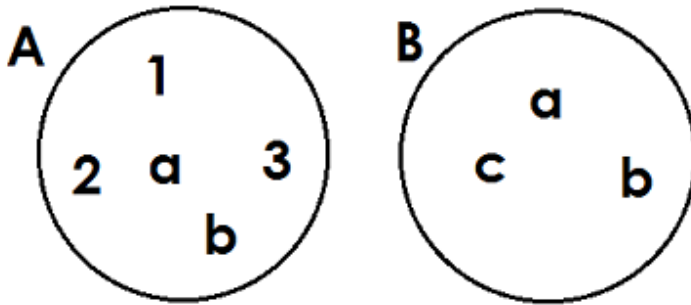

(a) Name set B.

---

(b) How many members are in set A?

---

(c) Which set has more members?

---

(d) Separate set B from set A.

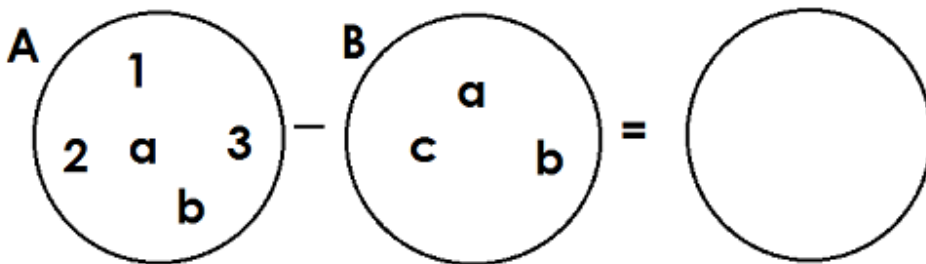

## Tuesday

1. Arrange from smallest to biggest: 2, 0, 6, 1

---



2. Draw a triangle in the space below.

3. Write ten in figures. \_\_\_\_\_

4. Cross out to make them 5.



5. Draw to make them 8.



6. Write "Yes" or "No" .

(a)  This is a circle. \_\_\_\_\_

(b) Two plus three equals five. \_\_\_\_\_

(c) Seven take away zero equals nine. \_\_\_\_\_

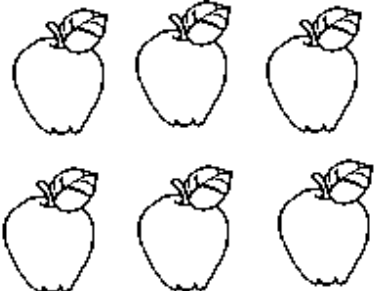
(d)  There are seven apples. \_\_\_\_\_

## Wednesday

1. What number comes before 9? \_\_\_\_\_
2. Circle the bigger number: 8 , 5
3. Multiply:  $3 \times 2 =$  \_\_\_\_\_
4. Arrange from biggest to smallest: 1, 10, 3, 7  
\_\_\_\_\_
5. What is two plus five? \_\_\_\_\_

6. **Add correctly:**

(a)  $2 + 7 =$  \_\_\_\_\_ (b)  $1 + 3 =$  \_\_\_\_\_

(c) 
$$\begin{array}{r} 5 \\ + 4 \\ \hline \hline \end{array}$$

- (d) Jane has 3 books. She gets 5 more books. How many books does she have altogether?
- \_\_\_\_\_

## Thursday

1. Subtract:  $8 - 5 =$  \_\_\_\_\_
2. Write 13 in words.
3. What number comes after 16?
4. Add:  $7 + 2 =$  \_\_\_\_\_
5. Write the missing number: 12, 13, 14, \_\_\_\_\_, 16, 17.

6. **Subtract (Take away):**

- (a)  $9 - 0 =$  \_\_\_\_\_      (b)  $3 - 3 =$  \_\_\_\_\_      (c)

$$\begin{array}{r} 9 \\ - 4 \\ \hline \\ \hline \end{array}$$

- (d) John has 8 balls. He gives 4 balls to Ali. How many balls does John remain with?

---

## Friday

1. Draw six girls in the space below.

2. Arrange the numbers from smallest to biggest.

17, 15, 13, 11, 19: \_\_\_\_\_

3. Cross out and make them 7.



4. Which tree is shorter?



5. Name the set given below.



\_\_\_\_\_

6. **Fill in the missing numbers.**

(a) \_\_\_\_\_ + \_\_\_\_\_ = 4      (b) \_\_\_\_\_ - \_\_\_\_\_ = 3

(c) \_\_\_\_\_ x \_\_\_\_\_ = 8      (d) \_\_\_\_\_ - 0 = 5