



Ministry of Education  
and Sports

# HOME-STUDY LEARNING

PRIMARY  
5

# MATHEMATICS

August 2020



Save the Children





Published 2020

This material has been developed as a home-study intervention for schools during the lockdown caused by the COVID-19 pandemic to support continuity of learning.

Therefore, this material is restricted from being reproduced for any commercial gains.

National Curriculum Development Centre  
P.O. Box 7002,  
Kampala- Uganda  
[www.ncdc.go.ug](http://www.ncdc.go.ug)

## FOREWORD

Following the Outbreak of the CoVID-19 Pandemic, Government of Uganda closed all schools and other educational institutions to minimize the spread of the coronavirus. This has affected more than 36,314 primary schools, 3129 secondary schools, 430,778 teachers and 12,777,390 learners.

The COVID-19 outbreak and subsequent closure of all has had drastically impacted on learning especially curriculum coverage, loss of interest in education and learner readiness in case schools open. This could result in massive rates of learner dropouts due to unwanted pregnancies and lack of school fees among others.

To mitigate the impact of the pandemic on the education system in Uganda, the Ministry of Education and Sports (MoES) constituted a Sector Response Taskforce (SRT) to strengthen the sector's preparedness and response measures. The SRT and National Curriculum Development Centre developed print Home- Study Materials, radio and television scripts for some selected subjects for all learners from Pre-Primary to Advanced level. The materials will enhance continued learning and learning for progression during this period of the lockdown, and will still be relevant when schools resume.

The materials focused on critical competences in all subjects in the curricula to enable the learners to achieve without the teachers' guidance. Therefore effort should be made for all learners to access and use these materials during the lockdown. Similarly, teachers are advised to get these materials in order to plan appropriately for further learning when schools resume, while parents/guardians need to ensure that their children access copies of these materials and use them appropriately.

I recognise the effort of National Curriculum Development Centre in responding to this emergency through appropriate guidance and the timely development of these home study materials. I recommend them for use by all learners during the lockdown.



**Alex Kakooza**

**Permanent Secretary**

**Ministry of EDUCATION AND SPORTS**

## ACKNOWLEDGEMENTS

National Curriculum Development Centre (NCDC) would like to express its appreciation to all those who worked tirelessly towards the production of home-study materials for Pre-Primary, Primary and Secondary Levels of Education during the COVID-19 lockdown in Uganda.

The Centre appreciates the contribution from all those who guided the development of these materials to make sure they are of quality; Development partners - SESIL, Save the Children and UNICEF; all the Panel members of the various subjects; sister institutions - UNEB and DES for their valuable contributions.

NCDC takes the responsibility for any shortcomings that might be identified in this publication and welcomes suggestions for improvement. The comments and suggestions may be communicated to NCDC through P.O. Box 7002 Kampala or email [admin@ncdc.go.ug](mailto:admin@ncdc.go.ug) or by visiting our website at <http://ncdc.go.ug/node/13>.



**Grace K. Baguma**  
Director,  
National Curriculum Development Centre

## **ABOUT THIS BOOKLET**

Dear learner, welcome to this home-study material which has been prepared for you. The material covers content for term 1, II and III.

The content covered has been carefully written covering the different topics in the syllabus. This is an addition to what you had learnt before schools were closed due to outbreak of COVID-19. The content is arranged using simple steps for your understanding. The activities provided in each topic are organised in such a way that they will enable you to relate with your local environment.

The content is organised into lessons. Each lesson has activities and summary notes that help you to understand the concepts. Some lessons have projects that you need to carry out at home during this period. You are encouraged to work individually as you do the practical and interactive activities.

Feel free to try out all the activities in this material.

**Enjoy learning**



## Term One

### Topic: Operations on whole numbers

#### Lesson 1: Multiplication of 3 digit numbers by two digit numbers.

##### In this lesson, you will:

- Multiply 3 digit numbers by two digit numbers.
- Solve word problems involving multiplication.

##### You will need:

- Counters like sticks and bottle tops.
- Multiplication table found at the back of the exercise book.
- An exercise book and a pen.

##### Introduction:

In primary four, you learnt how to multiply **3 digit number** by one-digit number. This is going to guide you greatly while multiplying **3 digit numbers** by 2-digit numbers.

It is helpful to know multiplication tables up to 12 because you can use them to multiply large numbers. You can also use counters when you get stuck.

Multiplication of whole numbers will help you when you are doing business as you grow up.

##### Step 1

##### Activity

You can use the multiplication tables when you get stuck.

- Work out:  
 $120 \times 4$
- Arrange the numbers vertically.  

$$\begin{array}{r} 120 \\ \times 4 \\ \hline 480 \end{array}$$
- Multiply by Ones, Tens and Hundreds.
- $4 \times 0 = 0$   
 $4 \times 20 = 80$   
 $4 \times 100 = 400$
- Now add the values.  
 $0 + 80 + 400 = 480$

So  $120 \times 4 = 480$

**Step 2**

**Look at this example**

**Example 1**

Work out:  $234 \times 12$

You are going to multiply by the values of each digit in 12.

The value of 2 is 2 and the value of 1 is 10.

This means  $(234 \times 2) + (234 \times 10)$

$$\begin{array}{r} 234 \times 2 = \quad 468 \\ 234 \times 10 = \quad + 2340 \\ \hline \quad \quad 2808 \end{array}$$

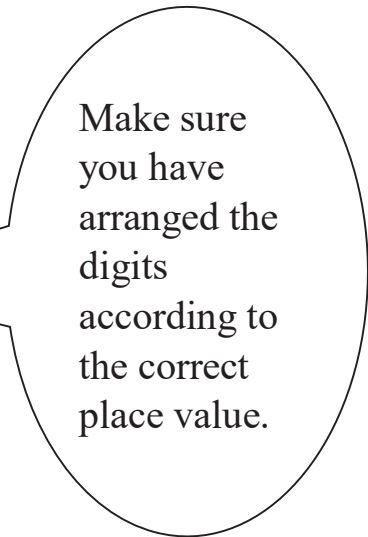

**Example 2**

Find the product of 124 and 23

The word product means the answer you get after multiplication.

This can be done using expanded form.

Method 1

This means  $(124 \times 3) + (124 \times 20)$

$$\begin{array}{r} (100 \times 3) + (20 \times 3) + (4 \times 3) = 300 + 60 + 12 = \quad 372 \\ (100 \times 20) + (20 \times 20) + (4 \times 20) = 2000 + 400 + 80 = \quad + 2480 \\ \hline \quad \quad 2852 \end{array}$$

Method 2

$$\begin{array}{r} \quad \quad 124 \\ \quad \quad \times 23 \\ \hline (124 \times 3) = \quad 372 \\ (124 \times 20) = \quad + 2480 \\ \hline \quad \quad 2852 \end{array}$$

**Exercise**

Now do the exercise below in your exercise book.

Work out:

1)  $121$

2)  $413$

$\times 13$

$\times 11$

3)  $245$

4) Find the product of 627 and 42.

$\times 17$

5) There are 245 rooms. Each room has 24 chairs. How many chairs are there altogether?

6) In a box there are 523 books. How many books are there in 24 boxes?



## Lesson 2: Multiplication of 4 digit numbers by 2 digit numbers.

**In this lesson, you will:**

- Multiply 4 digit numbers by 2 digit numbers.
- Solve word problems involving multiplication.

**You will need:**

- Counters
- Multiplication table found at the back of the book.
- An exercise book and a pen.

**Introduction:**

In the previous lesson, you learnt how to multiply 3 digit numbers by 2 digit numbers. Remember to multiply correctly and to observe the correct place value of digits while adding. In this lesson, you are going to learn how to multiply 4 digit numbers by 2 digit numbers.

### Step 1

#### Activity

- Collect many sticks/ straws.
- Make 15 bundles of 25 sticks each.
- How many sticks have you counted **altogether**?
- Write a multiplication sentence for the above activity.

### Step 2

Now study these examples.

#### Example 1

Work out:  $2031 \times 15$

$$\begin{array}{r} 2031 \\ \times 15 \\ \hline \end{array}$$

#### Method 1

This means  $(2031 \times 5) + (2031 \times 10)$

$$(2000 \times 5) + (30 \times 5) + (1 \times 5) = 10000 + 150 + 5 = 10155$$

$$(2000 \times 10) + (30 \times 10) + (1 \times 10) = 20000 + 300 + 10 = 20310$$

$$\underline{30465}$$

- First multiply each value by 5
- Then, multiply each value by 10.
- Add the values together.

#### Method 2

$$\begin{array}{r} 1 \\ 2031 \\ \times 15 \\ \hline \end{array}$$

$(2031 \times 5) = 10155$

you are using  
table 5 and table  
10

$$(2031 \times 10) = + \begin{array}{r} \underline{20,310} \\ \underline{30,465} \end{array}$$

**Example 2**

The government gave out face masks to 23 health centres. If each health centre got 3147 face masks. How many face masks did government give out altogether?

(3147 × 23) masks

Method 1

This means (3147 × 3) + (3147 × 20)

This can be expanded.

$$(3000 \times 3) + (100 \times 3) + (40 \times 3) + (7 \times 3) = 9000 + 300 + 120 + 21 = 9441$$

$$(3000 \times 20) + (100 \times 20) + (40 \times 20) + (7 \times 20) = 6000 + 2000 + 800 + 140 = + \underline{62940}$$

$$\underline{72381}$$

Therefore, the government gave out 72381 face masks.

Method 2

$$\begin{array}{r} 3147 \\ \times 23 \\ \hline (3147 \times 3) = 9441 \\ (3147 \times 20) = + \underline{62,940} \\ \hline \underline{72,381} \text{ face masks} \end{array}$$

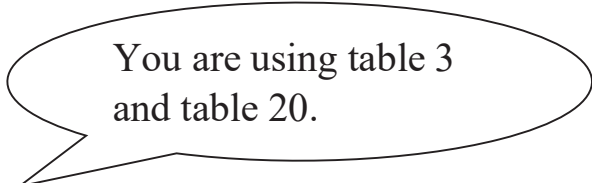

**Exercise**

Work out:

1.  $\begin{array}{r} 3419 \\ \times 23 \\ \hline \end{array}$

3.  $\begin{array}{r} 4262 \\ \times 19 \\ \hline \end{array}$

2.  $\begin{array}{r} 1263 \\ \times 32 \\ \hline \end{array}$

4.  $\begin{array}{r} 2416 \\ \times 15 \\ \hline \end{array}$

5. What is the product of 1,723 and 15?
6. Multiply 3,419 by 23.
7. A factory produces 2,479 bottles of sanitizers every day. How many bottles does the factory produce in 31 days?

**Lesson 3: Dividing by a two-digit number without a remainder.**

**In this lesson, you will:**

- Divide numbers by a 2-digit number without a remainder.
- Solve word problem involving division.

**You will need:**

- Counters.
- An exercise book and a pen.
- Multiplication table at the back of your exercise book.

**Introduction:**

You already learnt, multiplication and division are related.

You actually noticed that ‘multiplication tables’ are very helpful in division.

Remember words like: **divide**, **divisor**, **dividend**, and **quotient**.

**Step 1****Activity**

- Count 50 sticks.
  - Make 10 equal groups of using these sticks.
  - How many sticks are in each group?
  - a) Now divide 50 by 10.
  - b) Also divide 50 by 5.
- Compare the divisors. You will notice that the answer in **a** when multiplied by 10 gives 50 and the answer in **b** when multiplied by 5 gives 50.

**Remember: -**

- A **dividend** is the number being divided by another number.
- A **divisor** is the number that is divided by.
- A **quotient** is the answer after dividing two numbers.

**Step 2****Study the examples below****Example 1**

Divide 612 by 18

In other words, we take 612 and share it with 18 equal groups.

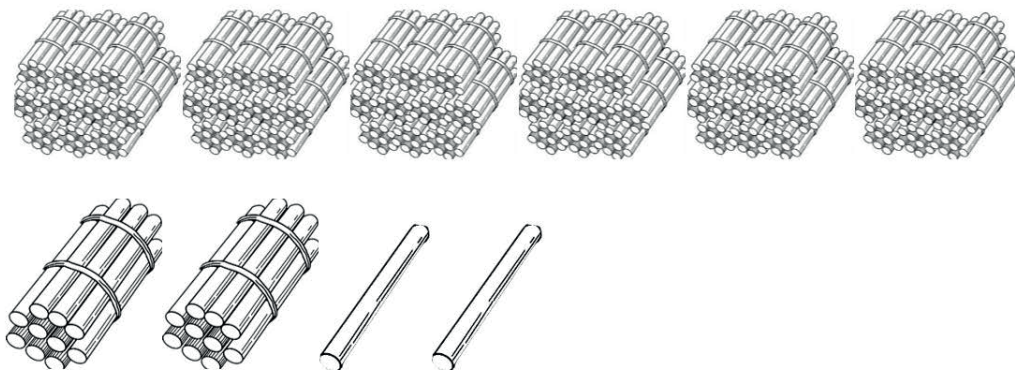

Start with the hundreds. There are 6 hundreds. We cannot share 6 equally with 18 groups.

We need to break the hundreds into tens. 6 hundreds equal 60 tens. So with the 1 ten we started with, we now have 61 tens. We can start sharing. We can share 3 tens with each of the 18 groups.

We have used up 54 of our tens. We still have seven tens to share.

We need to break the tens into ones. 7 tens equal 70 ones. So with the 2 ones we started with, we now have 72 ones. We can share 4 ones with each of the 18 groups.

18 groups

$$\begin{array}{r}
 34 \\
 18 \overline{) 612} \\
 \underline{- 54} \phantom{0} \\
 72 \\
 \underline{- 72} \\
 0
 \end{array}$$

We have used up all 72 of our ones. There is zero left. We have finished. 612 shared equally with 18 groups, gives 34 in each group.

612 divided by 18 is 34.

$$612 \div 18 = 34$$

**Example 2**

Work out:  $4,428 \div 36$   
 Arrange vertically

$$\begin{array}{r}
 123 \\
 36 \overline{) 4428} \\
 \underline{- 36} \phantom{00} \\
 82 \phantom{0} \\
 \underline{- 72} \phantom{0} \\
 108 \\
 \underline{- 108} \\
 0
 \end{array}$$

Therefore  $4,428 \div 36 = 123$

Divide

$$44 \div 36 = 1$$

$$82 \div 36 = 4$$

**Example 3**

Share equally 2058 oranges among 14 people.

$$\begin{array}{r}
 147 \\
 14 \overline{) 2058} \\
 \underline{- 14} \phantom{00} \\
 65 \phantom{0} \\
 \underline{- 56} \phantom{0} \\
 98 \\
 \underline{- 98} \\
 0
 \end{array}$$

Therefore  $2,058 \div 14 = 147$

Divide

$$20 \div 14 = 1$$

$$65 \div 14 = 4$$

**Exercise**

Now work out these.

- |  |                    |
|--|--------------------|
| 1. $1,845 \div 15$   | 4. $8,996 \div 26$ |
| 2. $3,645 \div 27$   | 5. $1,500 \div 12$ |
| 3. $3,116 \div 19$   | 6. $2,880 \div 36$ |
| 7. Find the quotient of 1,806 and 21.                      |                    |
| 8. Share 7,583kg of maize flour equally among 53 families. |                    |

## Lesson 4: Dividing by a two-digit number with a remainder.

### In this lesson, you will:

- Divide numbers by 2-digit numbers with a remainder.
- Solve word problems involving dividing with the remainder.

### You will need:

- Counters
- An exercise book and a pen.
- Multiplication table at the back of your book.

### Introduction:

In the previous lesson, you learned how to divide by two-digit number, without a remainder. In this lesson you are going to divide 4-digit numbers by two digit numbers leaving a remainder. You will follow the same steps, but there will be a remainder.

### Step 1: Activity

- Get 47 counters and arrange them in nines.
- How many groups of nines are there?
- How many counters remain?  
Now write a division sentence showing the remainder.

### Step 2

#### Study the examples below.

#### Example 1

Work out 6,274 by 13

$$\begin{array}{r}
 482 \text{ remainder } 8 \\
 13 \overline{) 6274} \\
 \underline{4 \times 13 = 52} \phantom{0} \\
 107 \phantom{0} \\
 \underline{8 \times 13 = 104} \phantom{0} \\
 34 \\
 \underline{2 \times 13 = 26} \\
 8
 \end{array}$$

**Therefore**  $6274 \div 13 = 482 \text{ remainder } 8$   
 Divide  
 $62 \div 13 = 4$   
 $107 \div 13 = 8$   
 $34 \div 13 = 2 \text{ remainder } 8$

#### Example 2

In a county there are 48 stores for maize.

If the country puts 5,290 tonnes in the stores, how many tonnes remain?

$$\begin{array}{r}
 110 \text{ remainder } 10 \\
 48 \overline{) 5290} \\
 \underline{1 \times 48 = 48} \phantom{0} \\
 49 \phantom{0} \\
 \underline{1 \times 48 = 48} \phantom{0} \\
 10 \\
 \underline{0 \times 48 = 0} \\
 10
 \end{array}$$

### Exercise

Work out the following.

1.  $527 \div 25$

3.  $1,528 \div 12$

2.  $9,053 \div 37$

4.  $33,482 \div 31$

5. Share 41,384 seedlings among 29 farmers. How many seedlings remain?

6. 1,489 books were shared by 20 schools equally. How many books remained?

### **Lesson 5: Mixed operations on whole numbers.**

#### **In this lesson, you will:**

- Read problems of mixed operations on whole numbers.
- Work out problems of mixed operations on whole numbers.

#### **You will need:**

- Counters
- An exercise book
- A pen.

#### **Introduction:**

Mathematics is a subject order. This is true in many ways, but one of them is the way you handle questions with 2 or more operations.

In this lesson, you are going to learn the order followed.

The word '**BODMAS**' is your guide.

B – Brackets.

O – Of (means x)

D – Division.

M – Multiplication.

A – Addition.

S – Subtraction.

The knowledge of mixed operations will help you to always have order in the way you do things in your life and to know which one comes first and why.

#### **Step 1**

##### **Activity**

- Count 30 sticks, then 12 more sticks.
- Put  $\frac{1}{2}$  of the sticks aside.
- How many sticks do you remain with?

**Step 2****Study the examples below.****Example 1**Work out:  $7 + (4 \times 3)$ 

First remove brackets.

$$7 + 12$$

Then add

$$7 + 12 = 19$$

**Example 2**Work out  $4 - 7 + 12$ 

First arrange and add

$$\begin{aligned} 4 + 12 - 7 &= 16 - 7 \\ &= 9 \end{aligned}$$

**Exercise**

Work out

1.  $6 + 2 \times 4$

6.  $12 \times 9 \div 3$

2.  $7 - 2 \times 3 + 1$

7.  $18 - (3 \times 8) \div 6$

3.  $3 - 1 \times 2$

8.  $\frac{1}{2}$  of  $20 + 9$

4.  $30 \div 6 - 4 \div 2$

9.  $20 \div 4 - 2 + 1$

5.  $10 - 6 \div 2 + 1$

10.  $8 - 2 \times 3 + 4$

**Lesson 6: Word problems involving mixed operations.****In this lesson, you will:**

- Read word problems involving mixed operations.
- Solve word problems involving mixed operations.

**You will need:**

- Bottle tops.
- An exercise book.
- A pen.

**Introduction:**

You have **learnt** how to deal with mixed operations on whole numbers. It is important to remember the order BODMAS and how to follow it.

This will greatly help you to form and interpret mathematical sentences from the word problem.

**Step 1**

**Activity**

- Put 9 groups of 3 counters in a container.
- Take away 10 counters from the container.
- How many counters have remained in the container?  
Write the mathematical sentence formed.

**Step 2**

**Now study this example**

**Example**

Peter had 142 books, he gave 56 to Angelo. He then bought 17 more books. How many books does Peter have now?

**Add**

$$\begin{array}{r} 142 \\ +17 \\ \hline \end{array}$$

$$159$$

**Subtract.**

$$\begin{array}{r} 159 \\ -56 \\ \hline \end{array}$$

$$103$$

$$142 \text{ books} - 56 \text{ books} + 17 \text{ books}$$

$$142 - 56 + 17$$

$$(142 + 17) - 56$$

$$103 \text{ books}$$

Peter now has 103 books.

Follow the order by re arranging

form a mathematical sentence

**Exercise**

Now work out the following in your exercise book.

1. A girl collected 46 oranges from the garden. She sold 29 to a market vendor. She later collected 15 more oranges. How many oranges did she remain with?
2. Sandra made 7 groups of 4 tomatoes and used 12 tomatoes for sauce. How many tomatoes remained?
3. Otim reared 40 rabbits. He sold  $\frac{1}{4}$  of them. How many rabbits did Otim sell?
4. Natukunda had sh.4000 and her father gave her sh.6000 more. She bought a geometry set for sh.2500. How much money did she remain with?



## Lesson 7: Grouping and counting in base five (fives)

### In this lesson, you will:

- Make groups of five.
- Count in fives.
- Draw groups for numbers in base five.

### You will need:

- Counters
- An exercise book.
- A pen.
- A ruler and a pencil.

### Introduction:

In term one you learnt about grouping in tens, hundreds and thousands. In this lesson you are going to learn about grouping and counting in base five.

Your family might have bought tomatoes in heaps. Sometimes the tomatoes are in heaps of 5 (fives) that is base five in real life.

You also learned how to divide leaving a remainder. This is going to be helpful as you will notice in the activity and examples.

### Step 1

#### Activity

- Get 19 counters and make groups of five.

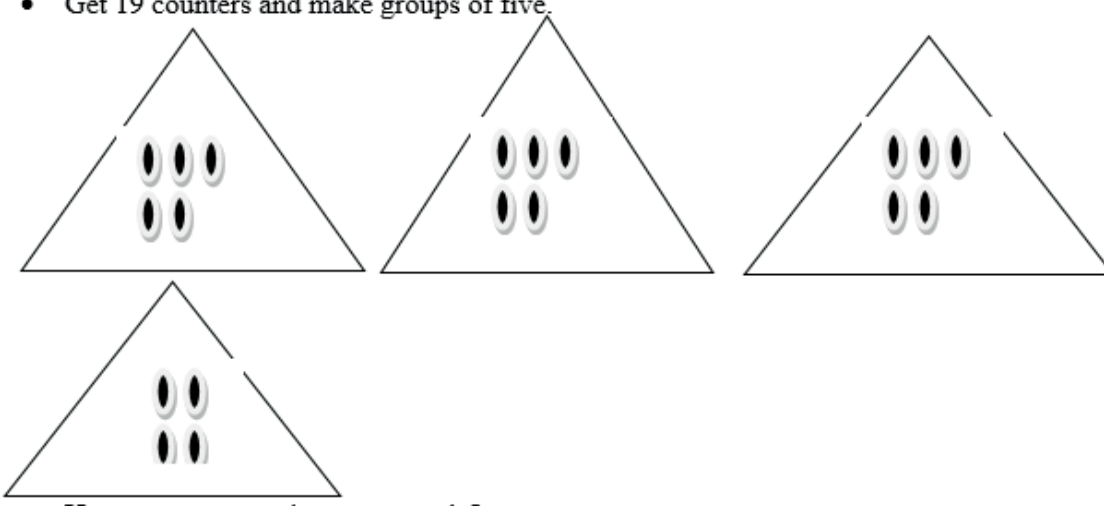

- How many groups have you made?
- How many counters remain?

This can be written as  $34_{\text{five}}$ .  
Read as three four base five.

Now study the example below.

You are going to group numbers in fives using counters. Take note of the remainder. Don't worry even if its zero.

**Step 2**

**Example**

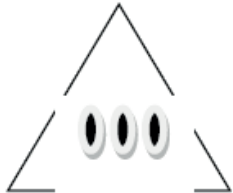
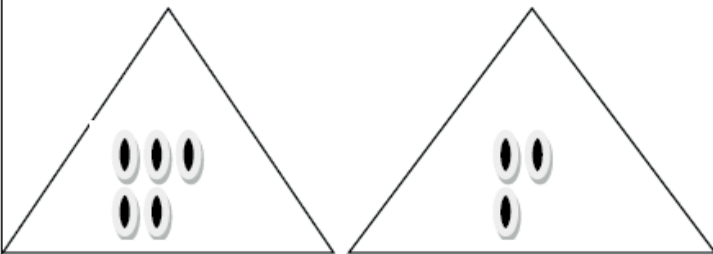
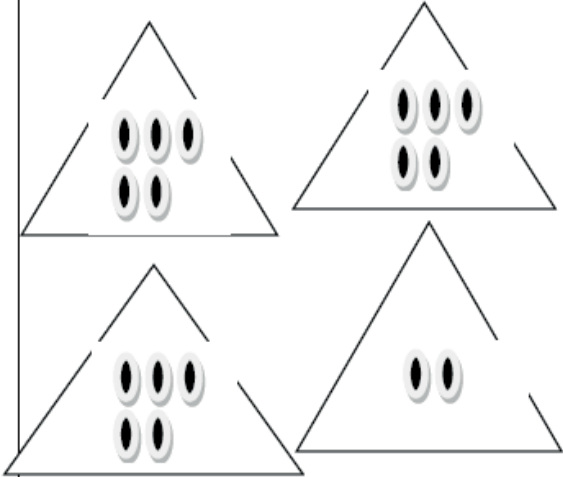



Number in base ten	Grouping in fives	Number in base five
3	 <p>3 ones</p>	3 <sub>five</sub>
8	 <p>1 five 3ones</p>	13 <sub>five</sub> .
17	 <p>3 fives 2 ones</p>	32 <sub>five</sub> .

<p>35</p>		<p><math>120_{\text{five}}</math>.</p>
	<p>1 five fives 2 fives 0 ones.</p>	

Note: The digits used in base five are 0,1,2,3 and 4.

**Exercise**

1. Group the following in fives and write the number in base five.

Objects	Grouping in fives	Number in base five
		
		
		
		

1. Draw groups for the following numbers in base five.

- a)  $11_{\text{five}}$
- b)  $21_{\text{five}}$
- c)  $24_{\text{five}}$

### Lesson 8: Place value in base five.

**In this lesson, you will:**

- Identify the place value of digits in numbers in base five.
- Write the place values of digits in base five.

**You will need:**

- Cards with digits 0, 1, 2, 3, 4
- Counters

**Introduction:**

In the term one, you learned how to identify place value of digits in whole numbers. Remember words like ones, tens, hundreds.

In this lesson, you are going to identify place value of digits in base five.

**Step 1**

**Activity**

Make cards like the ones below.

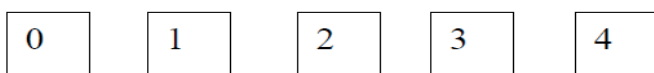

Draw a table like the one below in your exercise book.

Five five fives	Five fives	Fives	Ones

- Place the cards in the table according to your choice. Do not begin with zero.
- Write the number you have formed.
- Read the number digit by digit in base five.

**Step 2****Now study the example below**

What is the place value of each digit in  $23_{\text{five}}$

a)  $2 \quad 3_{\text{five}}$

b)  $1 \quad 2 \quad 2_{\text{five}}$

**Exercise**

1. Write the place value of each digits in the numbers below:

a)  $14_{\text{five}}$ .                      b)  $102_{\text{five}}$                       c)  $231_{\text{five}}$ .

2. Fill in the missing numbers.

a)  $13_{\text{five}} =$  \_\_\_\_\_ fives \_\_\_\_\_ ones.

b)  $103_{\text{five}} =$  \_\_\_\_\_ five fives \_\_\_\_\_ fives \_\_\_\_\_ ones.

c)  $342_{\text{five}} =$  \_\_\_\_\_ five fives \_\_\_\_\_ fives \_\_\_\_\_ ones.

d)  $134_{\text{five}} =$  \_\_\_\_\_ five fives \_\_\_\_\_ fives \_\_\_\_\_ ones.

e)  $122_{\text{five}} =$  \_\_\_\_\_ five fives \_\_\_\_\_ fives \_\_\_\_\_ ones.

**Lesson 9: Adding numbers in base five.****In this lesson, you will:**

- Group numbers in base five
- Add numbers in base five.

**You will need:**

- Counters
- An exercise book and a pen.

**Introduction:**

In the previous lesson, you learnt about place Value in base five. Whenever you are adding, arrange the digits according to their place values vertically.

Any number above 4 should be regrouped.

You are going to carry out these steps in the activity.

### Step 1

#### Activity

- Get two sets of counters; one set contains 14 counters and another 17 counters.
- Now group 14 in fives

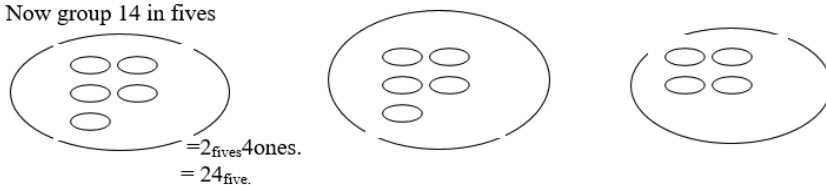

- Then group 17 in fives.

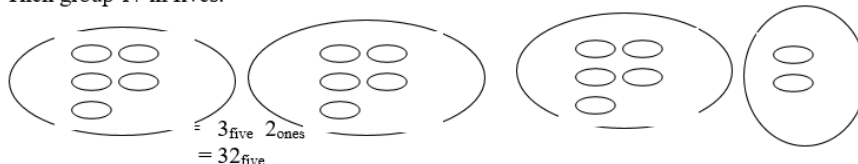

- Now join all the groups.

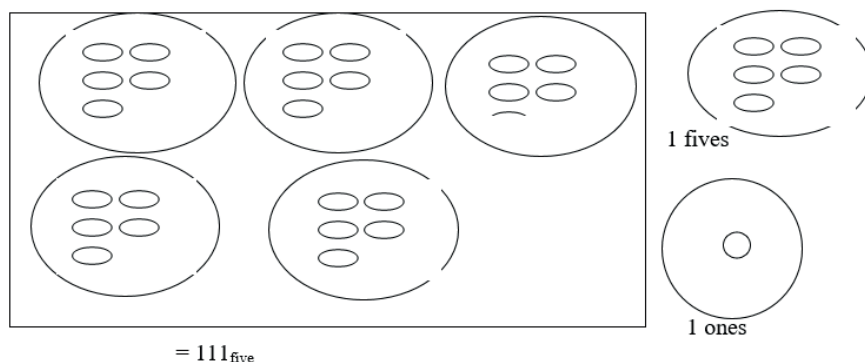

### Step 2

Now study the examples below

#### Example 1

Add  $13_{\text{five}} + 11_{\text{five}}$

$$\begin{array}{r} 1 \ 3_{\text{five}} \\ + 1 \ 1_{\text{five}} \\ \hline 2 \ 4_{\text{five}} \end{array}$$

#### Example 2

Add  $122_{\text{five}} + 114_{\text{five}}$

$$\begin{array}{r} 122_{\text{five}} \\ + 114_{\text{five}} \\ \hline 241_{\text{five}} \end{array}$$

$$\begin{array}{l} 2+4=6 \\ 6 \div 5 = 1 \text{ rem } \_ \end{array}$$

### Exercise

Work out

1.  $2_{\text{five}} + 1_{\text{five}}$

4.  $23_{\text{five}} + 22_{\text{five}}$

6.  $101$   
 $+234_{\text{five}}$

2.  $3_{\text{five}}+2_{\text{five}}$

5.  $103_{\text{five}}$   
 $+23_{\text{five}}$

7.  $2 \ 4_{\text{five}}$   
 $+2 \ 3_{\text{five}}$

3.  $11_{\text{five}} + 12_{\text{five}}$

\_\_\_\_\_

## Lesson 10: Subtracting numbers in base five.

### In this lesson, you will:

- Subtract numbers in base five.
- Regroup while subtracting

### You will need:

- Counters
- An exercise book and a pen.

### Introduction:

In the previous lesson, you learnt how to regroup while adding.

Subtraction in base five, too, requires the knowledge of regrouping.

In base ten, while regrouping, 1 contains 10.

In base five while regrouping, 1 contains 5.

It is easier to subtract vertically, so you will arrange the digits properly according to their place values before you subtract.

The knowledge of subtracting in base five, helps people who sell in the market to know the number of heaps they have sold and how many they have remained.

### Step 1 Activity

- Count 24 counters and subtract 9 counters.
- Group them in fives as shown below.
- Do you realize that 4 have remained.
- So you have 44 base five.
- Also regroup 9 counters in fives. You will realize that you have one five and four remain.
- So you have 14 base five.
- 24 counters

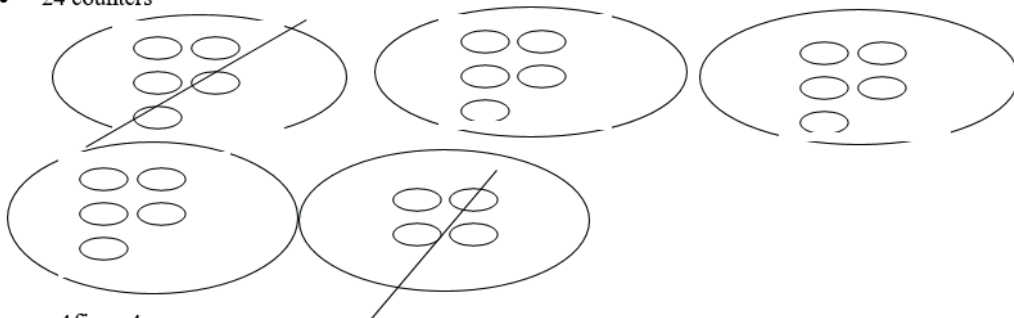

= 4 fives 4 ones.

- Take away 9 counters

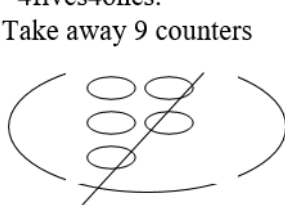

= 1 five 4 ones.

Therefore

$$\begin{array}{r} 44_{\text{five}} \\ - 14_{\text{five}} \\ \hline 30_{\text{five}} \end{array}$$

You can now study these examples.

<p><b>Example 1</b> Work out: <math>123_{\text{five}} - 42_{\text{five}}</math></p> $\begin{array}{r} 07 \\ \cancel{1} \cancel{2} 3_{\text{five}} \\ - 42_{\text{five}} \\ \hline 31_{\text{five}} \end{array}$	<p><b>Example 2</b> Work out <math>431_{\text{five}} - 34_{\text{five}}</math></p> $\begin{array}{r} 38 \\ \cancel{4} \cancel{3} 1_{\text{five}} \\ - 34_{\text{five}} \\ \hline 4_{\text{five}} \end{array}$
---	---

**Exercise**

Work out:

1.  $34_{\text{five}} - 12_{\text{five}}$

6.  $3021_{\text{five}}$

7.  $1030_{\text{five}}$

$-410_{\text{five}}$

$-221_{\text{five}}$

2.  $21_{\text{five}} - 14_{\text{five}}$

\_\_\_\_\_

\_\_\_\_\_

3.  $100_{\text{five}} - 22_{\text{five}}$

4.  $413_{\text{five}} - 44_{\text{five}}$

8.  $2341_{\text{five}}$

$-410_{\text{five}}$



## Topic: Patterns and sequences

### Lesson 1: Types of numbers

#### In this lesson, you will:

1. Identify triangular numbers.
2. Identify square numbers
3. Identify composite numbers
4. Identify prime numbers.

**You will need:** a pen, a pencil, a book, counters.

#### Introduction

Patterns help you to learn sequences and make estimates. This brings order in what you do and make. For example, look at laying bricks while building a house, they make good patterns, Weaving among others. You have already seen in primary four that patterns and sequences can be made also using numbers. Number patterns and sequences are written in series. Knowing about number patterns will help you to learn how to make designs.

#### Triangular numbers

When you add consecutive counting numbers from 1, the sum is always a triangle number. To understand this better try the activity below.

#### Step 1

Get counters and arrange them as shown below.

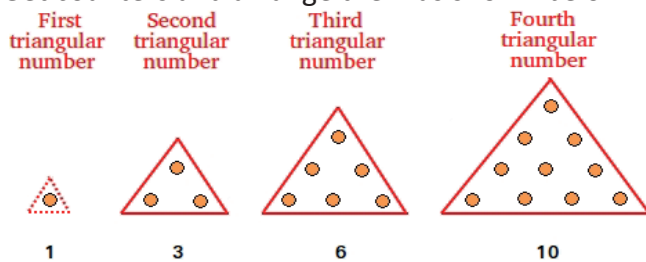

#### Triangular numbers

- What shape have the counters formed? The shape is a triangle.
- The number of counters in each pattern is the sum of consecutive counting numbers from 1. That is to say:
 

1	=	1
1+2	=	3
1+2+3	=	6
1+2+3+4	=	10
- The sums form a set of triangle numbers.

## Step 2

Look at the sequence of triangular numbers below

$$1 = 1$$

$$1 + 2 = 3$$

$$1 + 2 + 3 = 6$$

$$1 + 2 + 3 + 4 = 10$$

$$1 + 2 + 3 + 4 + 5 = 15$$

A set of triangle numbers include: 1, 3, 6, 10, 15,...

Look at the following examples

1. Find the 5<sup>th</sup> triangular number
  - First list the first 5 counting numbers  
1, 2, 3, 4, 5
  - Add the first 5 counting numbers  
 $1 + 2 + 3 + 4 + 5 = 15$

Therefore, the 5<sup>th</sup> triangular number is 15.

2. Write the next number in the sequence

1, 3, 6, 10, 15, 21,-----

The sequence increases by adding consecutive counting numbers as shown below

$$1 + 2 = 3$$

$$3 + 3 = 6$$

$$6 + 4 = 10$$

$$10 + 5 = 15$$

$$15 + 6 = 21$$

$$21 + 7 = 28$$

The next number in the sequence is: 1, 3, 6, 10, 15, 21, 28

## Exercise

1. Write down the first 4 triangular numbers.
2. What is the sum of the first and fifth triangular numbers?
3. Find the sum of the first three triangular numbers.

## Square numbers

### Step 1: Activity

- Draw many small squares.
- Arrange them to form different squares as shown below.

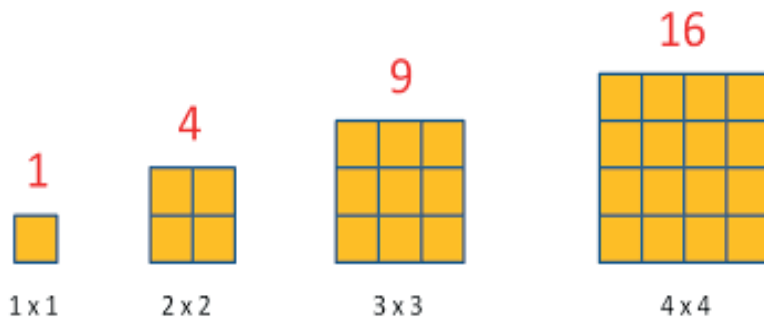

- Count the number of small squares in each of the given squares

The small squares in each pattern are:

First pattern = 1 square

Second pattern = 4 squares

Third pattern = 9 squares

Fourth pattern = 16 squares

- How many small square pieces will the next square pattern have?  
The next square pattern will have:  $5 \times 5 = 25$  squares

Note that square numbers are numbers obtained when a number is multiplied by itself.

## Step 2

Look at the following examples:

- Write the first 8 square numbers  
Square numbers are obtained by multiplying a number by itself.  
 $1 \times 1 = 1$   
 $2 \times 2 = 4$   
 $3 \times 3 = 9$   
 $4 \times 4 = 16$   
 $5 \times 5 = 25$   
 $6 \times 6 = 36$   
 $7 \times 7 = 49$   
 $8 \times 8 = 64$     The numbers are : 1, 4, 9, 16, 25, 36, 49, 64
- Find the missing number in the sequence below  
1, 4, 9, 16, 25, 36, -----  

1	4	9	16	25	36	<u>49</u>
$1 \times 1$	$2 \times 2$	$3 \times 3$	$4 \times 4$	$5 \times 5$	$6 \times 6$	$7 \times 7$

The missing number is 49.

## Exercise

- Write down the first 5 square numbers.
- What is the sum of the third and seventh square numbers?
- Find the sum of the first 4 square numbers.

## Composite numbers

### Step 1

- Write the following numbers on papers as shown below:



- Pick any number, find and record its factors  
- Example:
 

number	factors
7	1, 7

- Group papers with numbers which have only two factors

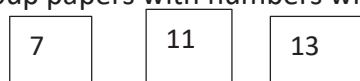

- Group papers with numbers which have more than two factors

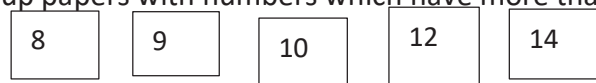

- Give a common name for each of the groups

Numbers with only 2 factors are called prime numbers and numbers with more than 2 factors are called composite numbers.

**Note: composite numbers are numbers with more than 2 factors.**

### Step 2

Look at the following examples:

- Write down the first 6 composite numbers  
The first 6 composite numbers are:  
4, 6, 8, 9, 10, 12.
- List the factors of 24 and write composite or not composite.  
Think of two numbers whose product is 24.  
 $1 \times 24 = 24$   
 $2 \times 12 = 24$   
 $3 \times 8 = 24$   
 $4 \times 6 = 24$  The factors of 24 are: { 1, 2, 3, 4, 6, 8, 12, 24 }. 24 is a composite number.  
 Or  
 $24 \div 1 = 24$   
 $24 \div 2 = 12$   
 $24 \div 3 = 8$   
 $24 \div 4 = 6$   
 $24 \div 6 = 4$

$$24 \div 8 = 3$$

$$24 \div 12 = 2$$

$$24 \div 24 = 1 \quad \text{The factors of 24 are: } \{ 1, 2, 3, 4, 6, 8, 12, 24.\}. \quad 24 \text{ is a composite number.}$$

**Exercise.**

1. Write down the first four composite numbers.
2. Find the sum of the first and fifth composite numbers.
3. What is the sum of the first three composite numbers?

**Prime numbers**

Prime numbers are numbers with only two different factors, that is 1 and itself.

To learn more about prime numbers do the following activity.

**Step 1**

- Write numbers 1 to 100 as shown below:

1	2	3	4	5	6	7	8	9	10
11	12	13	14	15	16	17	18	19	20
21	22	23	24	25	26	27	28	29	30
31	32	33	34	35	36	37	38	39	40
41	42	43	44	45	46	47	48	49	50
51	52	53	54	55	56	57	58	59	60
61	62	63	64	65	66	67	68	69	70
71	72	73	74	75	76	77	78	79	80
81	82	83	84	85	86	87	88	89	90
91	92	93	94	95	96	97	98	99	100

- Cross out 1
- Leave 2, 3, 5 and 7 but cross all the multiples of 2, 3, 5 and 7.
- List all numbers which are not crossed/in a circle. What type of numbers are they?

Well, the expected answers are shown below:

1	②	③	4	⑤	6	⑦	8	9	10
⑪	12	⑬	14	15	16	⑰	18	⑱	20
21	22	⑳	24	25	26	27	28	㉑	30
⑳	32	33	34	35	36	㉗	38	39	40
④	42	④	44	45	46	④	48	49	50
51	52	⑤	54	55	56	57	58	⑤	60
⑥	62	63	64	65	66	⑥	68	69	70
⑦	72	⑦	74	75	76	77	78	⑦	80
81	82	⑧	84	85	86	87	88	⑧	90
91	92	93	94	95	96	⑨	98	99	100

Numbers which are not crossed: 2, 3, 5, 7, 11, 13, 17, 19, 23, 29, 31, 37, 41, 43, 47, 53, 59, 61, 67, 71, 73, 79, 83, 89, 97. These are prime numbers.

**Step 2**

Look at the following examples:

1. Write a list of prime numbers less than 50  
The expected answer is right here.  
2, 3, 5, 7, 11, 13, 17, 19, 23, 29, 31, 37, 41, 43, 47
2. Write a list of prime numbers between 0 and 10  
These include: 2, 3, 5, 7

**Exercise**

1. List all the triangular numbers less than 20
2. What is the 7<sup>th</sup> triangular number?
3. What is the sum of the first and third triangular numbers?
4. What is the sum of the first 10 counting numbers?
5. Fill in the next three missing numbers in the sequence: 1, 3, 6, 10, -----, -----, -----.
6. Find the missing numbers in the sequence: 1, 4, 9, 16, -----, -----
7. Find the next number in the sequence: 100, 81, 64, 49, 36, -----
8. List all the prime numbers less than 20
9. Write the prime numbers between 20 and 30
10. Find the next number in the sequences below:
  - a) 2, 3, 5, 7, -----
  - b) 19, 23, 29, 31, -----
  - c) 47, 53, 59, -----

## Lesson 2: Factors and multiples of numbers

### In this lesson, you will:

1. Find the factors of numbers.
2. Describe what factors are.
3. Find the multiples of numbers.
4. Describe multiples of numbers.

**You will need:** a pen, a book, a pencil

### Introduction

Take about 20 seconds to think about the meaning of the word factor (s). We'll compare your explanation with the one given below.

- Factor (s) is any number that is divisible by another number with a remainder of 0 or factors are the whole numbers you multiply to get another number. This topic helps you to predict the multiplication effect of an event, for example the number of people who may contract a disease.

To get the real meaning of this, do the following activity

#### Step 1

Think of any whole number. No matter which one you pick, there are two whole numbers you can multiply to get your number.

Suppose you picked 7.

$1 \times 7 = 7$ . The numbers 1 and 7 are called factors of 7.

- Some numbers have more than 2 factors.
- Find all the factors of 12

#### Step 2

Look at the following examples

**Example 1.** List the factors of 12

$$1 \times 12 = 12$$

$$2 \times 6 = 12$$

$$3 \times 4 = 12$$

Therefore the factors of 12 are: { 1, 2, 3, 4, 6, 12 }

**Example 2.** Find the common factors of 16 and 24

Factors of 16

$$1 \times 16 = 16$$

$$2 \times 8 = 16$$

$$4 \times 4 = 16$$

Therefore the factors of 16 are : { 1, 2, 4, 8, 16 }

Factors of 24

$$1 \times 24 = 24$$

$$2 \times 12 = 24$$

$$3 \times 8 = 24$$

$$4 \times 6 = 24$$

The factors of 24 are: { 1, 2, 3, 4, 6, 8, 12, 24 } **Check, underline the common factors.**

The factors of 16 are: { 1, 2, 4, 8, 16 }

Common factors of 16 and 24 are: { 1, 2, 4 }

### Exercise.

1. List the factors of 5
2. Write down the factors of 16.
3. Find the common factors of 8 and 10.

### Multiples of numbers

Multiples of a number are the products of that number and any whole number. Multiples and factors help you to break down numbers to make multiplication and division easier.

#### Step 1: Activity.

Would you please count aloud in threes starting with 3 up to 36.

Now write down your answers. Am sure they must be similar to the ones below:

3, 6, 9, 12, 15, 18, 21, 24, 27, 30, 33, 36.

**Example 1.** Find the first 6 multiples of 5

$$1 \times 5 = 5$$

$$2 \times 5 = 10$$

$$3 \times 5 = 15$$

$$4 \times 5 = 20$$

$$5 \times 5 = 25$$

$$6 \times 5 = 30;$$

Therefore the first 6 multiples of 5 are: { 5, 10, 15, 20, 25, 30 }

### Exercise

1. Write **down** the first 7 multiples of each of the following:  
a) 2   b) 4   c) 5   d) 6   e) 7   f) 8   g) 10
2. Find the multiples of 10 greater than 30 but less than 100.
3. Circle the multiples of 4 in the list below: 4, 10, 8, 14, 12, 18, 16, 22, 24, 60
4. List the factors of 18



5. Write down the factors of 32
6. List the factors of 28
7. Find the common factors of 12 and 20
8. Find the common factors 18 and 15
9. Find the common factors of 90 and 120

### Lesson 3: Lowest common multiple (LCM)

#### In this lesson, you will:

1. Work out the LCM of numbers.
2. Describe what LCM is.

**You will need:** a paper, a book, a pen.

#### Introduction

In the previous lesson you learnt about multiples of numbers. In today's lesson you are going to learn about Lowest common multiple which is written as LCM in short form. The lowest common multiple of two or more numbers is the smallest number that is a multiple of **two or more** numbers. The knowledge of LCM will help you to develop critical thinking skills which will enable you to share items without remainders.

#### Step 1

1. Write the multiples of 4 and 5 on papers as shown below:

4	8	12	16	20	24	28	32	36	40	44
5	10	15	20	25	30	35	40	45	50	55

Pick all the papers with common multiples

20	40
----	----

2. What is the lowest of the multiples you have picked?

The lowest common multiple of 4 and 5 is 20.

#### Step 2

##### Look at the following examples

1. Find the lowest common multiple of 3 and 4  
 Step 1: List the multiples of 3; 3, 6, 9, 12, 15.  
 Step 2: List the multiples of 4; 4, 8, 12, 16.  
 12 is a common multiple of 3 and 4, so it is the lowest common multiple of 3 and 4.
2. Find the lowest common multiple of 5 and 8

Multiples of 5: 5, 10, 15, 20, 25, 30, 35, 40, 45

Multiples of 8: 8, 16, 24, 32, 40, 48

40 is a common multiple of 5 and 8

Therefore the LCM of 5 and 8 is 40

### Exercise

Find the lowest common multiple of the following:

- a) 5 and 10    b) 3 and 9    c) 4 and 5    d) 5 and 9    e) 15 and 30    g) 8 and 12

## Lesson 4: Greatest common factor(GCF)

### In this lesson, you will:

1. Work out the greatest common factor (GCF) of numbers.
2. Describe what greatest common multiple (GCF) is.

**You will need:** a pencil, a pen, a book, cards

### Introduction

You looked at factors of numbers in the previous lesson where we emphasized that a factor is any number that is divisible by another number. In today's lesson, we are going to learn about Greatest common factor which is written as GCF in short form. The greatest common factor (GCF) of two or more numbers is the largest number that is a factor of both numbers. Greatest common factor is also called Highest common factor (HCF). The knowledge of GCF will help you to develop creative thinking skills which will enable you to divide numbers without remainders.

### Step 1

- Find the factors of 6 and 9
- Compare the factors and find the common factors.
- Find the highest common factor.

Factors of 6

$$1 \times 6 = 6$$

$$2 \times 3 = 6$$

Factors of 6: {1, 2, 3, 6.}

Factors of 9

$$1 \times 9 = 9$$

$$3 \times 3 = 9$$

Factors of 9: {1, 3, 9.} **Check, underline the common factors.**

Common factors of 6 and 9 are: {1, 3.}

The highest common factor of 6 and 9 is 3.

### Step 2

Look at the following examples

1. What is the greatest common factor of 12 and 18?

Step 1: List all the factors of 12

$$1 \times 12 = 12$$

$$2 \times 6 = 12$$

$$3 \times 4 = 12$$

The factors of 12 are : {1, 2, 3, 4, 6, 12}

Step 2: List the factors of 18

$$1 \times 18 = 18$$

$$2 \times 9 = 18$$

$$3 \times 6 = 18$$

The factors of 18 are: {1, 2, 3, 6, 9, 18} **Check, underline the common factors.**

The factors of 12 are: {1, 2, 3, 4, 6, 12}

The common factors of 24 and 18 are: {1, 2, 3, 6}

Therefore 6 is the greatest common factor of 24 and 18

### Step 3

#### Exercise

Find the greatest common factor of the following:

- a) 8 and 12   b) 10 and 15   c) 18 and 24   d) 8 and 9   e) 28 and 42   g) 40 and 72

## Lesson 6: Number patterns

**In this lesson, you will:**

1. Form patterns in increasing and decreasing progression.
2. Read patterns and sequences.

**You will need:** a pencil, a pen, a book.

### Introduction

Number patterns and sequences are established by a common relationship between- numbers.

Number patterns whose next number is got by addition or multiplication are said to be in increasing progression.

Patterns whose next number is got by subtraction or division are said to be in decreasing progression. This topic will help you to develop problem solving skills which will enable you to Count easily when you see the number patterns for example you can use number patterns to count by tens, such as groups of 10 tomatoes.

To understand this better try the activity below.

### Step 1

a)

- Draw a figure similar to the one below on a piece of paper.

1    2    3    4    5    6    7    8    9    10    11

*		*								
---	--	---	--	--	--	--	--	--	--	--

- Draw a star into the figure but keep on skipping one box.
- Record the number of boxes which have stars.
- What do you notice?

Well, the expected answer is shown below:

1	2	3	4	5	6	7	8	9	10	11
*		*		*		*		*		*
1, 3, 5, 7, 9, 11.										

The numbers in the sequence are increasing by 2.

b) Write the following numbers on papers as shown below:

130	115	140	120	135	125
-----	-----	-----	-----	-----	-----

Arrange the numbers from the largest to the smallest, what do you notice?

Well, the expected answer is shown below:

140	135	130	125	120	115
-----	-----	-----	-----	-----	-----

The numbers are decreasing by 5.

## Step 2

Look at the following examples

1. Find the missing number in the sequence below

20, 30, 40, 50, 60, -----

When you study the sequence carefully, you realize that it increases by 10. So keep adding 10 to get the next number as shown below

$$20 + 10 = 30$$

$$30 + 10 = 40$$

$$40 + 10 = 50$$

$$50 + 10 = 60$$

$$60 + 10 = 70$$

Therefore the sequence is : 20, 30, 40, 50, 60, 70

Or

Multiply consecutive counting numbers by 10 to get the next number.

$$2 \times 10 = 20$$

$$3 \times 10 = 30$$

$$4 \times 10 = 40$$

$$5 \times 10 = 50$$

$$6 \times 10 = 60$$

$$7 \times 10 = 70$$

20, 30, 40, 50, 60, 70

2. Find the next number in the sequence below:

50, 45, 40, 35, 30, -----

The sequence decreases by 5. So keep subtracting 5 to get the next number as shown below.

$$50 - 5 = 45$$

$$45 - 5 = 40$$

$$40 - 5 = 35$$

$$35 - 5 = 30$$

$$30 - 5 = 25$$

Therefore the sequence is : 50, 45, 40, 35, 30, 25

### Step 3

#### Exercise

1. Find the next number in the following sequences

a) 18, 20, 22, 24, 26,-----

b) 75, 80, 85, 90, 95,-----

c) 12, 15, 18, 21, 24,-----

d) 20, 18, 16, 14, 12,-----

e) 80, 75, 70, 65, 60,-----

f) 52, 48, 44, 40, 36,-----

2. Find the next two numbers in the sequence

10, 30, 50, 70, 90, -----, -----

## Topic: FRACTIONS.

### Lesson 1: Addition of fractions with different denominators.

#### In this lesson, you will:

- Find the lowest common denominator of fractions.
- Add fractions with different denominators using LCD.

#### You will need:

- Sheets of paper and a ruler.
- A pen and an exercise book.

#### Introduction:

In the previous lessons, you learnt how to find Lowest Common Multiples of numbers. This is going to help you greatly to find the Lowest Common Denominators of fractions. In this lesson, Lowest Common Multiple is going to be used as Lowest Common Denominator. This will, in turn, help you find the equivalent fractions to ease addition. The knowledge of adding fractions helps you to tell what part or how many parts of a whole you have used.

#### Step 1

#### Try this activity

Get three strip cards and divide them into 4 equal parts

Shade  $\frac{1}{2}$  and  $\frac{1}{4}$  on the third strip.

What fraction is shaded?  
Therefore  $\frac{3}{4}$  is shaded.

**Art work:** Shade 2 squares out of 4.

**Art work:** Shade 1 square out of 4

**Art work:** shade 3 squares out of 4

**Step 2**

Now study the examples below

**Example 1**  
 Work out  $\frac{1}{2} + \frac{1}{3}$   
 Find the lowest common Denominator (LCD) of  $\frac{1}{2}$  and  $\frac{1}{3}$   
 Multiples of 2; (2, 4, 6, 8...)  
 Multiples of 3; (3, 6, 9, 12...)  
 LCD is 6

$$\begin{array}{r} (\frac{1}{2} \times 6) + (\frac{1}{3} \times 6) \\ \hline \quad \quad 6 \quad \quad 6 \end{array}$$

Divide  
 $6 \div 2 = 3$   
 $6 \div 3 = 2$

$$\frac{3}{6} + \frac{2}{6} = \frac{5}{6}$$

Add the equivalent fractions

**Example 2**  
 Work out  
 $\frac{1}{12} + \frac{5}{6}$   
 Find the LCD of  $\frac{1}{12}$  and  $\frac{5}{6}$   
 Multiples of 12; (12, 24, 36...)  
 Multiples of 6; (6, 12, 18, 24...)  
 LCD = 12

$$\begin{array}{r} (\frac{1}{12} \times 12) + (\frac{5}{6} \times 12) \\ \hline \quad \quad 12 \end{array}$$

$12 \div 12 = 1$   
 $1 \times 1 = 1$

$12 \div 6 = 2$   
 $5 \times 2 = 10$

$$\begin{aligned} \frac{1}{12} + \frac{10}{12} &= \frac{1+10}{12} \\ &= \frac{11}{12} \end{aligned}$$

Add the equivalent fractions



**Exercise**

You can now do this exercise.

Work out.

1.  $\frac{1}{2} + \frac{1}{3}$

6.  $\frac{1}{6} + \frac{2}{3}$

2.  $\frac{1}{5} + \frac{1}{10}$

7.  $\frac{3}{4} + \frac{1}{2}$

3.  $\frac{1}{2} + \frac{1}{5}$

8.  $\frac{1}{3} + \frac{2}{5}$

4.  $\frac{2}{3} + \frac{3}{4}$

5.  $\frac{3}{10} + \frac{2}{5}$

**Lesson 2: Word problems involving addition of fractions.****In this lesson, you will:**

- Read word problems involving addition of fractions.
- Solve word problems involving addition of fractions.

**You will need:**

- Sheets of paper.
- A ruler.
- An exercise book and a pen

**Introduction:**

In the previous lesson, you learnt how to add fractions of different denominators.

In this lesson, you are going to learn how this can be applied in everyday life.

You need to read carefully the sentence, interpret it and find out what you are required to do.

**Step 1: Activity**

- Work with a brother or sister.
- Draw a rectangle and divide it into 10 equal parts.
- Let the other person draw a rectangle and divide it into 10 equal parts.
- Now shade  $\frac{2}{5}$  of the 10 parts while the other person shades  $\frac{2}{10}$  of the parts.
- What is the sum of the two fractions?

**Step 2**

Now study the examples below

**Example 1**  
 A boy ate  $\frac{1}{4}$  of his cake in the morning and  $\frac{1}{3}$  in the evening. What fraction of the cake did he eat altogether?

Morning  $\frac{1}{4}$                       find the LCD of  $\frac{1}{4}$  and  $\frac{1}{3}$   
 Evening  $\frac{1}{3}$

Multiples of 4; (4, 8, 12, 16...)  
 Multiples of 3; (3, 6, 12, 15...)  
 LCD = 12

**Add the fractions.**

$$\frac{1}{4} \text{ and } \frac{1}{3} = \frac{(\frac{1}{4} \times 12) + (\frac{1}{3} \times 12)}{12}$$

$$= \frac{3+4}{12}$$

$$= \frac{7}{12}$$

He ate  $\frac{7}{12}$  of the cake

**Divide**  
 $12 \div 4 = 3$   
 $1 \times 3 = 3$

$12 \div 3 = 4$   
 $1 \times 4 = 4$

**Example 2**  
 A trader sold  $\frac{3}{10}$  of the bag of sugar on Monday and sold  $\frac{1}{4}$  on Tuesday. Find the total fraction he sold on the two days.

Monday  $\frac{3}{10}$   
 Tuesday  $\frac{1}{4}$

find the LCD of  $\frac{3}{10}$  and  $\frac{1}{4}$   
 $M_{10} = 10, 20, 30...$   
 $M_4 = 4, 8, 12, 16, 20...$   
 LCD = 20.

$$\frac{3}{10} + \frac{1}{4} = \frac{(\frac{3}{10} \times 20) + (\frac{1}{4} \times 20)}{20}$$

$$= \frac{6+5}{20}$$

$$= \frac{11}{20}$$

**Divide**  
 $20 \div 10 = 2$   
 $3 \times 2 = 6$

**Divide**  
 $20 \div 4 = 5$   
 $1 \times 5 = 5$

**Exercise**

Now do the exercise below.

1. What is the sum of  $\frac{3}{7}$  and  $\frac{6}{14}$  ?
2. A farmer dug of  $\frac{1}{2}$  of his garden on Thursday and  $\frac{1}{3}$  on Monday. Find the fraction of the garden **he dug** on the two days.
3. Obella read  $\frac{1}{3}$  of his novel in the morning and  $\frac{1}{4}$  of the same novel in the evening. What fraction of the novel did he read altogether?
4. Kintu gave out  $\frac{1}{2}$  of his mangoes to his friends and  $\frac{1}{4}$  of the same mangoes to his sister. What fraction of the mangoes did he give out altogether?
5. Our father used  $\frac{1}{3}$  of his land for growing crops and  $\frac{2}{5}$  of the same land for rearing goats. What fraction of the land did he use altogether?

**Lesson 3: Adding mixed fractions.****In this lesson, you will:**

- Convert mixed **fractions** to improper fractions.
- Add mixed **fractions**.

**You will need:**

- Sheet of paper.
- An exercise book and a pen.
- A ruler.

**Introduction:**

In primary four you learnt about mixed fractions and improper fractions.

You also learnt how to change from a mixed fraction to an improper fraction.

If you have forgotten, do not worry, you will be reminded in the examples.

In this lesson you are going to add mixed fractions. The idea of Lowest common denominator will still help you to add mixed fractions.

Now study the examples

**Example 1**

Add :  $2\frac{1}{3} + 3\frac{1}{2}$

Change the mixed fraction to improper fraction

$$\frac{(2 \times 3) + 1}{3} + \frac{(3 \times 2) + 1}{2}$$

find the LCD of

$$\frac{7}{3} + \frac{7}{2}$$

$M_3 = (3, 6, 9, 12...)$

$M_2 = (2, 4, 6, 8...)$

$$\frac{7}{3} + \frac{7}{2}$$

$6 \div 3 = 2$      $7 \times 2 = 14$   
 $6 \div 2 = 3$      $7 \times 3 = 21$

$$\frac{7 \times 6}{6} + \frac{7 \times 6}{2}$$

The answer must be a mixed number.

$$\frac{14}{6} + \frac{21}{6} = \frac{35}{6}$$

$$= 5\frac{5}{6}$$

**Example 2**

Work out:  $1\frac{1}{4} + 2\frac{1}{2}$

Change the mixed numbers to improper.  $\frac{(1 \times 4) + 1}{4} + \frac{(2 \times 2) + 1}{2}$

$$\frac{5}{4} + \frac{5}{2}$$

Find the LCD of  $\frac{5}{4}$  and  $\frac{5}{2}$

$M_4 = (4, 8, 12 \dots)$

$M_2 = (2, 4, 6 \dots)$

LCD = 4

$4 \div 4 = 1$   
 $5 \times 1 = 5$

$$\frac{(\frac{5}{4} \times 4) + (\frac{5}{2} \times 4)}{4}$$

$4 \div 2 = 2$   
 $5 \times 2 = 10$

$$\frac{5 + 10}{4} = \frac{15}{4}$$

$$= 3\frac{3}{4}$$

**Exercise.**

Now try this exercise.

1.  $1\frac{1}{2} + 1\frac{1}{4}$

5.  $2\frac{1}{5} + 1\frac{1}{3}$

2.  $3\frac{1}{12} + 2\frac{1}{6}$

6.  $4\frac{1}{4} + 1\frac{1}{8}$

3.  $2\frac{1}{5} + 1\frac{1}{2}$

7.  $2\frac{1}{6} + 1\frac{1}{3}$

4.  $4\frac{1}{8} + 2\frac{1}{2}$

8.  $1\frac{1}{9} + 2\frac{1}{3}$

**Lesson 4: Word problems involving addition of mixed numbers.****In this lesson, you will:**

- Convert mixed **fractions** to improper fractions.
- Solve word problems involving addition of mixed numbers.

**You will need:**

- Sheets of paper.
- An exercise book and a pen.
- A ruler.

**Introduction:**

In the previous lesson you learnt how to add mixed **fractions**. In this lesson, you are going to learn how this knowledge can be applied in everyday life.

Adding mixed **fractions** helps people who work in the factory to measure capacity of liquids for example oil, paraffin and paint which sometimes can be measured in quantities of mixed **fractions**.

**Step 1: Activity**

- Collect objects with regular shapes e.g. oranges.
- Divide some of them into halves and others into quarters.
- Pick  $2\frac{1}{2}$  mangoes, then pick  $1\frac{1}{4}$
- Put them together and count them.
- How many wholes are there?
- Count the fractions.

Now study the examples below.

**Example 1**  
 Monica spends  $1\frac{1}{2}$  hours reading English and  $1\frac{1}{3}$  hours reading Mathematics.  
 Find the total time she spends reading.

English  $1\frac{1}{2}$  hours  
 Mathematics  $1\frac{1}{3}$  hours

**Add the fractions** →  $1\frac{1}{2} + 1\frac{1}{3}$

**Change mixed numbers to improper**

Find the LCD of  $\frac{3}{2}$  and  $\frac{4}{3}$

$6 \div 2 = 3$   
 $3 \times 3 = 9$

$M_2 = (2, 4, 6, 8, \dots)$   
 $M_3 = (3, 6, 9, 12, \dots)$   
 LCD is 6

**Change the answer to a mixed number.**

Find equivalent fractions  $\frac{(\frac{3}{2} \times 6)}{6} + \frac{(\frac{4}{3} \times 6)}{6}$

$6\sqrt{17}$

$2 \text{ rem. } 5$

$\frac{8}{6} + \frac{8}{6} = \frac{17}{6}$

$\frac{17}{6} = 2\frac{5}{6}$

$\frac{17}{6} = 2\frac{5}{6}$  hours

**Exercise**

- Namusoke sold  $1\frac{1}{4}$  kg of sugar to a woman and  $1\frac{1}{2}$  kg of wheat flour to a man. Find the total fraction of items Namusoke sold.
- My brother takes  $2\frac{1}{3}$  hours to do work in his exercise book. He takes  $1\frac{1}{2}$  hours to do domestic work. What fraction does he spend on the two activities?
- Find the sum of  $3\frac{1}{3}$  and  $1\frac{3}{4}$ .
- Arthur ate  $4\frac{1}{2}$  oranges. Julius ate  $2\frac{1}{5}$  oranges. Work out the total fraction both ate.
- What is the sum of  $1\frac{5}{6}$  and  $1\frac{3}{4}$ ?

## Lesson 5: Subtracting fractions with different denominators.

### In this lesson, you will:

- Find Lowest Common Denominators of fractions.
- Subtract fractions with different denominators using LCD.

### You will need:

- Sheets of paper.
- An exercise book and a pen.
- A ruler and a pencil.

### Introduction:

In the previous lesson you added fractions with different denominators. You also found the lowest common denominators of the given fractions. This helped you to find equivalent fractions.

In this lesson, you are still going to find LCD for fractions before you subtract. In order for you to subtract fractions more easily using equivalent fractions.

### Step 1 Activity

- Get a circular cutout with 8 parts.
- Shade 6 parts out of 8 parts.
- Using a cutter or a pair of scissors, cut 2 out of the 6 parts.
- What fraction of the shaded part is remaining?

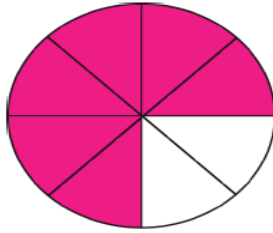

$$= \frac{6}{8} - \frac{2}{8}$$

$$= \frac{4}{8}$$

### Step 2

Now study the examples

#### Example 1

Work out  $= \frac{3}{4} - \frac{1}{2}$

The LCD of  $\frac{3}{4}$  and  $\frac{1}{2}$  is 4

$$4 \div 4 = 1$$

$$3 \times 1 = 3$$

$$\frac{(\frac{3}{4} \times 4) - (\frac{1}{2} \times 4)}{4}$$

$$4 \div 2 = 2$$

$$2 \times 1 = 2$$

Subtract

$$\frac{3}{4} - \frac{2}{4} = \frac{1}{4}$$

**Example 2**

Work out  $\frac{5}{6} - \frac{1}{4}$

Find the LCD of  $\frac{5}{6}$  and  $\frac{1}{4}$

$$M_6 = (6, 12, 18 \dots)$$

$$M_4 = (4, 8, 12 \dots)$$

$$\text{LCD} = 12$$

$12 \div 6 = 2$   
 $2 \times 5 = 10$

$$= \frac{(\frac{5}{6} \times 12) - (\frac{1}{4} \times 12)}{12}$$

$12 \div 4 = 3$   
 $1 \times 3 = 3$

Subtract

$$\frac{10}{12} - \frac{3}{12} = \frac{7}{12}$$

**Exercise**

Now try these.

1.  $\frac{3}{7} - \frac{1}{14}$

4.  $\frac{9}{10} - \frac{2}{5}$

2.  $\frac{4}{5} - \frac{1}{10}$

5.  $\frac{3}{4} - \frac{2}{3}$

3.  $\frac{4}{9} - \frac{1}{3}$

6.  $\frac{5}{6} - \frac{1}{4}$

**Lesson 6: Subtracting mixed fractions with different denominators.**

**In this lesson, you will:**

- Change mixed numbers to improper fractions.
- Subtract mixed numbers with different denominators.

**You will need:**

- Sheets of paper.
- A pen and an exercise book.

**Introduction:**

You learnt how to add mixed fractions by first of all changing them to improper fractions. In this lesson, you are going to subtract mixed fractions by first changing them to improper fractions, then you subtract. Subtraction of mixed fractions helps people, for example, in the factories, to reduce or decrease amounts of liquids as they make mixtures. Such mixtures can be of paint and oil.



**Step 1 : Activity**

- Get 5 circular cutouts
- Use a cutter or a pair of scissors to cut one of the cutouts into 8 equal parts.
- Remove 2 wholes and  $\frac{1}{8}$

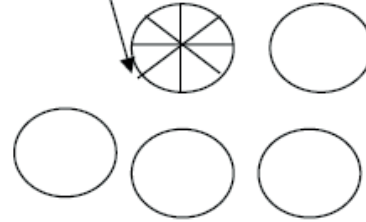

How many wholes and eighths remain?

Therefore you remain with 2 wholes and  $\frac{7}{8}$

**Step 2**

Now study this example

1. Work out  $2\frac{1}{2} - 1\frac{1}{4}$

Change to improper fractions  $\frac{5}{2} - \frac{5}{4}$

The LCD of  $\frac{5}{2}$  and  $\frac{5}{4}$  is 4

$4 \div 2 = 2$   
 $5 \times 2 = 10$

$\frac{(\frac{5}{2} \times 4)}{4} - \frac{(\frac{5}{4} \times 4)}{4}$

$\frac{10}{4} - \frac{5}{4} = \frac{5}{4}$

Subtract

$= 1\frac{1}{4}$

$4 \div 4 = 1$   
 $5 \times 1 = 5$

Change to a mixed fraction.

**Exercise**

Work out the following.

1.  $2\frac{1}{2} - 1\frac{1}{6}$

2.  $4\frac{1}{4} - 3\frac{1}{2}$

3.  $4\frac{1}{8} - 2\frac{1}{4}$

4.  $2\frac{1}{5} - 1\frac{1}{3}$

5.  $5\frac{1}{5} - 1\frac{1}{3}$

6.  $2\frac{3}{12} - 1\frac{1}{6}$

7.  $2\frac{1}{4} - 1\frac{1}{2}$

8.  $2\frac{3}{4} - 1\frac{1}{3}$

## Lesson 7: Word problems involving Subtraction of mixed fractions.

### In this lesson, you will:

- Read word problems involving subtraction of mixed **fractions**.
- Solve word problems involving subtraction of mixed **fractions**.

### You will need:

- Sheets of paper.
- A pair of scissors or a cutter.
- An exercise book and a pen.
- A pencil.

### Introduction:

Subtraction is the ‘opposite’ of addition.

Remember how you worked out word problems of addition of mixed **fractions**. You will use the same method except that the symbol will change to subtraction.

In this lesson, you will read the sentence, interpret then work out the problem.

### Step 1: Activity

- Get circular cutouts.



- Cut one of them into 4 equal parts.
- Take away 3 wholes and  $\frac{1}{4}$
- How many wholes and quarters remain?
- Therefore you will remain with 2 wholes and  $\frac{3}{4}$

### Step 2

Study the example below.

1. Juma had  $3\frac{1}{2}$  water melons, he gave out  $2\frac{1}{4}$

What fraction remained?

$$3\frac{1}{2} - 2\frac{1}{4} = \frac{7}{2} - \frac{9}{4} \quad \text{LCD} = 4$$

find the LCD of  $\frac{7}{2}$  and  $\frac{9}{4}$

$M_2 = (2, 4, 6, 8, \dots)$

$M_4 = (4, 8, 12, \dots)$       LCD = 4

$$= \frac{(\frac{7}{2} \times 4) - (\frac{9}{4} \times 4)}{4}$$

$$= \frac{14 - 9}{4}$$

$$= \frac{5}{4}$$

$$= 1\frac{1}{4}$$

$$4 \div 2 = 2$$

$$7 \times 2 = 14$$

$$4 \div 4 = 1$$

$$9 \times 1 = 9$$

Method 2

$$(3 - 2) + \frac{1}{2} - \frac{1}{4}$$

LCD = 4

$$\frac{1 + \frac{1}{2} \times 4 - \frac{1}{4} \times 4}{4}$$

$$\frac{1 + (2 - 1)}{4}$$

$$= 1\frac{1}{4}$$

**Exercise**

You can now do this exercise.

1. At a school, pupils use  $4\frac{1}{2}$  bags of beans while other workers use  $2\frac{1}{3}$ . How many more bags do pupils use?
2. Subtract  $1\frac{1}{2}$  from  $3\frac{1}{4}$
3. Musoke had  $2\frac{3}{4}$  cakes and ate  $1\frac{1}{2}$  cakes. What fraction of the cake remained?
4. On a wall  $3\frac{2}{3}$  was painted. When it rained,  $1\frac{1}{9}$  of the paint was washed away. What fraction of **the paint** remained on the wall?
5. Subtract  $7\frac{1}{3}$  from  $10\frac{1}{2}$

**Lesson 8: Multiplying a whole number by a fraction.****In this lesson, you will:**

- Multiply a whole number by a fraction.
- Solve word problems involving multiplication of whole numbers by a fraction.

**You will need:**

- An exercise book and a pen.
- A ruler and a pencil.

**Introduction:**

In the previous lessons of multiplication, you noticed that multiplication is repeated addition. In this lesson, you are going to multiply a whole number by a fraction. The whole number will tell you how many times the fraction has been added.

When you multiply 4 by  $\frac{1}{3}$ . This means

$$\begin{aligned} 4 \times \frac{1}{3} &= \frac{1}{3} + \frac{1}{3} + \frac{1}{3} + \frac{1}{3} \\ &= \frac{4}{3} \\ &= 1\frac{1}{3} \end{aligned}$$

**Step 1**

**Activity**

- Draw a number line and label it like the one below.

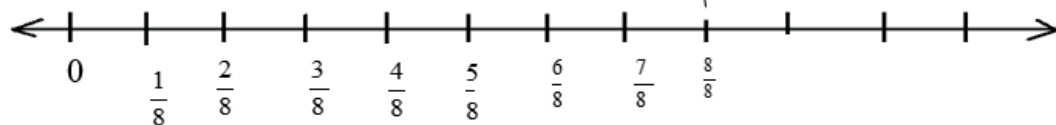

- Make 5 jumps of  $\frac{1}{8}$  each.
- Where have you stopped?
- You will notice that you have stopped at  $\frac{5}{8}$ , this means  $5 \times \frac{1}{8} = \frac{5}{8}$

**Step 2**

**Now study the examples**

**Example 1**

Work out:

$$7 \times \frac{1}{10}$$

$$7 \times \frac{1}{10} = \left(\frac{7}{1} \times \frac{1}{10}\right)$$

$$= \frac{7 \times 1}{1 \times 10}$$

$$= \frac{7}{10}$$

**Example 2**

Work out :

$$6 \times \frac{2}{5}$$

$$6 \times \frac{2}{5} = \left(\frac{6}{1} \times \frac{2}{5}\right)$$

$$= \frac{12}{5}$$

$$= 2\frac{2}{5}$$

**Exercise**

Work out.

1.  $6 \times \frac{1}{3}$

2.  $4 \times \frac{1}{2}$

3.  $6 \times \frac{2}{9}$

4.  $12 \times \frac{3}{11}$

5.  $10 \times \frac{3}{7}$

6.  $7 \times \frac{2}{13}$

7.  $4 \times \frac{1}{5}$

8.  $16 \times \frac{3}{4}$

## Lesson 9: Multiplying proper fractions by proper fractions.

### In this lesson, you will:

- Multiply proper fractions by proper fractions.
- Reduce fractions to the lowest.

### You will need:

- Rectangular sheets of paper.
- A ruler and a pencil.
- An exercise book and a pen.

### Introduction:

In primary four, you learnt how to multiply a proper fraction by a whole number. In this lesson, you are going to multiply a proper fraction by a proper fraction.

Multiplication of fractions is important because it helps you to know what part of a fraction you need, for example, when baking a cake, what fraction of baking powder, milk, wheat flour and sugar you need.

### Step 1: Activity

- Get a rectangular sheet of paper. Fold it into equal parts and shade a half.
- Fold the paper again vertically into three equal parts and shade  $\frac{1}{3}$ .
- What fraction of the shaded region is shaded twice?



$$\frac{1}{3} \text{ of } \frac{1}{2} = \frac{1}{6}$$

### Step 2

Now study the examples below

#### Example 1

Work out  $\frac{2}{7} \times \frac{1}{4}$

Reduce to the lowest

$$\frac{2}{7} \times \frac{1}{4} = \frac{2 \times 1}{7 \times 4}$$

$$= \frac{2}{28}$$

$$= \frac{1}{14}$$

Multiply numerators

Multiply the denominators

**Example 2**  
 Work out  $\frac{3}{4} \times \frac{1}{2} \times \frac{4}{9}$

$$\frac{3}{4} \times \frac{1}{2} \times \frac{4}{9} = \frac{3 \times 1 \times 4}{4 \times 2 \times 9} = \frac{1}{6}$$

Multiply numerators

Multiply the denominators

**Exercise**

Work out:

1.  $\frac{4}{5} \times \frac{1}{3}$

2.  $\frac{1}{3} \times \frac{3}{8}$

3.  $\frac{1}{3} \times \frac{1}{4}$

4.  $\frac{7}{8} \times \frac{1}{14}$

5.  $\frac{1}{2} \times \frac{2}{4} \times \frac{3}{4}$

6.  $\frac{1}{4} \times \frac{2}{9}$

**Lesson 10: Reciprocals.**

**In this lesson, you will:**

- Find the reciprocal of numbers.

**You will need:**

- Sheet of paper.
- A ruler and a pencil.
- An exercise book and a pen.

**Introduction:**

Division is the opposite of multiplication for example you can find the answer to  $8 \div 2$  by asking yourself ‘what number when multiplied by 2 gives 8?’

In other words, you should find the missing factor in  $p \times 2 = 8$ , which is 4.

In this lesson, you are going to find the reciprocal. In order to find reciprocal, you need to ask this question, what number do I need to multiply by the given number to get 1?

The reciprocal of 2 is  $\frac{1}{2}$  because  $2 \times \frac{1}{2}$  is 1.

**Step 1****Activity**

- Get a sheet of paper, a ruler and a pencil.
- Form cards and write the fractions on each.

A	B	C	D	E	F
$8 + \frac{1}{8}$	$8 \times \frac{1}{8}$	$4 + \frac{1}{4}$	$4 \times \frac{1}{4}$	$2 + \frac{1}{2}$	$2 \times \frac{1}{2}$

- Which cards have the same answer?
- Therefore cards B, D and F have the same answer 1.

**Step 2**

Now study the examples below.

**Example 1**

What is the reciprocal of  $\frac{1}{4}$ ?

Let the reciprocal be k.

$$k \times \frac{1}{4} = 1$$

$$k \times \frac{1}{\cancel{4}} \times 4 = \cancel{4} \times 4$$

$$= 4$$

The reciprocal of  $\frac{1}{4}$  is 4

**Example 2.**

Find the reciprocal of  $2\frac{1}{2}$

Let the reciprocal be w.

$$w \times 2\frac{1}{2} = 1$$

$$w \times \frac{5}{2} = 1$$

$$\frac{5}{2} w \times 2 = \cancel{2}$$

$$\frac{5}{5} w = \frac{2}{5}$$

$$w = \frac{2}{5}$$

The reciprocal of  $2\frac{1}{2}$  is  $\frac{2}{5}$

**Exercise**

Now try this exercise.

A 1)  $\frac{2}{1} \times \square = 1$       2)  $\frac{3}{10} \times \square = 1$

3)  $\frac{4}{5} \times \square = 1$       4)  $\frac{7}{5} \times \square = 1$

B. Find the reciprocal of:

1)  $\frac{3}{2}$       2) 4      3)  $\frac{3}{8}$       4) 5      5)  $\frac{3}{2}$

**Lesson 11: Dividing whole numbers by fractions.**

**In this lesson, you will:**

- Divide a whole number by a fraction.
- Solve word problems involving division of whole numbers by fractions.

**You will need:**

- Sheets of paper.
- An exercise book and a pen
- A ruler and a pencil

**Introduction:**

In the previous lesson, you learnt how to find the reciprocal of numbers.

It is this very idea that is going to help you divide a whole number by a fraction.

To divide a whole number by a fraction, you multiply by the reciprocal of a divisor.

**Step 1: Activity**

- Get 3 strips of paper.
- Cut them into quarters.
- Count the number of quarters got from the 3 strips of paper.
- How many quarters are in 3?
- You will notice that there are 12 quarters.



**Step 2****Now study the examples below****Example 1**

Work out:

$$7 \div \frac{1}{2}$$

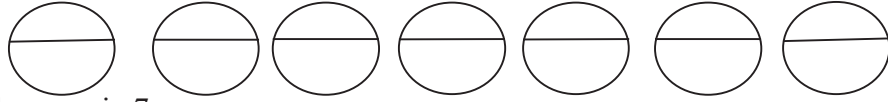

How many halves are in 7

$$7 \div \frac{1}{2} = 7 \times \frac{2}{1} \\ = 14$$

Multiply by the reciprocal

**Example 2**

Namukwaya poured 15 litres of water into quarter litre bottles.

How many bottles did she fill?

$$15 \div \frac{1}{4} = 15 \times \frac{4}{1}$$

$$= 60$$

Therefore she filled 60 bottles.

Multiply by reciprocal

**Exercise**

Work out:

1.  $7 \div \frac{1}{2}$

4)  $36 \div \frac{2}{5}$

2.  $9 \div \frac{2}{3}$

5)  $24 \div \frac{1}{3}$

3.  $10 \div \frac{1}{4}$

6. My mother packed 18kg of sugar into half kg packets. How many packets did she make?

7. Rajab poured 10 litres of honey into a third litre containers. How many containers did he fill?

8. How many quarters litre bottles can be filled from 20 litres?

**Lesson 12: Dividing a fraction by a whole number.****In this lesson, you will:**

- Divide a fraction by a fraction.
- Solve simple word problems involving division of fractions.

**You will need:**

- Rectangular pieces of paper.
- A pencil and a ruler.
- An exercise book and a pen. A ruler and a pencil

**Introduction:**

In the previous lesson you learned about reciprocal. In this lesson, the idea of a reciprocal is repeated because when you divide a fraction by a whole number, you multiply by the reciprocal of its divisor.

In the next step, you are going to use a rectangular piece of paper to practically see how a fraction can be divided by a whole number.

**Step 1**

**Activity**

- Fold a rectangular piece of paper into halves.
- Shade one of the halves and fold it again into halves.
- Again fold it into halves.
- Now unfold the paper.
- You will notice that half the paper is divided into 4 equal parts. Each part is equal to  $\frac{1}{8}$  of the whole sheet.

$$\begin{aligned} \text{This shows that } \frac{1}{2} \div 4 &= \frac{1}{2} \times \frac{1}{4} \\ &= \frac{1}{8} \end{aligned}$$

**Step 2: Now study the examples**

**Example 1**

Work out:  $\frac{1}{3} \div 4$

$$\begin{aligned} \frac{1}{3} \div \frac{4}{1} &= \frac{1}{3} \times \frac{1}{4} \\ &= \frac{1 \times 1}{3 \times 4} \\ &= \frac{1}{12} \end{aligned}$$

Multiply by the reciprocal.

**Example 2**

Adeke was given  $\frac{1}{2}$  of sugarcane and shared it equally among 3 brothers. What fraction did each get?

$$\frac{1}{2} \div \frac{3}{1} = \frac{1}{2} \times \frac{1}{3}$$

$$= \frac{1 \times 1}{2 \times 3}$$

$$= \frac{1}{6}$$

Each got  $\frac{1}{6}$

Multiply by reciprocal

**Exercise**

Work out:

1.  $\frac{1}{4} \div 2$

3.  $\frac{3}{4} \div 8$

2.  $\frac{2}{5} \div 10$

4.  $\frac{1}{2} \div 6$

5. A boy shared  $\frac{1}{2}$  of an orange equally among 4 children. What fraction did each child get?

6. Divide  $\frac{1}{4}$  of a water melon equally among 3 friends. What fraction does each get?

7. Share  $\frac{2}{3}$  of a sugarcane equally between 2 girls. What fraction does each get?

**Lesson 13: Dividing a fraction by a fraction.****In this lesson, you will:**

- Divide a fraction by a fraction.
- Solve word problems involving dividing a fraction by a fraction.

**You will need:**

- An exercise book and a pen.
- A ruler and a pencil.
- Sheets of a paper.

**Introduction:**

In the previous lesson you **learnt how** to divide a fraction by a whole number. You noticed how the idea of reciprocal was used to get the quotient. In this lesson, you are going to learn how to divide a fraction by a fraction. It is easier to do this practically before you work out by calculation.

**Step 1: Activity**

- Draw a line CD similar to the one below:

- Mark  $\frac{1}{4}$ ,  $\frac{1}{2}$  and  $1 - \frac{1}{4}$  points.
- Also mark the points between:
  - i) 0 and  $\frac{1}{2}$
  - ii)  $\frac{1}{4}$  and  $\frac{1}{2}$
  - iii)  $\frac{1}{2}$  and  $\frac{3}{4}$
- Make a small strip of paper that is half of line CD.
- Find the number of half strips of paper that can be obtained in a length of  $\frac{3}{4}$  of a line CD.
- Work out :  $\frac{3}{4} \div \frac{1}{2}$

**Step 2**

Now study the examples

<p><b>Example 1</b></p> <p>Work out: <math>\frac{1}{4} \div \frac{1}{2}</math></p> $\frac{1}{4} \div \frac{1}{2} = \frac{1}{4} \times \frac{2}{1}$ $= \frac{2 \times 1}{4 \times 1}$ $= \frac{2}{4} = \frac{1}{2}$	<p>Multiply the reciprocal by the divisor.</p>	<p><b>Example 2</b></p> <p>How many <math>\frac{3}{5}</math> litres of juice are in <math>\frac{2}{3}</math> litres of juice?</p> $\frac{3}{5} \div \frac{2}{3} = \frac{3}{5} \times \frac{3}{2}$ $= \frac{3 \times 3}{5 \times 2}$ $= \frac{9}{10}$
--	--	--

**Exercise**

1.  $\frac{1}{5} \div \frac{1}{3}$

2.  $\frac{2}{7} \div \frac{1}{14}$

5. Divide  $\frac{1}{9}$  by  $\frac{1}{6}$

6. How many  $\frac{1}{4}$  litres of water are in a  $\frac{1}{2}$  litre of water?

7. Find how many  $\frac{1}{2}$  kg packets of sugar can be made from  $\frac{3}{4}$  kg of sugar?

3.  $\frac{8}{9} \div \frac{4}{5}$

4.  $\frac{2}{3} \div \frac{4}{9}$

## Term Two

### TOPIC: Fractions

#### Lesson 1: Identify the decimal fractions

In this lesson you will:

1. Find the shaded fraction.
2. Identify the shaded decimals.

**You will need:** a pencil, a pen, a paper, and a book

#### Introduction

In the previous classes (P.4 – p.1), you learnt about fractions where a bar is used to separate the numerator from the denominator. In today’s lesson, you are going to learn about decimal fractions where a whole number is separated by a dot.

You will notice that when you write decimal fractions you use a dot, called a decimal point, to separate the whole number part from the part less than one. The places to the right of the decimal point are called decimal places. Numbers that are written with a decimal point are called decimal fractions. This topic will help you to develop effective communication skills which will enable you to describe parts of a whole such as parts of a sack of posho among others.

To understand this better try the activity below

#### Step 1

Get a piece of paper and divide it into 10 equal parts.

Shade 2 parts out of 10.



Write the shaded part as a fraction. The shaded part as a fraction is  $\frac{2}{10}$ .

Now divide the numerator by the denominator. You will notice that  $2 \div 10$  is as shown below

$$\begin{array}{r}
 \phantom{2} \overline{) 2} \\
 \underline{-0} \\
 20 \\
 \underline{-20} \\
 00
 \end{array}$$

$2 \times 10 = 10$

$2 \div 10 = 0$  ones. Write a point after 0 and then we add a 0 after 2 to make it 20  
 $20 \div 10 = 2$

Therefore  $\frac{2}{10}$  as a decimal fraction is 0.2

**Step 2:** Look at these examples:

**Example 1.** Name the shaded decimal.

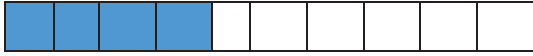

You can see that 4 parts have been shaded out of 10.

This means that the shaded fraction is  $\frac{4}{10}$

Now  $\frac{4}{10}$  in decimal is worked out as shown below.

$$\begin{array}{r}
 0.4 \\
 10 \overline{) 4} \\
 \underline{-0} \phantom{0} \\
 40 \\
 \underline{-40} \\
 00
 \end{array}
 \quad
 \begin{array}{l}
 4 \div 10 = 0 \text{ ones. Write a point after 0 and then we add a 0 to 4 to make it } 40 \\
 40 \div 10 = 4
 \end{array}$$

Therefore the shaded decimal is 0.4

**Example 2.** Name the shaded decimal

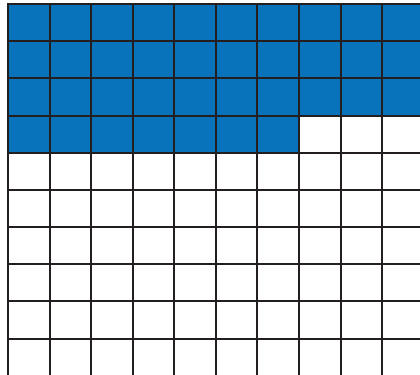

You can see that 37 parts have been shaded out of 100

This means that the shaded fraction is  $\frac{37}{100}$

Now we change  $\frac{37}{100}$  to a decimal using long division as shown below

$$\begin{array}{r}
 0.37 \\
 100 \overline{) 37} \\
 \underline{-00} \phantom{0} \\
 370 \\
 \underline{-300} \\
 700 \\
 \underline{-700} \\
 000
 \end{array}
 \quad
 \begin{array}{l}
 37 \div 100 = 0 \text{ ones. Write a point after 0 and then we add 0 after 37 to make it } 370 \\
 370 \div 100 = 3 \text{ remainder } 70. \text{ Then we add 0 after 70 to make it } 700. \\
 700 \div 100 = 7
 \end{array}$$

Therefore the shaded decimal is 0.37

**Example 3:** Change  $\frac{7}{10}$  to a decimal fraction

$0 \times 10 = 0$	$\begin{array}{r} 0.7 \\ 10 \overline{) 7} \\ \underline{-0} \phantom{0} \\ 70 \\ \underline{-70} \\ 00 \end{array}$	$7 \div 10 = 0$ ones. Write a point after 0 and then we add a 0 after 7 to make it 70
$7 \times 10 = 70$	$\begin{array}{r} 70 \\ \underline{-70} \\ 00 \end{array}$	$70 \div 10 = 7$

Therefore  $\frac{7}{10}$  as a decimal fraction is 0.7

### Step 3

#### Exercise

Identify the shaded decimals.

1.

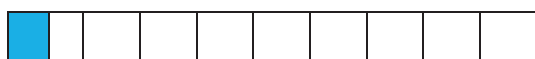

2.



3.

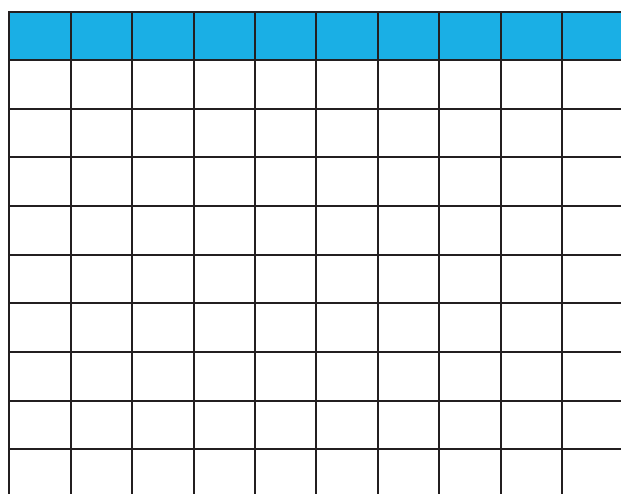

4. Change  $\frac{58}{100}$  to a decimal fraction

5. Change  $\frac{9}{10}$  to a decimal fraction.



**Lesson 2: Place value and value of decimals up to hundredths.****In this lesson you will:**

1. Identify and name the place values of decimals up to hundredths.
2. Read and write the values of digits in decimals.

**You will need:** a pen, a ruler, a pencil, a book

**Introduction**

Decimals have place values different from those of whole numbers. With whole numbers the place values start from: ones and go on. Now decimal place values start from tenths, hundredths and so on. For our class, we shall stop at hundredths. Place values help us to tell the value of each digit in a number.

**Step 1.**

Get a sheet of paper, write ones, separate with a point and write tenths, hundredths. Write 0.23 in the right places. You will notice that the number will appear like this below. Ones, tenths, hundredths.

Ones	.	Tenths	Hundredths
0	.	2	3

Try this with different numbers.

**Step 2****Look at the following examples:**

**Example 1.** Write the place value of each digit in the number 1.98

The place value of each digit can be identified in the table as shown below.

Ones	.	Tenths	Hundredths
1	.	9	8

From the

table we can say that:

The place value of 1 is ones.

The place value of 9 is tenths.

The place value of 8 is hundredths.

**Example 2.** Write the place value 5 in 0.25

Using the table, the place value of 5 can be identified as indicated below.

Ones	.	Tenths	Hundredths
0	.	2	5

The place value of 5 is hundredths.

**Example 3.** What is the place value of 7 in the number 64.72?

Tens	ones	.	Tenths	Hundredths
6	4	.	7	2

The place value of 7 is tenths.

**Example 4.** Find the value of each digit in the number 98.24.

Note:

a) Tenths =  $\frac{1}{10}$

b) Hundredths =  $\frac{1}{100}$

First award the place value of each digit

Tens	Ones	.	Tenths	Hundredths
9	8	.	2	4

Remember to find the value, multiply the digit by its numerical place value

Value of 9

$9 \times 10 = 90$ . The value of 9 is 90.

Value of 8

$8 \times 1 = 8$ . The value of 8 is 8.

Value of 2

$2 \times \frac{1}{10} = \frac{2}{10}$

Now  $2 \div 10$  is worked out as shown below

$$\begin{array}{r}
 0.2 \\
 10 \overline{) 2} \\
 \underline{0 \times 10 = 0} \phantom{0} \\
 -0 \phantom{0} \\
 \underline{2 \times 10 = 20} \phantom{0} \\
 -20 \\
 \underline{\phantom{2} 0} \\
 00
 \end{array}$$

$2 \div 10 = 0$  ones. Write a point after 0. Then add a 0 after 2 to make it 20.

$20 \div 10 = 2$

Therefore the value of 2 is 0.2

Value of 4

$4 \times \frac{1}{100} = \frac{4}{100}$

Now  $4 \div 100$  is worked as shown below

$$\begin{array}{r}
 0.04 \\
 \hline
 100 \overline{) 4} \\
 0 \times 100 = 0 \quad \underline{-0} \\
 40 \\
 0 \times 100 = 0 \quad \underline{-00} \\
 400 \\
 3 \times 100 = 300 \quad \underline{-400} \\
 000
 \end{array}$$

$4 \div 100 = 0$  ones. Write a decimal point after 0 and then add a 0 after 4 so that it becomes 40.

$40 \div 100 = 0$ . Add a 0 after 40 so that it becomes 400.

Now  $400 \div 100 = 4$

Therefore the value of 4 is 0.04

### Exercise

- A. What is the place value of each digit in the following numbers?  
 1) 0.5    2) 0.73    3) 71.86
- B. What is the place value of 6 in each of the following numbers?  
 1) 0.68    2) 0.96    3) 5.61
- C. Find the value of each digit in the numbers below:  
 a) 8.3    b) 47.6    c) 298.51    d) 0.78.

### Lesson 3: Writing decimals in words and vice versa.

- In this lesson you will:**
1. Write decimals in words
  2. You will read decimals
  3. Write decimals in figures

**You will need:** a pencil, a pen, a book and a ruler

#### Introduction

To write decimals in words the following must be noted:

1. Write the place value of each digit
2. Read the number formed before the decimal point separately from the number formed after the decimal point.
3. Read the decimal point as single digits "and"
4. Read the rest of the digits as a whole number and say the place value of the last digit. This topic will help you to develop effective communications skills which will enable **you** to describe parts of a whole among others.

**Step 1**

Use the place value chart shown below and write the place value of each digit.

Place value	Ones	.	-----	-----
Number	8	.	5	7

The expected answers are shown in the table below

Place value	Ones	.	Tenths	Hundredths
Number	8	.	5	7

**Step 2**

Look at the following examples:

**Example 1.** Write 0.5 in words

First write the place value of each digit as shown below

Ones	.	Tenths
0	.	5

The number in words is; Five tenths

People often read decimals in a shorter way. You can read 0.5 as: zero point five

**Example 2.** Write 0.72 in words

Ones	.	Tenths	Hundredths
0	.	7	2

0.72 is read as; seventy two hundredths

Or

Zero point seven two

**Example 3.** Write 3.7 in words

Ones	.	Tenths
3	.	7

3.7 is read as; Three and seven tenths

Or

Three point seven

**Example 4.** Write 25.84 in words

Tens	Ones	.	Tenths	Hundredths
2	5	.	8	4

25.84 is read as; Twenty five and eighty four hundredths

Or

Twenty five point eight four.

**Example 5.** Write five tenths in figures

Note:

Decimals are written and read according to the digits in their place values. Secondly a number which ends in the place value of tenths has one decimal place and a number which ends in the place value of hundredths has two decimal places.

Draw a place value table and position digits according to their place values as shown below

Ones	.	Tenths
0	.	5

Five tenths = 0.5

Or

Five tenths means 5 out of 10, which is written as  $\frac{5}{10}$  in fraction form

Now change  $\frac{5}{10}$  to a decimal

$$\begin{array}{r}
 0.5 \\
 \underline{10 \overline{) 5}} \\
 -0 \\
 \hline
 50 \\
 \underline{-50} \\
 00
 \end{array}$$

$5 \div 10 = 0$  ones. Write a point after 0 and then add a 0 after 5 to make it 50

$$50 \div 10 = 5$$

**Example 6.** Write seven and nine tenths in figures

Note that the word “and” in this case represents the decimal point. Secondly it separates the whole number from the decimal number. The place value table will be of help as shown below

Ones	.	Tenths
7	.	9

Seven and nine tenths = 7.9

**Example 7.** Write twenty four and seventy three hundredths in figures

Separate the whole numbers from decimal numbers as shown in the table below.

Remember the word “and” stands for the decimal point

Tens	Ones	.	Tenths	Hundredths
2	4	.	7	3

Twenty four and seventy three hundredths = 24.73

### Step 3

#### Exercise

A. Write each of the following in words

- 1) 0.4   2) 0.9   3) 2.8   4) 9.2   5) 0.26   6) 0.43   7) 85.4   8) 32.92

B. Write the following in figures

1. Three tenths
2. Six tenths
3. Eight and five tenths
4. Forty six and two tenths

### Lesson 4: Comparing decimals using a number line

In this lesson you will:

1. Compare decimals using a number line
2. Read decimals on a number line
3. Arrange decimals in ascending order or descending order

**You will need:** a pen, a pencil, a book.

#### Introduction.

Note that a decimal to the right of the other is greater than the decimal on its left on the number line.

We can therefore say that decimals become bigger as you move **the** right of the number line or decimals become smaller as you move to the left of the number line. We compare numbers to see if they are the same or to see which is greater or less. This topic will help you to compare decimal amounts when building or cooking.

### Step 1

Look at this number line below with units between 0 and 1



Draw a star at the following numbers on the number line: 0.8, 0.1, and 0.4. Now arrange the numbers starting with the smallest.

Well the expected answer is right here:

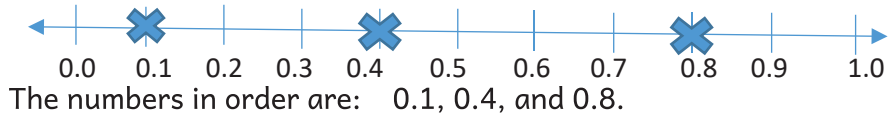

## Step 2

Now look at the following examples

**Example 1.** Use the symbols  $<$  or  $>$  to compare A and B

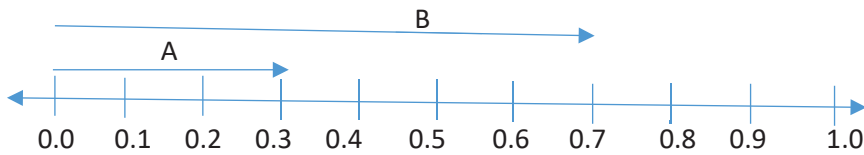

**Note.**

$<$ , is a less than sign which means something smaller

$>$ , is a greater than sign which means something bigger

Arrow A = 0.3 and arrow B = 0.7

Therefore  $0.3 < 0.7$  or  $0.7 > 0.3$ .

**Example 2.** Use the symbols  $<$  or  $>$  to compare P and Q

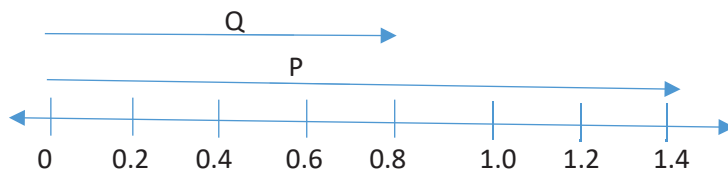

Arrow P = 1.4 and arrow Q = 0.8

Therefore  $1.4 > 0.8$  or  $0.8 < 1.4$

**Example 3.** Arrange the following from the lowest to the highest: 0.9, 0.1, and 0.3

We show our working on the number line as indicated below



The order from the lowest to highest is: 0.1, 0.3, and 0.9

**Example 4.** Arrange 0.04, 0.09, and 0.06 from the highest to the lowest.



The order from the highest to the lowest is : 0.09, 0.06, 0.04.

**Example 5.** Arrange the following starting from the lowest to the highest: 0.47, 0.5, 9.8, 0.12.

**We can do this number without using a number line. The question is, how can it be done?**

1. Change the decimals to fractions
2. Identify the highest denominator
3. Multiply each fraction by the highest denominator and write the answer got in each working.
4. Compare the values and then arrange

Here is the working, study it carefully

$$0.47 = \frac{47}{100} \quad , \quad 0.5 = \frac{5}{10} \quad , \quad 9.8 = \frac{98}{10} \quad , \quad 0.12 = \frac{12}{100}$$

The highest denominator is 100. Multiply each fraction by 100 as shown below

$$\frac{47}{100} \times 100 = 47 \quad , \quad \frac{5}{10} \times 100 = 50 \quad , \quad \frac{98}{10} \times 100 = 980 \quad , \quad \frac{12}{100} \times 100 = 12$$

Compare the answers with the decimals and then arrange accordingly

The order from the highest to the lowest is: 9.8, 0.5, 0.47, and 0.12

**Note.**

Ascending order is the arranging of numbers from the smallest to the biggest and descending order is the arranging of numbers from the biggest to the smallest.

**Step 3.**

**Exercise.**

Use the symbols  $<$  or  $>$  to compare the following.

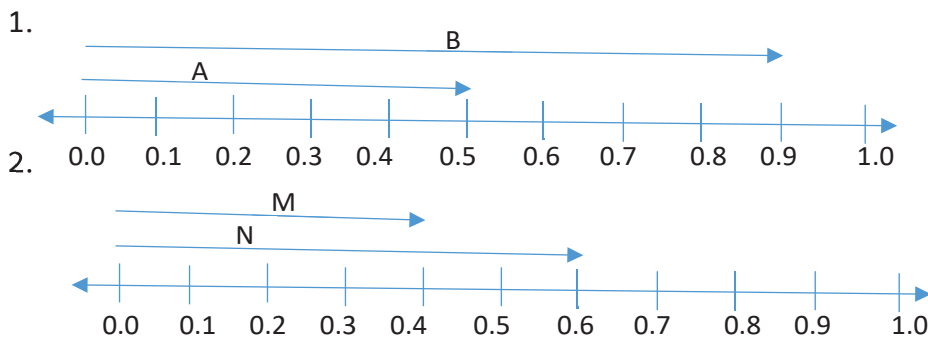



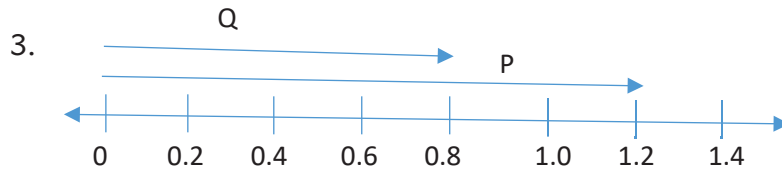

A. Arrange the following from lowest to highest

1. 0.8, 0.1, 0.6

3. 0.04, 0.07, 0.02

2. 0.3, 0.9, 0.4, 0.7

4. 0.08, 0.06, 0.03

B. Arrange the following from highest to lowest

1. 0.1, 0.9, 0.3

3. 0.6, 0.98, 0.24, 0.8

2. 0.02, 0.08, 0.04, 0.05

4. 1.2, 4.7, 0.53, 0.4

### Lesson 5: Changing fractions to decimals and vice versa

In this lesson you will: 1. Change fractions to decimals.

2. Change decimals to fractions.

You will need: a pen, a pencil, a book

#### Introduction

You have already seen normal fractions and decimal fractions. To change a fraction to a decimal, divide the numerator by the denominator until there is no remainder. You can use the knowledge of fractions to share things fairly, for example sharing one pancake by 4 children.

#### Step 1

Make two strips and divide each of them into 10 equal parts.

Write fractions from  $\frac{1}{10}$  to  $\frac{10}{10}$  on one of the strips and 0.1 to 1.0 on the other as shown below

0.1	0.2	0.3	0.4	0.5	0.6	0.7	0.8	0.9	1.0
-----	-----	-----	-----	-----	-----	-----	-----	-----	-----

$\frac{1}{10}$	$\frac{2}{10}$	$\frac{3}{10}$	$\frac{4}{10}$	$\frac{5}{10}$	$\frac{6}{10}$	$\frac{7}{10}$	$\frac{8}{10}$	$\frac{9}{10}$	$\frac{10}{10}$
----------------	----------------	----------------	----------------	----------------	----------------	----------------	----------------	----------------	-----------------

a) Write a fraction equivalent to 0.7

The expected answer is  $\frac{7}{10}$

b) Write a decimal equivalent to  $\frac{8}{10}$ .

The expected answer is 0.8

**Step 2**

Now look at the following examples

**Example 1.** Change 0.5 to a fraction in its lowest form.

The place value of the last digit is tenths, tenths means 1 out of 10 which is written as  $\frac{1}{10}$

Therefore 0.5 as a fraction is  $\frac{5}{10}$

Reduce  $\frac{5}{10}$  to the lowest term. This is done by dividing both the numerator and denominator by a common factor.

$$\frac{5 \div 5}{10 \div 5} = \frac{1}{2}$$

**Example 2.** Change 0.24 to a fraction in its lowest term.

The place value of the last digit is hundredths, hundredths means 1 out of 100 which is written as  $\frac{1}{100}$

Therefore 0.24 as a fraction is  $\frac{24}{100}$

Reduce  $\frac{24}{100}$  to the lowest term

$$\frac{24 \div 2}{100 \div 2} = \frac{12}{50} \qquad \frac{12 \div 2}{50 \div 2} = \frac{6}{25}$$

**Example 3.** Change  $\frac{7}{10}$  to a decimal

$0.7$	
$\overline{) 7}$	$7 \div 10 = 0$ ones. Then add 0 after 7 to make it 70
$\underline{-0}$	
$70$	$70 \div 10 = 7$
$7 \times 10 = 70$	
$\underline{-70}$	
$00$	

Therefore  $\frac{7}{10}$  as a decimal is 0.7.

**Example 4.** Change  $\frac{4}{5}$  to a decimal

$$\begin{array}{r}
 0.8 \\
 \hline
 5 \overline{) 4} \quad 4 \div 5 = 0 \text{ ones. Then add a 0 after 4 to make it } 40 \\
 \underline{-0} \\
 40 \quad 40 \div 5 = 8 \\
 \underline{-40} \\
 00
 \end{array}$$

**Exercise**

A. Change the following decimals to fractions

1. 0.2    2. 0.8    3. 0.22    4. 0.48    5. 0.98

B. Change the following fractions to decimals

1.  $\frac{5}{10}$     2.  $\frac{3}{5}$     3.  $\frac{49}{100}$     4.  $\frac{1}{4}$     5.  $\frac{1}{2}$

**Lesson 6: Adding decimals****In this lesson you will:** 1. Add decimals

2. Arrange decimal fractions according to their place values.

3. Solve word problems.

4. Read and interpret word problems.

**You will need:** a pen, a pencil, a book**Introduction**

In addition of decimals, the following need to be noted:

1. Arrange the decimals according to their place values and then add normally.
2. Make sure that the decimal points are under the same line from top to the answer.

This topic will enable you to develop problem solving skills which will help you to share decimals fairly.

**Step 1**

Study the illustration below

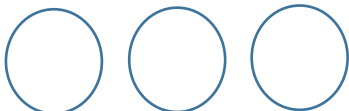
 $+ \frac{1}{10} .$  How many wholes and tenths are there altogether?

Well the expected answer is  $3\frac{1}{10}$ .

## Step 2

Now look at the following examples

1. Work out:  $43.7 + 25.1$ .

Arrange the numbers vertically according to their place values

$$\begin{array}{r} 43.7 \\ + 25.1 \\ \hline 68.8 \end{array}$$

2. Work out :  $53.24 + 4.8$

Arrange the numbers vertically according to their place values

$$\begin{array}{r} 53.24 \\ + 4.80 \\ \hline 58.04 \end{array}$$

3. Work out  $4 + 0.25$

Arrange the numbers vertically according to their place values

Change 4 to a decimal by adding a decimal point and 2 zeros as shown below

$$\begin{array}{r} 4.00 \\ + 0.25 \\ \hline 4.25 \end{array}$$

4. What is the sum of 0.53 and 7.45

Note that the word sum means addition.

Arrange the numbers according to their place value like we did earlier.

$$\begin{array}{r} 0.53 \\ + 7.45 \\ \hline 7.98 \end{array}$$

5. Adeke prepared 4.3 litres of juice on Saturday and 8.67 litres of juice on Sunday.  
How many litres of juice did she prepare altogether?

On Saturday .....4. 3 0 litres Add a 0 after 3 on 4.3 to make the number of

On Sunday .....+ 8. 67 litres decimal places the same.

$$\begin{array}{r} 4.30 \\ + 8.67 \\ \hline 12.97 \end{array}$$

Altogether she prepared 12.97 litres Of juice.

### Exercise

Work out the following:

1.  $7 + 0.4$    2.  $24.7 + 14.2$    3.  $82.6 + 7.2$    4.  $67.14 + 0.28$    5.  $0.12 + 0.6$
6. Odong got 6.72 litres of milk from his cow in the morning and 5.28 litres in the evening. How much milk did he get that day?
7. A hen weighs 2.56 kilograms and a cock weighs 3.21 kilograms. Find the total weight of the two birds

### Lesson 7: Subtraction of decimals

In this lesson, you will:

1. Subtract decimals
2. Solve word problems involving subtraction of decimals.

**You will need:** a pencil, a pen, a book.

#### Introduction

In the previous lesson, you learnt about addition of decimals. In today's lesson, you are going to learn how to subtract decimals. This topic will help you to develop problem **solving** skills.

**Step 1:** Work out:  $6.4 - 2.1$ .

Well, the expected answer is 4.3

#### Step 2

Look at the following examples:

Note

- When subtracting decimals, first arrange the digits according to their place values, and then carry out the subtraction process.

- Always arrange the numbers vertically.

1. Work out:  $0.6 - 0.4$ .

$$\begin{array}{r} 0.6 \\ -0.4 \\ \hline 0.2 \end{array}$$

2. Work out:  $17.3 - 5.12$ .

$$\begin{array}{r} 17.30 \\ -5.12 \\ \hline 12.18 \end{array}$$

### Exercise

Work out the following:

- a)  $59.7 - 4.2$       b)  $18.7 - 4.05$
- c) Subtract 7.5 from 10.12
- d) Akullo's baby weighs 8.7kg and Naigaga's baby weighs 7.93kg.
- i) Whose baby is heavier?
- ii) By how much?

### TOPIC: LINES, ANGLES AND GEOMETRIC FIGURES

#### Lesson 1: Parallel lines

**In this lesson, you will:**

1. Identify parallel lines.
2. Draw parallel lines.

You will need: a sharp pencil, a pen, a book, a ruler, sticks, a set square

#### Introduction

Parallel lines are lines which do not meet because they have the same distance apart (away from each other) at every point. The pair of lines shown below shows an example of parallel lines.

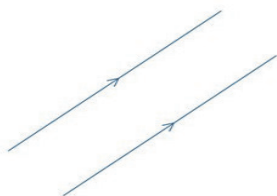

Parallel lines are useful in understanding the relationship between paths of objects and sides of various shapes. For example, squares, rectangles and parallelograms have sides

across from each other that are parallel. The knowledge of parallel lines helps us to plant our crops in straight rows.

### Step 1

The symbol for parallel is a pair of vertical lines. If line segment  $\overline{AB}$  is parallel to line segment  $\overline{DC}$  (DC), we write it in short form as  $\overline{AB} \parallel \overline{DC}$ .

How do you tell that some lines are parallel?

To show that some lines are parallel we use signs (arrows) as shown below

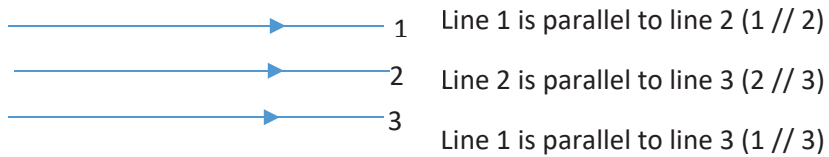

### Step 2

Look at the following examples

**Example 1** Draw 4 parallel lines in your book.

Well, you may have drawn lines similar to the ones below:



### Example 2

Using a ruler, a set square and a pencil only, draw a line parallel to line segment AB in the space provided.

A ————— B

Draw line segment AB as shown below

A ————— B

(a) Place the set square along the line AB as shown below

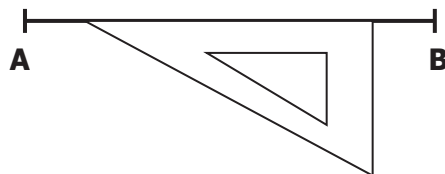

(b) Place the ruler firmly along the set square as shown below.

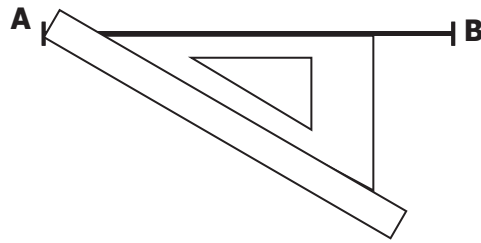

(c) Slide the set square downwards and draw the line on top of the set square as shown below.

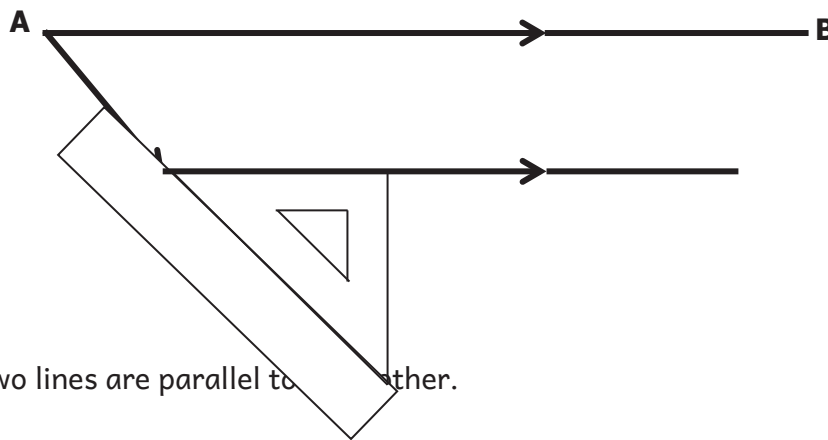

(d) The two lines are parallel to each other.

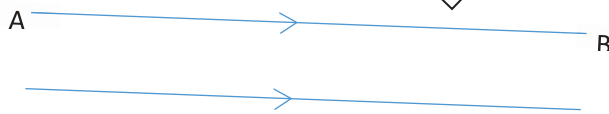

**Exercise**

1. Write true or false

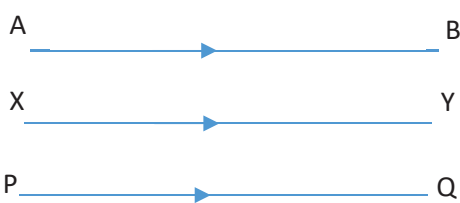

- a) Line AB is parallel to line XY
- b) Line XY is parallel to line PQ
- c) Line AB is parallel to line PQ

2. Name the parallel lines in the diagram below

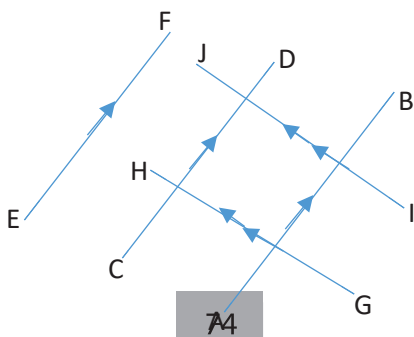



3. Draw a line parallel to line segment XY using a ruler, a set square and a pencil in the space provided.

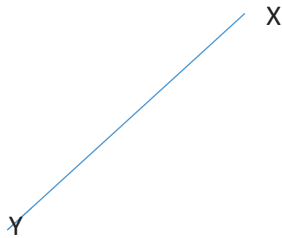

## Lesson 2: Identifying perpendicular lines

**In this lesson you will:**

1. Draw perpendicular lines.
2. Identify perpendicular lines.

**You will need:** a pencil, a pen, a book, a piece of paper, a ruler.

### Introduction.

In the previous lesson, we looked at parallel lines as lines which do not meet. In this lesson, we are going to look at lines that cross each other and meet to form a square corner. These lines are called perpendicular lines. A square corner is basically  $90^\circ$ .

Look at the diagram below for better understanding of perpendicular lines.

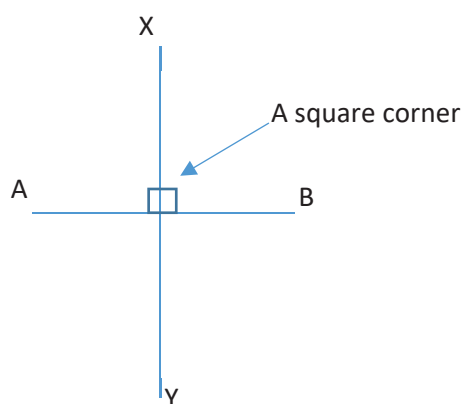

In the diagram above line AB is perpendicular to line XY. Perpendicular lines help builders to make building drawings.

**Step 1**

Get a sheet of paper. Fold the paper in half and in half again to make straight edges, and then unfold. What do you notice after unfolding?

Well, you will see something like this below. These lines are called perpendicular lines.

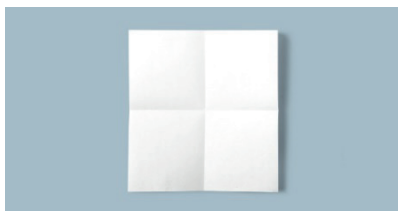

**Step 2.**

Identify objects at home with perpendicular lines.

Well, you may have thought of objects like the ones below:

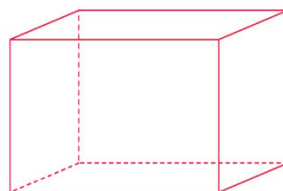

**Step 3**

Look at the following examples

1. Name the perpendicular lines in the diagram below

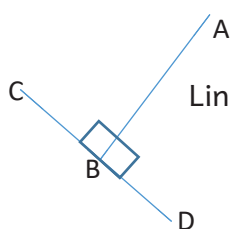

Line AB is perpendicular to line CD because they meet at  $90^\circ$ .

**Exercise**

1. Which angle is formed by perpendicular lines?
2. Use the figure below to identify the pairs of perpendicular lines on the figure



### 3. Identify objects at home with perpendicular lines

#### Lesson 3: Drawing angles using a protractor

In this lesson, you will:

1. Draw angles using a protractor.
2. Name angles.

**You will need:** a sharp pencil, a protractor, a ruler, a pen

#### Introduction

In the previous lesson, we looked at perpendicular lines which meet at  $90^\circ$ . Where they meet is an angle of  $90^\circ$ . An angle is the gap between two meeting lines measured in degrees. In this, lesson we are going to learn the sizes of different angles. The point where two or more lines meet is a vertex.

Look at the diagram below.

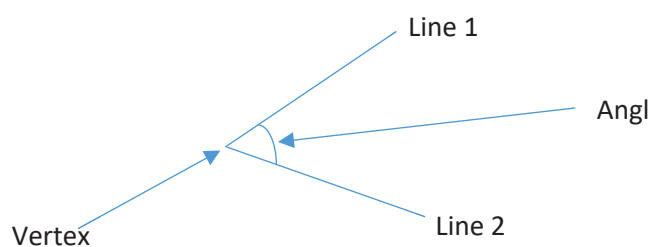

Learning about angles will help you to make accurate construction plans of buildings when you grow up. In this lesson you will need to use a protractor. A protractor is an instrument like this found in your geometry set.

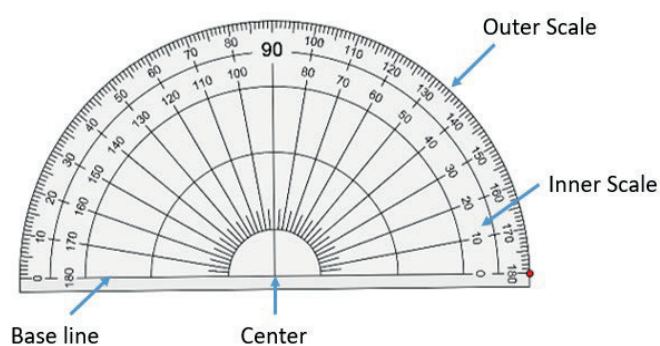

**Step 1: Activity**

Get 2 sticks of equal length and a string. Tie the sticks with the string to make an angle like the one shown below. Trace the angle on the paper. Measure the angle you have traced using a protractor

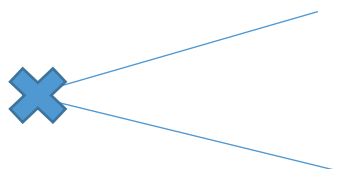

**Step 2: Using a protractor to draw angles**

Look at the following example

- Using a ruler, a protractor and a pencil, only draw an angle of  $60^\circ$  in the space below

Step 1

- Draw a straight line and mark a point to be used as the vertex



Step 2.

- Place the protractor on the line such that its Centre exactly covers point P. The protractor has the inner scale and the outer scale, decide on the one to use. For this example we are Going to use the inner scale.

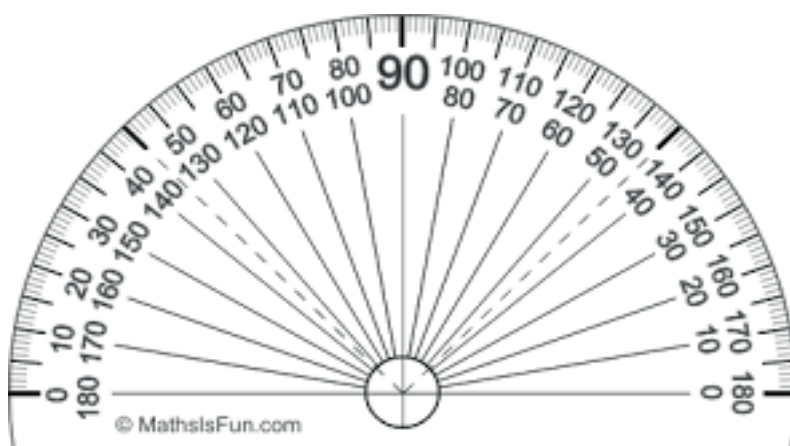

**Step 3**

1. Starting from zero, on the side you want your angle to be, read up to the line where your angle passes and mark it point N. (For this example we are using the inner scale)

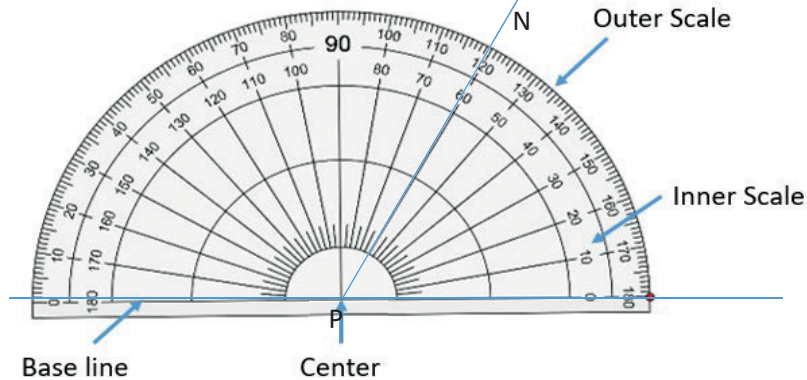
**Step 4**

- 4 Remove the protractor and join the marked point N to the vertex P and label the angle

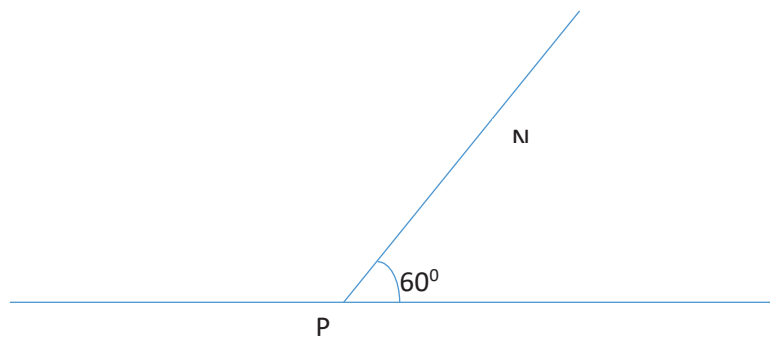
**Exercise**

Using a protractor, a ruler and a pencil only draw, the following angles:

1.  $40^\circ$
2.  $50^\circ$
3.  $80^\circ$
4.  $100^\circ$
5.  $110^\circ$
6.  $125^\circ$

**Lesson 4: Measuring angles using a protractor**

In this lesson, you will:

1. Measure angles using a protractor.
2. Name angles.

**You will need:** a protractor, a ruler, a pencil, a pen, a book

## Introduction

You have already learnt how to draw angles using a protractor. In this lesson you will measure different angles using the protractor. The knowledge used when drawing angles using the protractor will be useful in this lesson. This topic will enable you to gain creative thinking skills which will help you to make accurate construction plans for buildings.

## Step 1

Look at the following examples

- Using a protractor, measure the size of the angle below.

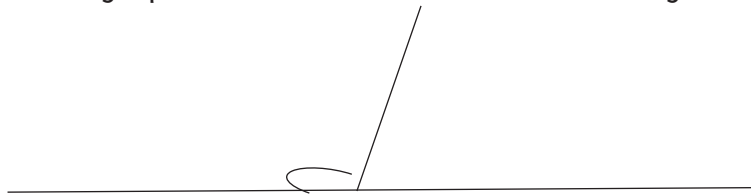

You measure an angle using a protractor. You place the protractor's Centre on the vertex of the angle and the zero mark along one line. Then you can measure the number of degrees in the angle where the second line crosses the protractor. For this example we are going to use the outer scale.

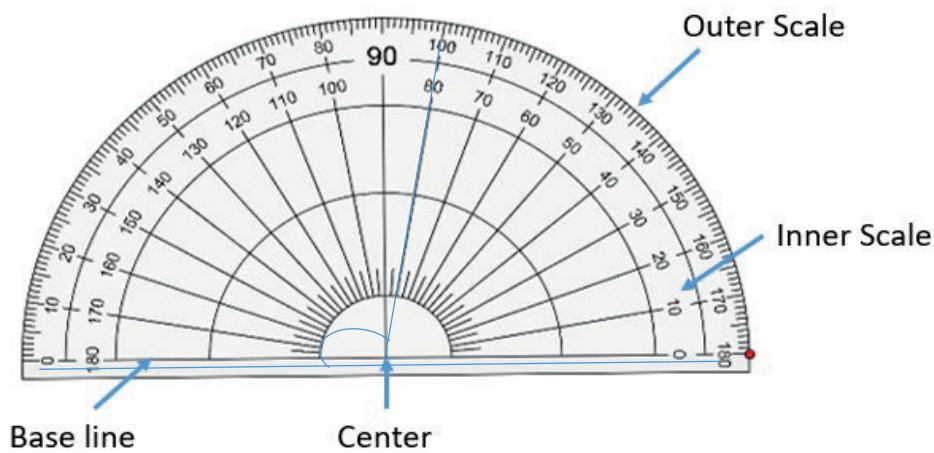

Well, the size of the angle is  $100^\circ$

- Using a protractor, measure the value of the angle shown below

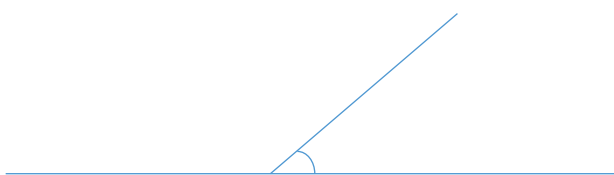

To measure the angle, place the protractor on the line such that its Centre exactly covers the vertex of the angle and measure the angle using the scale of your choice as shown below. For this case use the inner scale.

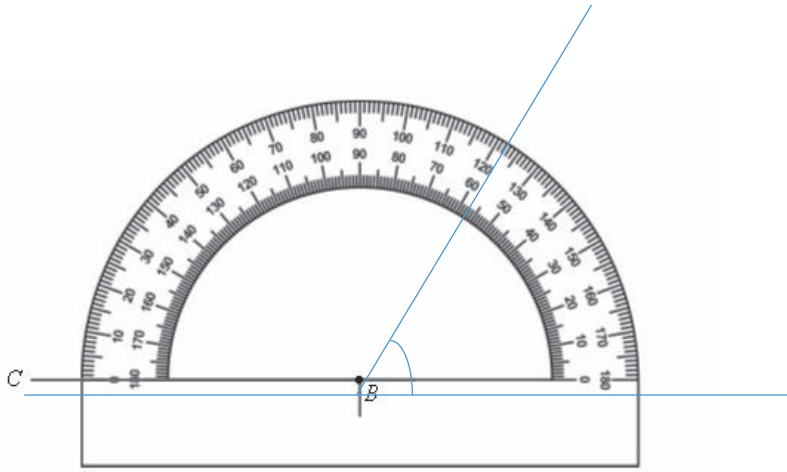

The angle is  $60^{\circ}$

### Exercise

Measure the angles shown below using a protractor

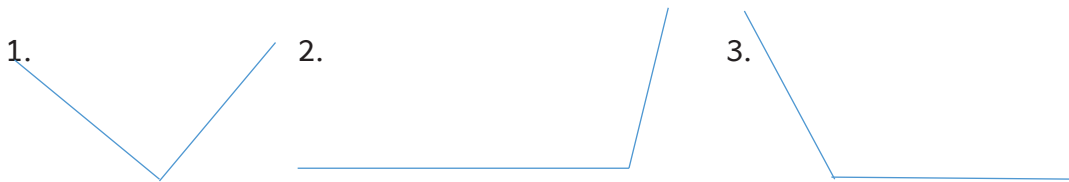

### Lesson 5: Construction of circles

**In this lesson, you will:**

1. Name parts of a circle.
2. Construct circles.

**You will need:** a sharp pencil, a pair of compasses, a ruler, a book, a pen.

### Introduction

In primary four you learnt how to draw a circle, in this lesson, you are going to learn about how to construct a circle and name the different parts of a circle. The knowledge of circles helps us to construct houses with a circular base and also to make circular designs.

**Step 1: Activity.**

You are going to construct a circle of radius 2cm.

Place the pointed tip on the zero line of your ruler. Carefully widen the angle between the arms. Move the pencil tip until it is exactly at 2cm.

Make sure that the pointed tip is still on zero. Be careful not to change the gap once it is set to 2cm.

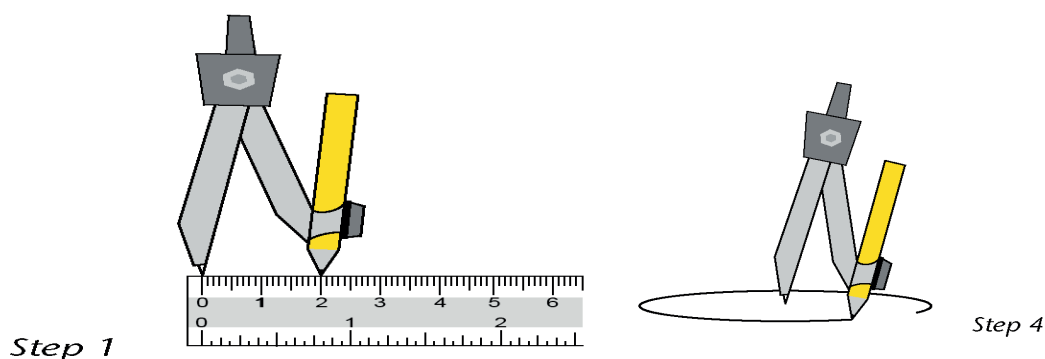

Gently push the pointed tip into point P. let the pencil tip drag over the paper. Push down lightly on the pointed arm as you draw. The pencil tip must move smoothly and lightly.

Step3: Twist the handle between your thumb and the forefinger. Let the pencil tip drag over the paper. Push down lightly on the pointed arm as you draw. The pencil tip must move smoothly and easily.

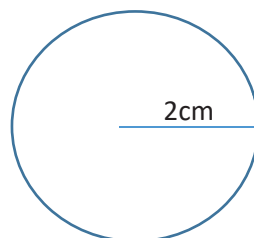

Now this is a complete circle.

**Step 2: Activity**

Using a ruler, a pair of compasses and a pencil only, construct a circle whose radius is 5cm.

Place the pointed tip on the zero line of your ruler. Carefully widen the angle between the arms. Move the pencil tip until it is exactly at 5cm. Make sure that the pointed tip is still on zero. Be careful not to change the gap once it is set to 5cm.



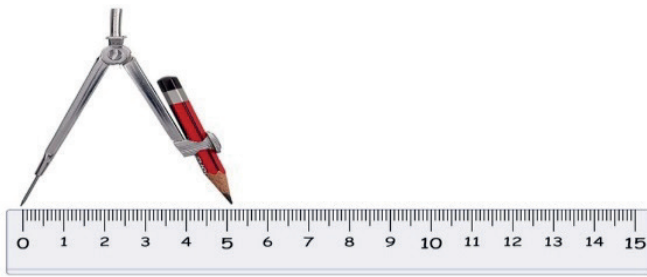

Gently push the pointed tip into point P. Let the pencil tip drag over the paper. Push down lightly on the pointed arm as you draw. The pencil tip must move smoothly and lightly.

Twist the handle between your thumb and the forefinger. Let the pencil tip drag over the paper. Push down lightly on the pointed arm as you draw. The pencil tip must move smoothly and easily.

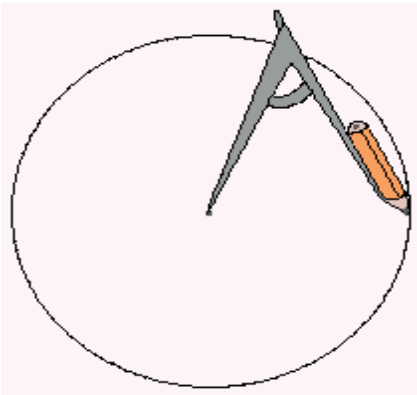

This is a complete circle.

**Example 3.** Draw and name the parts of a circle

Well, the diagram below shows the expected answers

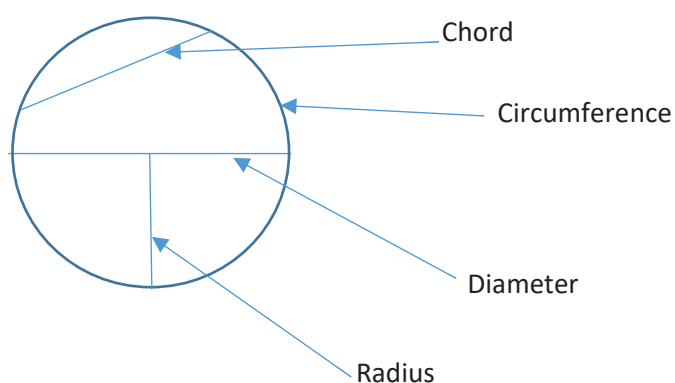

Circumference is the distance round a circle

- A radius is any line segment from the Centre to the circumference

- A chord is a line segment from any point to another point on the circumference of the circle
- A diameter is a line segment from the circumference passing through the Centre of the circle to the next circumference.

**Note**

- The plural of the word radius is radii
- The diameter of a circle has two radii

**Example 1** The diameter of a circle is 14cm. Find its radius

$$\text{Radius} = \text{Diameter} \div 2$$

$$\text{Radius} = 14\text{cm} \div 2$$

$$\text{Radius} = 7\text{cm}$$

**Example 2** Find the diameter of a circle whose radius is 5cm

$$\text{Diameter} = 2 \times \text{radius}$$

$$\text{Diameter} = 2 \times 5\text{cm}$$

$$\text{Diameter} = 10\text{cm}$$

Or

$$\text{Diameter} = r + r$$

$$\text{Diameter} = 5\text{cm} + 5\text{cm}$$

$$\text{Diameter} = 10\text{cm}$$

**Exercise**

- Using a ruler, a pair of compasses and a pencil only construct a circle whose radius is:
  - 4cm
  - 3cm
  - 5cm
- Using a ruler, a pair of compasses and a pencil only construct a circle whose diameter is :
  - 10cm
  - 12cm
  - 8cm

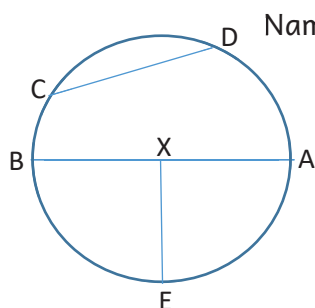

Name the following parts:

- XE
- AB
- CD
- ADCBEA

## Lesson 6: Describing lines of folding symmetry

In this lesson, you will:

1. Describe lines of symmetry.
2. Identify lines of symmetry.

**You will need:** a pencil, a ruler, a pen, a book, a square paper

### Introduction

A line of symmetry is that line that divides a plane figure into two equal parts. Humans, animals and insects have one line of symmetry. An easy way to check whether the figure has a line of symmetry is to fold it half. If the two halves match exactly, the figure is symmetric about the fold. Symmetry is very important because it allows you to understand the things you see every day in different context. This topic will help you to recognize symmetry in nature, in art and in common objects and symbols.

### Step 1

- Get a square paper.
- Fold it such that the two halves cover each other without overlapping.



How many folds can allow the halves of a square to cover each other?

Great! The answer is right here:

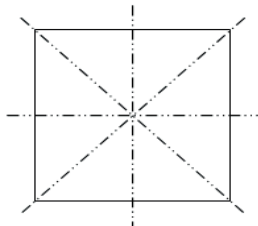

4 folds only.

### Step 2: Look at the following examples

1. Count the lines of symmetry in the following figures:

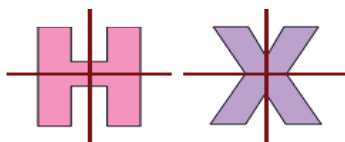

Letter H has 2 lines of **folding** symmetry.

Letter X has 2 lines of **folding** symmetry.

Can you think of other letters which have **folding** lines of symmetry?

b)

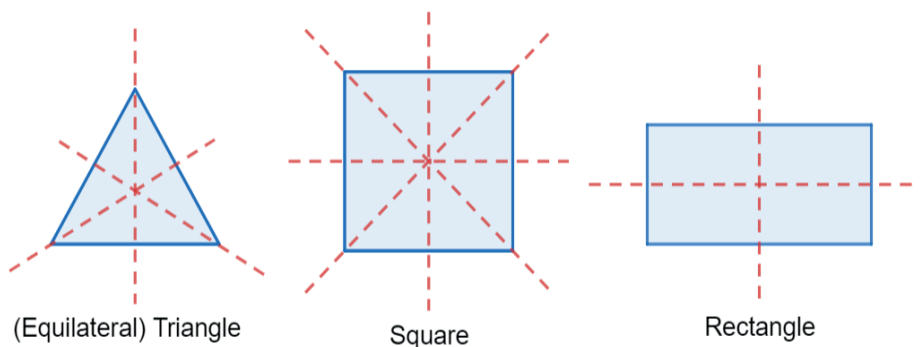

1. An equilateral triangle has 3 **folding** lines of symmetry.
2. A square has 4 **folding** lines of symmetry.
3. A rectangle has 2 **folding** lines of symmetry.

**Exercise**

1. Draw a line of symmetry in each of the diagrams below.



2. Find the number of lines of folding symmetry in the figures shown below:

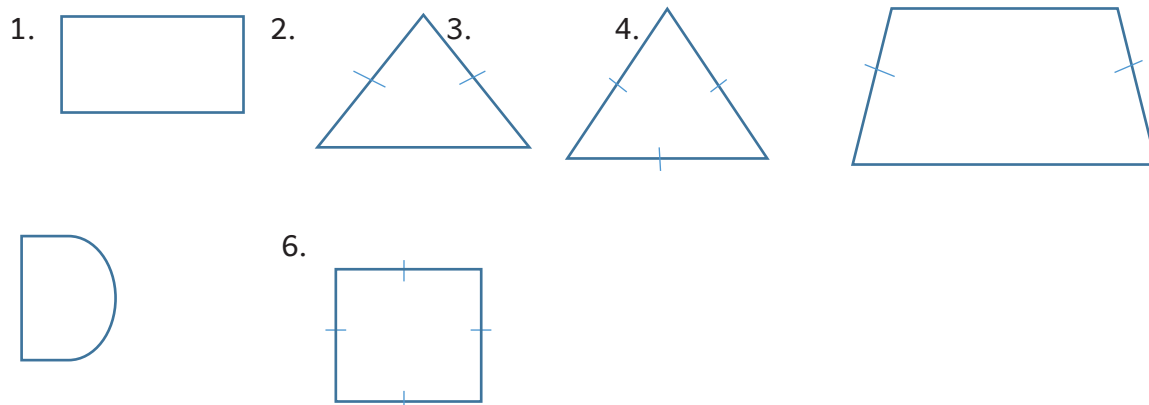

**Lesson 7: Rotation and revolution**

**In this lesson, you will:**

1. Find rotations and revolutions
2. Follow instructions to draw rotations and revolutions.

**You will need:** a pencil, a pen, a book, a pen

**Introduction.**

Rotations make things turn in a cycle around a definite Centre point. A rotation is a turn from a fixed point. The amount of rotation is described in terms of degrees. In rotation, the figure will not change size, or shape but will change direction. Therefore in today's lesson, we are going to learn about revolution or rotation. That is understanding the angles you make in the different turns.

**Step 1: Activity**

Let us look at an example.

Fix your heel at one point. Use your first toe to mark another point. Move your foot with the first toe until you come back to the original point. The complete turn you have made is called a revolution or rotation or turn.

You will notice that the move you make looks like below:

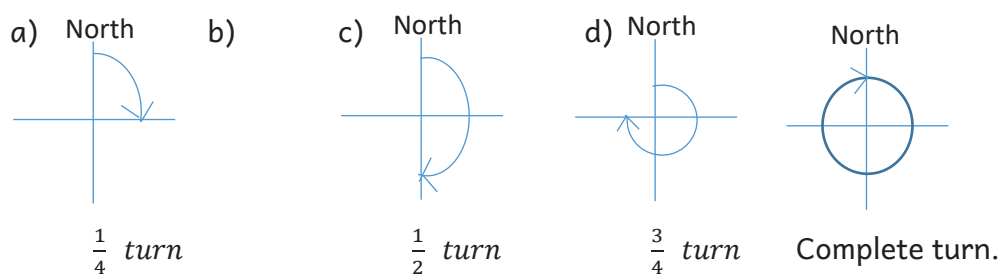

This topic trains you to get ready for a match pass. That is understanding the angles you make in the different turns.

The following activity will help you to understand this topic very well

**Step 2**

Move or turn round once at a central fixed point. The turning you make is called a rotation or revolution

**Step 3**

Look at the following examples

Take note of the following:

- One complete turn or revolution is equal to  $360^{\circ}$ . This is the same angle made by a minute hand of a clock to make 60 minutes or one complete turn.
- A half turn or a straight angle is equal to  $180^{\circ}$
- Three quarter turn is equal to  $270^{\circ}$

- A quarter turn is equal to  $90^\circ$
1. How many degrees are there in a quarter turn?

$$\begin{aligned}
 1 \text{ complete turn} &= 360^\circ \\
 \frac{1}{4} \text{ Of a turn} &= \frac{1}{4} \times 360^\circ \\
 &= 90^\circ
 \end{aligned}$$

1. Find the number of degrees in  $\frac{1}{2}$  of a turn

$$\begin{aligned}
 1 \text{ complete turn} &= 360^\circ \\
 \frac{1}{2} \text{ Of a turn} &= \frac{1}{2} \times 360^\circ \\
 &= 180^\circ
 \end{aligned}$$

2. Find the number of degrees in  $\frac{2}{3}$  of a revolution

$$\begin{aligned}
 1 \text{ complete revolution} &= 360^\circ \\
 \frac{2}{3} \text{ Of a revolution} &= \frac{2}{3} \times 360^\circ \\
 &= 240^\circ
 \end{aligned}$$

3. What turn is made in an angle of  $120^\circ$ ?

$$\begin{aligned}
 360^\circ &= 1 \text{ complete revolution} \\
 120^\circ &= \frac{120}{360} \times 1 \text{ complete revolution} \\
 &= \frac{1}{3}
 \end{aligned}$$

### Step 3

#### Exercise

1. How many degrees are there in :  
 a)  $\frac{1}{4}$  turn (b)  $\frac{3}{4}$  turn (c)  $\frac{2}{3}$  turn (d)  $\frac{1}{6}$  turn
2. Find the fraction of a revolution representing these degrees  
 a)  $180^\circ$  (b)  $90^\circ$  (c)  $270^\circ$  (d)  $360^\circ$
3. Write the fraction and degrees shown on the diagrams below

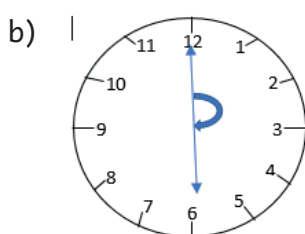
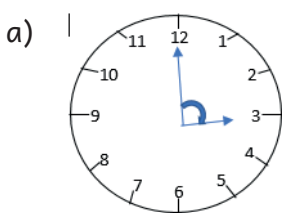

### Lesson 8 : Drawing diagrams to show rotations and revolutions

#### In this lesson, you will:

1. Follow instructions to draw rotations and revolutions.
2. Find angles on a compass.
3. Make clockwise and anti-clockwise turns.

**You will need:** a pencil, a pen, a book.

### Introduction

An instrument used to show direction is called a magnetic compass. A magnetic compass has 8 main directions namely: North (N), North East (NE), East (E), South East (SE), South (S), South West (SW), West (W), North West (NW). This topic prepares you to develop creative thinking skills which will enable you to locate the direction of one place from another.

To understand this better look at the diagram below;

### Step 1

Study the angles between the compass direction. The small angle between North and East is  $90^\circ$ .  $90^\circ$  divided by 2 equals to  $45^\circ$ . Then what is the small angle between North and North East?

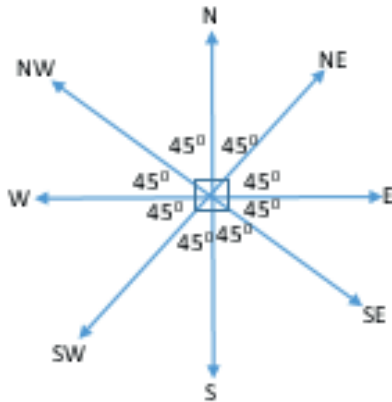

Well,  $45^\circ$  is the small angle between North and North East.

**Step 2:** Look at the following examples

**Example 1.** What is the smaller angle between North and East?

Draw a 4 point compass like the one shown below. The smaller angle is represented by the shortest curve between North and East.

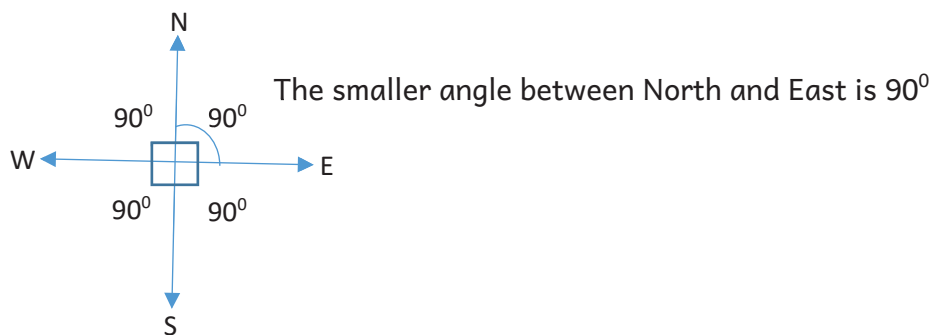

**Example 2.** What is the smaller angle between East and South west?

Draw an 8 point compass like the one shown below. The smaller angle is represented by the shortest curve between East and South West

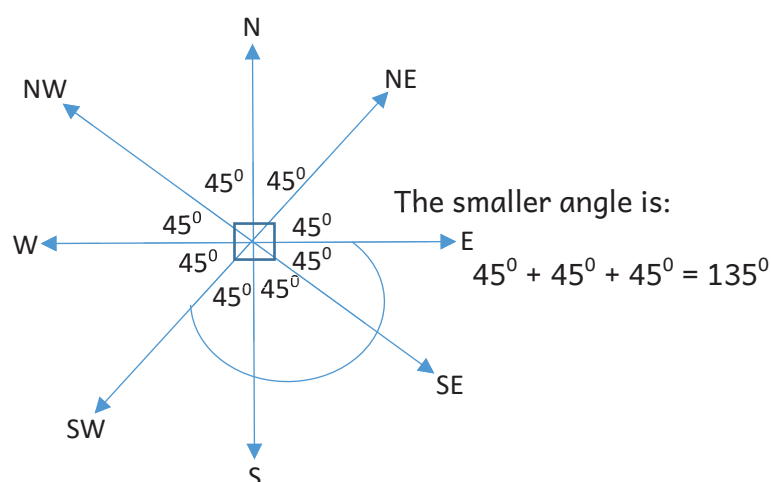

**Example 3.** What is the larger angle between North and West?

Draw a 4 point compass like the one shown below. The larger angle is represented by the longest curve between North and West

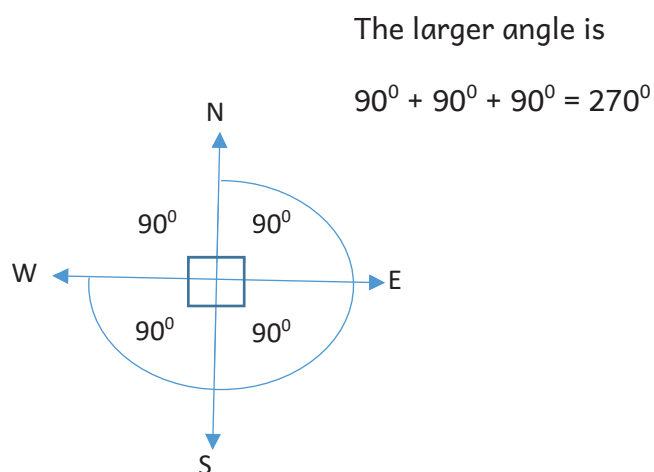

**Example 4.** Bangi was facing North. She turned clockwise to face south east. What angle did she make?



**Note:**

The direction to which clock hands move is called clockwise. The opposite direction to which the clock hands move is called anti-clockwise. Look at these diagrams to make you understand it better.

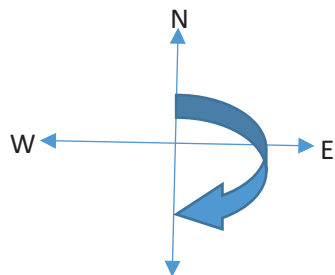

Right hand turn (clockwise)

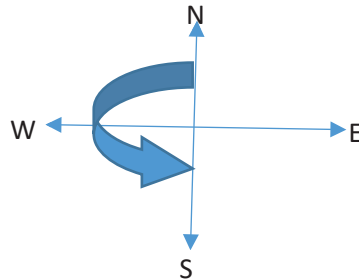

Left hand turn (anti-clockwise)

You have to draw an 8 point compass as indicated below.

First locate North on the compass, then move in clockwise direction until you reach South East direction. Finally add all the angles within the range.

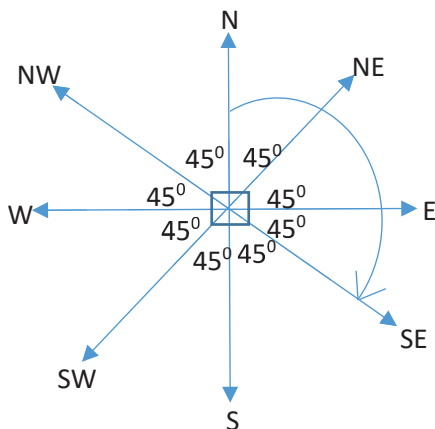

The angle is;  
 $45^{\circ} + 45^{\circ} + 45^{\circ} = 135^{\circ}$

**Example 4.** Mutesi was facing west. She turned anti-clockwise through an angle of  $135^{\circ}$ . In which direction did she face?

You have to draw an 8 point compass as shown below.

First locate West on the compass, then add the groups of  $45^{\circ}$  in anti-clockwise direction until you make  $135^{\circ}$ .

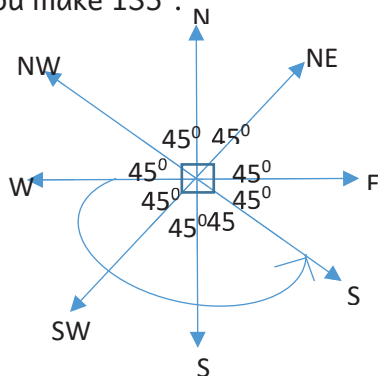

The new direction is South East.

### Exercise

1. What is the smaller angle between:
  - a) North and West?
  - c) North west and South East?
2. What is the larger angle between :
  - a) East and North?
  - c) East and North east?
3. Mary is facing North. What angle will she make if she turns clockwise to face South?
4. Amina was facing East. She turned clockwise through an angle of  $180^\circ$ . In which direction did she face?
5. Peter is facing South. What angle will he make if he turns anti-clockwise to face East?
6. Salim was facing West. He turned anti-clockwise through an angle of  $90^\circ$ . In which direction did he face?

## TOPIC: DATA HANDLING

### Lesson 1: Scales on the horizontal and vertical axis

**In this lesson, you will:**

1. Draw and recognize scales on the horizontal and vertical axes.
2. Read scales on the horizontal and vertical axis.

**You will need:** a pencil, a pen, a book, a ruler

#### Introduction.

You have been already introduced to handling data using pictographs where the horizontal and vertical axes were not used. In P.5 you are going to look at

graphs that will require you to have the knowledge of horizontal and vertical axes. The axes are the horizontal and vertical lines used to frame a graph or chart. The horizontal axis is the line running from left to right (think of the lines on your writing paper). The vertical axis is the upright line (think of your writing paper turned sideways). This will help you when handling large data of different categories.

**Look at this graph below**

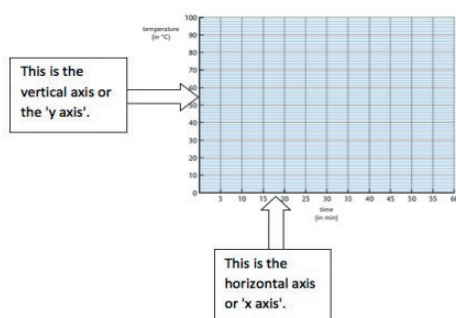

- The horizontal axis shows what one small square on the horizontal axis stands for.
- The vertical scale shows what one small square on the vertical axis stands for.
- The plural of axis is axes.

This topic will enable you to develop critical thinking skills which will help you to read and interpret graphs in magazines and News- papers.

### Step 1: Activity

- Draw a left – to – right straight line
- Mark and write numbers 0 to 5 at equal distances
- Draw an upright line to the left of the line you drew at first
- Mark and write numbers 0 to 10 at equal distances with 1 small division equal to 2.
- Name the left to right straight line you have drawn
- Name the upright line you have drawn

Well, you may have drawn a graph like this one b

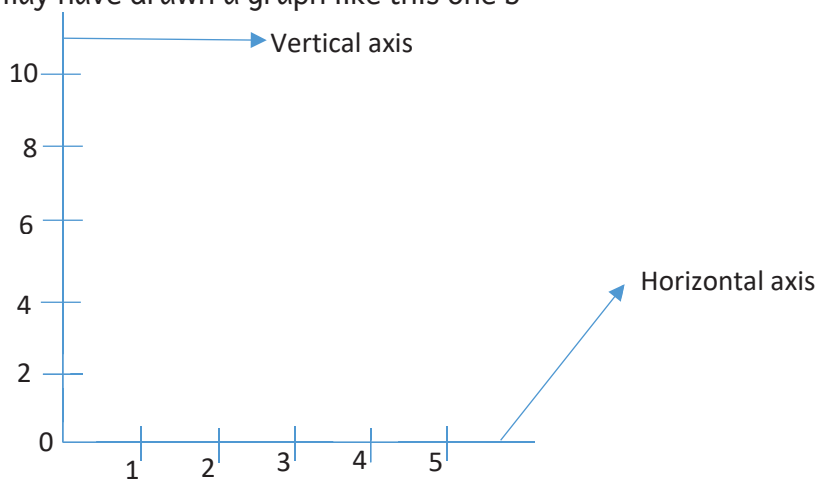

Step 2.

Look at the following example.

1. Draw horizontal and vertical axes. On the vertical axis show **the** number of pupils with 1 square representing 10 pupils. On the horizontal axis show **the** days of the week with 1 square representing 1 day.

#### Vertical scale.

1 square represents 10 pupils. This means that we are going to count in tens from 0 so as to complete the vertical axis that is: 0, 10, 20, 30, 40, 50 ...

**Horizontal scale.**

1 square represents 1 day. This means that in every square there will be only 1 day.

Note that 0 lies on both axes.

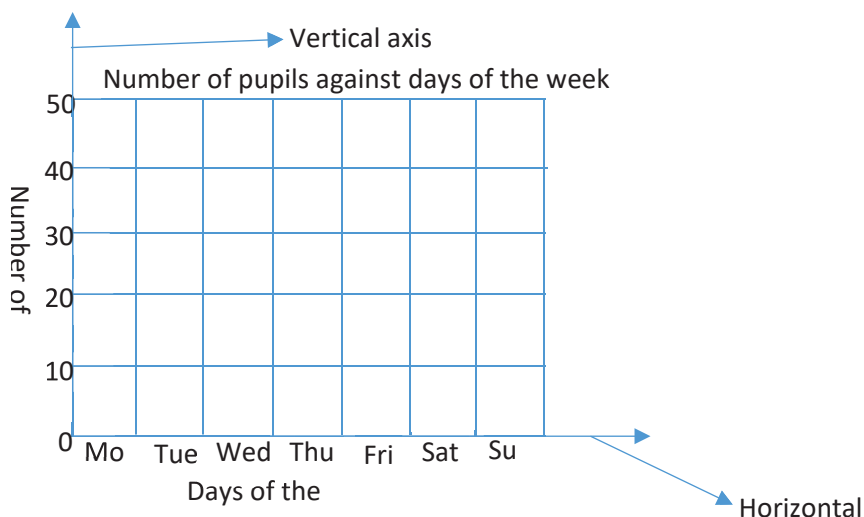

**Exercise**

1. Draw the vertical and horizontal axes
  - a) On the vertical axis show number of pupils with one small square representing 5 pupils
  - b) On the horizontal axis show days of the week with 1 small square representing 1 day
2. Draw the vertical and horizontal axes
  - a) On the vertical scale show rain in millimetres, with one small division representing 20 millimetres.
  - b) On the horizontal axis show the first six months of the year with one small division representing 1 month.

**Lesson 2: Bar graphs**

**In this lesson, you will:**

1. Draw bar graphs.
2. Read and interpret information on bar graphs.

**You will need:** a pen, a pencil, a book

**Introduction:** A bar graph makes it easy to compare sets of data between different groups. It looks like a bar of soap. Look at this graph.

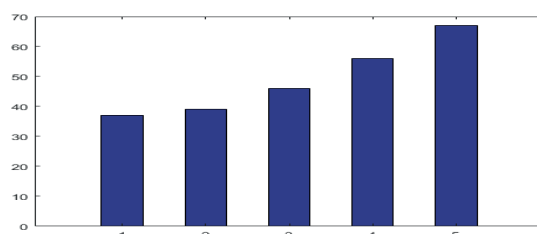

Bar graphs or bar diagrams are helpful in representing the data visually. The length of each bar represents the required information. Choosing a right scale for a bar is important. Scale means the number used to represent one unit length of a bar. For example 1 unit length represents 100 children. Like any other graph a bar graph should have:

- A title to explain what the graph is about.
- The scale to show the units used on the bar graph.
- Labels to tell what kind of data is shown on both axes.

The height of each bar represents a number.

This topic will help you to interpret bar graphs in News-papers and magazines.

### Step 1: Example.

Look at the following example.

1. The table below shows the sacks of maize which were produced in a week by a milling company. Use it to answer the following question.

Days of the week	Mon	Tue	Wed	Thur	Fri
Number of sacks	20	25	30	15	10

Draw a bar graph to show the above information.

### The vertical scale

1 small square represents 5 sacks

Horizontal scale

1 small square represents 1 day

A bar graph showing the sacks of maize produced by a milling company in a week

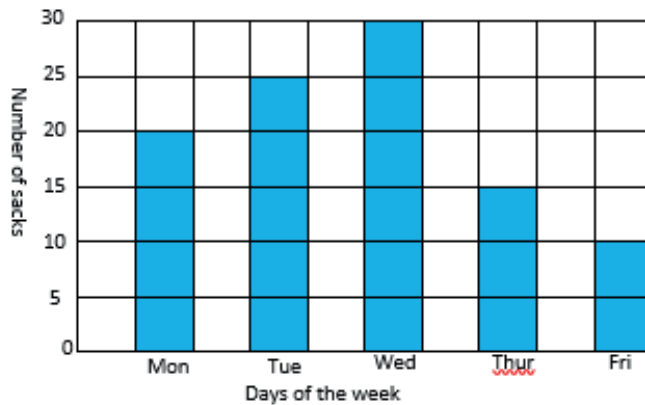

### Exercise

- The table below shows the ages of pupils in a school. Use it to answer the following questions

Age in years	12	10	8	6	4
Name of pupils	Angel	Ali	Dorcus	Mary	Amina

Draw a bar graph to represent the above information.

2. The table below shows the number of pupils who visited Entebbe airport in a week. Use it to answer the following questions:

Days of the week	Mon	Tue	Wed	Thur	Fri
Number of pupils	300	350	200	150	400

Draw a bar graph in the graph provided to show the above information

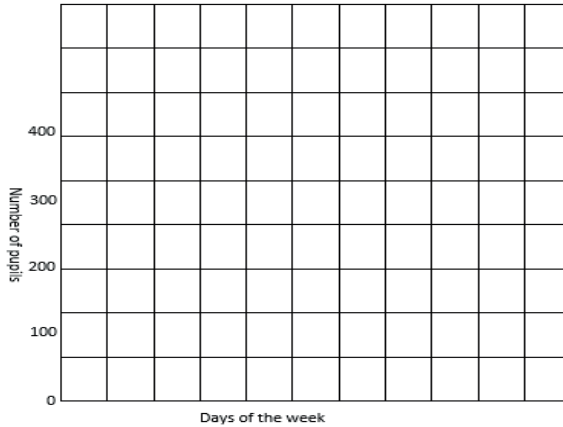

### Lesson 3: Bar graphs

In this lesson, you will:

1. Interpret information on bar graphs.
2. Read information on bar graphs.

**You will need:** a pencil, a pen, a ruler, a book

#### Introduction

In the previous lesson we learnt how to draw bar graphs, in today’s lesson, we are going to learn how to read and interpret information on a bar graph. This topic will help you to interpret bar graphs that you see in magazines and News-papers.

#### Step 1: Example.

Look at the example below.

1. The bar graph below shows the number of pupils who attended school in a week. Use it to answer the following questions

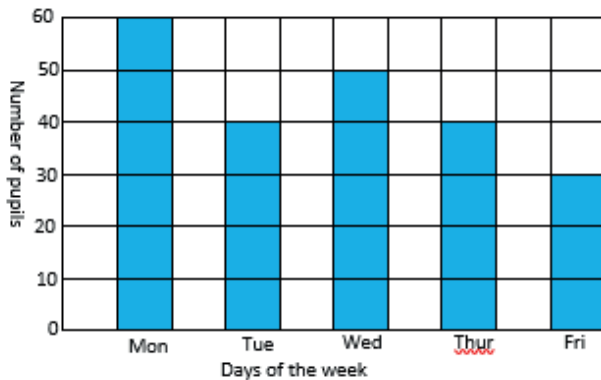

What does the vertical axis show?

The vertical axis shows the number of pupils.

a) What does the horizontal axis show?

The horizontal axis shows the days of the week.

b) Find the number of pupils who attended on Monday

Find Monday on the horizontal axis. Follow up the bar up to the end. Where it ends, read the figure which corresponds to it on the vertical axis, in this case 60 is our target number.

60 pupils attended on Monday.

c) Which day had the highest attendance?

Monday had the highest attendance

d) What is the vertical scale?

From 0 the next number is 10. This implies that the range (highest – lowest) is 10.

Therefore 1 small square represents 10 pupils.

1 small square represents 10 pupils

### Exercise

1. The bar graph below shows the number of pupils who attended school in a week. Use it to answer the following questions

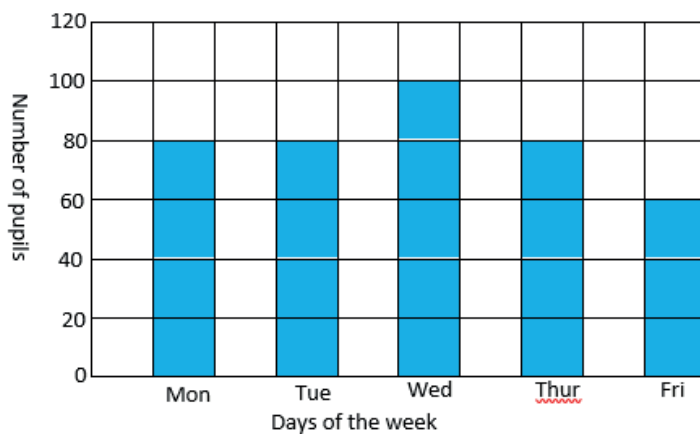

(a) What does the horizontal axis show?

(b) How many pupils attended on Wednesday?

(c) Which day had the lowest attendance?

(d) What is the vertical scale

2. The graph below shows the number of eggs which were sold in a week. Use it to answer the following questions.

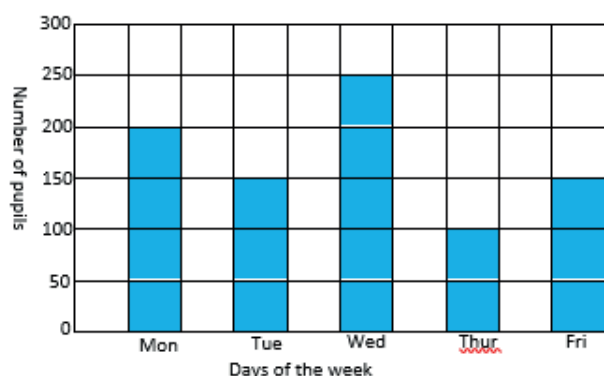

- Which day had the highest number of eggs sold?
- On which days were the same number of eggs sold?
- How many eggs were sold on Monday?
- What is the vertical scale?

### Lesson 4: Line graphs

In this lesson, you will:

- Draw line graphs.
- Read information on line graphs
- Read scales on the horizontal and vertical axis

You will need: a pencil, a pen, a book

### Introduction

Line graphs are often called broken line graphs. Line segments connect the points on the graph. The segments joined end- to – end look like a broken line.

Look at the graph below.

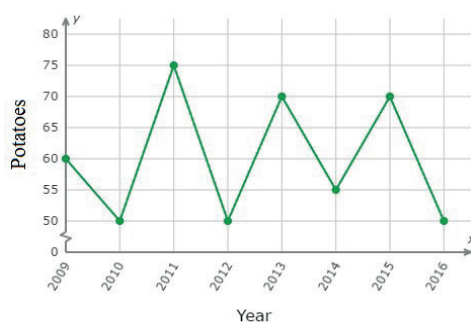

Like any other graph a line graph should have:

- A title to explain what the graph is about.



- b) The scale to show the units used on the graph  
 c) Labels to tell what kind of data is shown on the axes.

The knowledge of line graphs helps a Doctor to draw immunization health charts for children who are taken for immunization.

### Step 1

The following table shows the number of pupils who attended class in a week

Days of the week	Mon	Tue	Wed	Thur	Fri
Number of pupils	50	50	50	40	50

Now, instead of drawing bars, mark with stars where the number of pupils corresponds with the day of the week.

Well, compare what you have drawn with this one below;

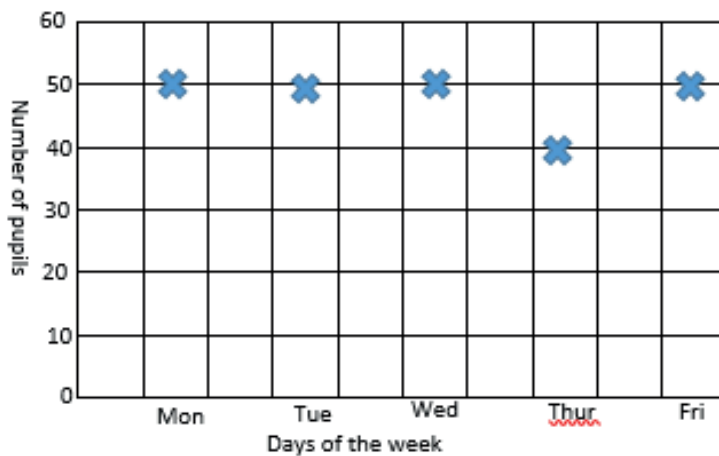

### Step 2: Look at the following example

Example 1. The table below shows the goals which were scored by netball team during the league. Study and answer the following question.

Rounds	1 <sup>st</sup>	2 <sup>nd</sup>	3 <sup>rd</sup>	4 <sup>th</sup>
Number of goals	18	12	24	15

Draw a line graph to represent the above information

**Vertical scale:**

**Horizontal scale**

2 squares represent 6 goals.

2 squares represent 1 round.

1 square represents  $\frac{6}{2}$  goals

1 square represents 3 goals

A line graph showing the goals scored by a netball team in a league

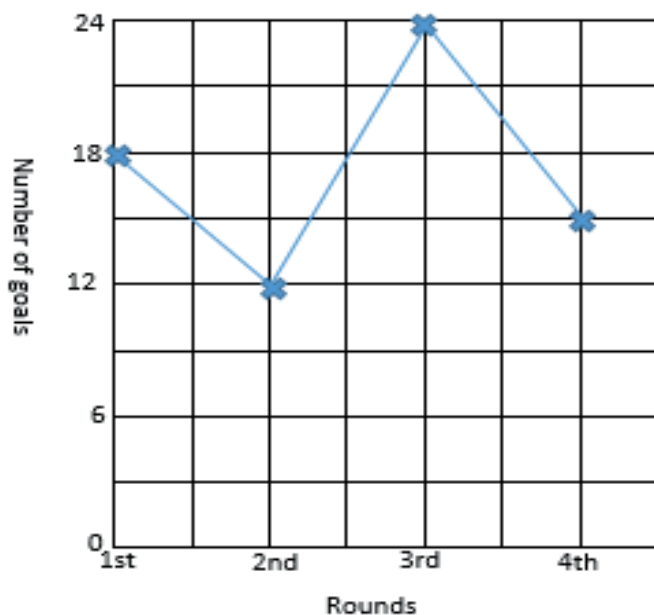

**Exercise**

- The table below shows the marks scored by a P.5 pupil in a test. Use it to answer the following question

Name of subject	Maths	Scie	Eng	Sst
Marks scored	100	90	70	80

Draw a line graph in the graph below to represent the above information

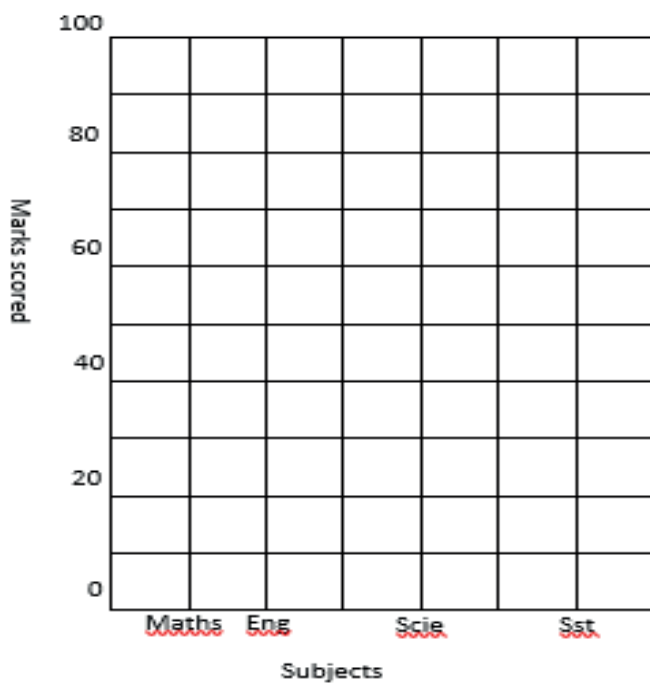

2. The table below shows the temperature of a place recorded in a week. Use it to draw a line graph for the information.

Day of the week	Mon	Tue	Wed	Thur	Fri
Temperature ( $^{\circ}\text{C}$ )	21	24	18	21	18

## Lesson 5: Line graphs

**In this lesson, you will:**

1. Read and interpret information on line graphs.
2. Read scales on the vertical and horizontal axis.

**You will need:** a pencil, a pen, a book.

### Introduction.

In the previous lesson, we learnt how to draw line graphs. In today's lesson we are going to learn how to read and interpret information on line graphs. Line graphs show how something has changed over a period of time.

### Step 1

What is the difference between a line graph and a bar graph?

Well, the answer is right here: Line segments connect points on a line graph whereas bars are used to show information on a bar graph.

### Step 2

**Look at the following example:**

1. The graph below shows the sacks of maize flour which were sold in a week by Okello. Use it to answer the following questions.

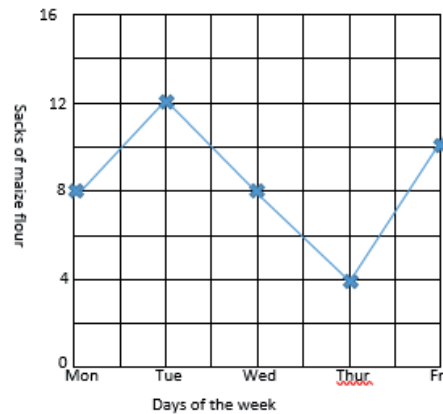

- a) How many sacks were sold on Monday?  
Look at the horizontal axis on Monday. Follow up the line from Monday vertically up to the star. Where the star is, read the number of sacks which corresponds to it on the vertical axis. For this case the wanted number is 8  
8 sacks were sold on Monday
- b) On which day did Okello sell 4 sacks  
Look at 4 on the vertical axis. Move horizontally from 4 until you meet the star which corresponds to 4. From the star, move vertically downwards and read the day which corresponds to it. For our case the wanted day is Thursday.  
4 sacks were sold on Thursday

- c) How many sacks did he sell on Friday?

Look at the horizontal axis on Friday. Follow up the line from Friday vertically up to the star. Where the star is, read the number of sacks which correspond to it on the vertical axis. For this case the wanted number is between 8 and 12 and this must be 10.

10 sacks were sold on Friday

**Exercise**

1. The graph below shows the trays of eggs which were sold by a farmer in a week. Use it to answer the following question:

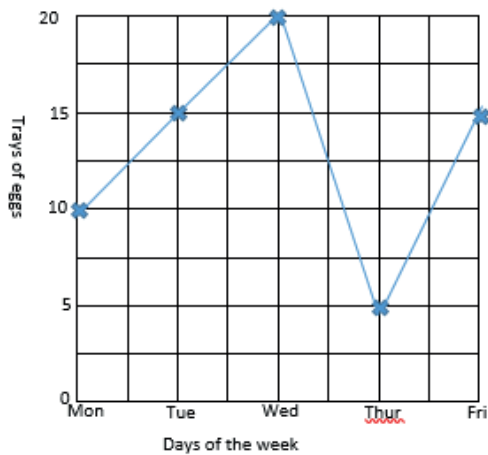

- a) How many trays of eggs were sold on Tuesday?

- b) On what day did the farmer sell 10 trays of eggs?

- c) Which day had the highest sales?

2. The graph below shows the goals scored by different teams in a competition. Use it to answer the following questions

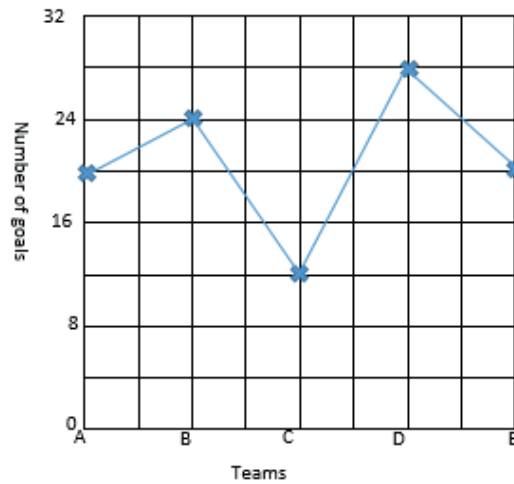

- a) How many goals were scored by team A?  
 b) Which team scored the highest number of goals?  
 c) Which teams scored the same number of goals?  
 d) Which team scored 12 goals?

**Lesson 6: Average**

In this lesson you will:

1. Find average
2. State the uses of average.
3. Find the average on bar graphs.

You will need: a pen, a pencil, a book, counters

**Introduction**

Average is used in everyday life to show a central value of amount for a group of people or things. The average is the value that can replace every existing item, and have the

same result. The average is calculated by adding up all of the numbers in the data given and then dividing by the number of items. Averages are useful because they summarize a large amount of data into a single value. Average is sometimes called mean.

Find **the** mean do the following:

### Step 1

- Get 8 counters
- Arrange the counters one at a time into 4 groups
- Count the counters in each group.



Well, each group has 2 counters.

- The sum of all the counters divided by the number of groups gives you the average or mean

$$\frac{8}{4} \text{ Counters} = 2 \text{ counters}$$

### Step 2

Look at the following examples

**Example 1.** Find the average of 10, 8, 12, and 18.

$$\text{Average} = \frac{\text{Total}}{\text{Number of items}}$$

**Add the numbers:  $10 + 8 + 12 + 18 = 48$**

$$\text{Average} = \frac{10 + 8 + 12 + 18}{4}$$

**Divide the sum by the number of items:  $48 \div 4$**

$$\text{Average} = \frac{48}{4}$$

$$\text{Average} = 12$$

**Example 2.** Daphine scored the following marks in a series of tests: 96, 92, 80, 84, 98.

Find her average score.

$$\text{Average} = \frac{\text{Total}}{\text{Number of items}}$$

**Add the numbers:  $96 + 92 + 80 + 84 + 98 = 450$**

$$\text{Average} = \frac{96 + 92 + 80 + 84 + 98}{5}$$

**Divide the sum by the number of items:  $450 \div 5$**

$$\text{Average} = \frac{450}{5}$$

$$\text{Average} = 90$$

**Example 3.**

1. The graph below shows the number of pupils who attended school in a week. Use it to answer the following questions

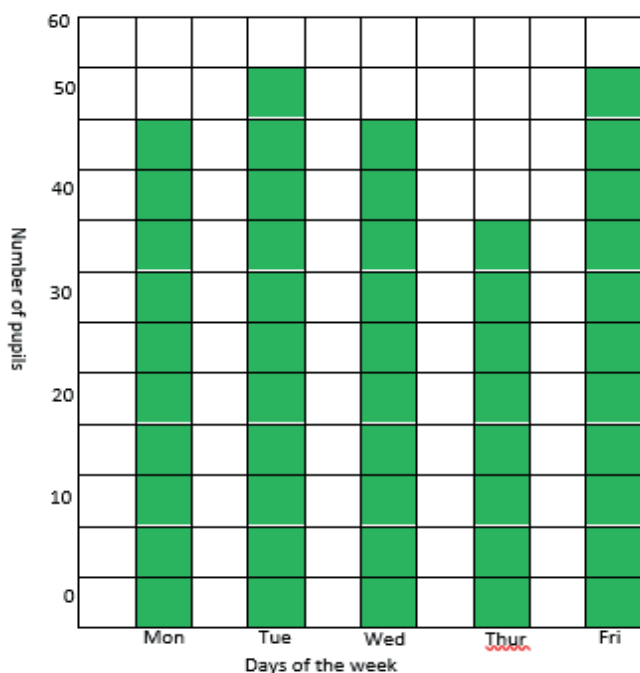

- a) How many pupils attended school on Monday?  
 Look at the horizontal axis on Monday. Follow the bar for Monday up to the end. Where it ends read the number that corresponds to it on the vertical  
 50 pupils attended on Monday.
- b) Which day had the lowest attendance?  
 The lowest bar represents the day and this was on Thursday.

c) Find the average attendance for the week

**Write down the attendance for each day as follows:**

Mon: 50 pupils, Tue: 55 pupils, Wed: 50pupils, Thur: 40 pupils, Fri: 55 pupils.

$$\text{Average} = \frac{\text{Total}}{\text{Number of items}}$$

**Add all the numbers:  $50 + 55 + 50 + 40 + 55 = 250$**

$$\text{Average} = \frac{50 + 55 + 50 + 40 + 55}{5}$$

**Divide the sum by the number of items:  $250 \div 5$**

$$\text{Average} = \frac{250}{5}$$

$$\text{Average} = 50$$

## Exercise

Try the following numbers

- Find the average of the following numbers
  - 4, 6, 2, 8, 5
  - 25, 5, 15, 10, 20
  - 8, 10, 12, 6, 9, 15
- Adek scored the following marks in a test: 98%, 91%, 75%, and 74%. Find her average score.
- Find the average age of 4 pupils whose ages are: 11 years, 13 years, 12 years and 8 years
- Find the average height of 5 pupils whose heights are: 127cm, 135cm, 100cm, 130cm and 128cm.
- The bar graph below shows the number of Christians who went for prayers in a day. Use it to answer the following questions.

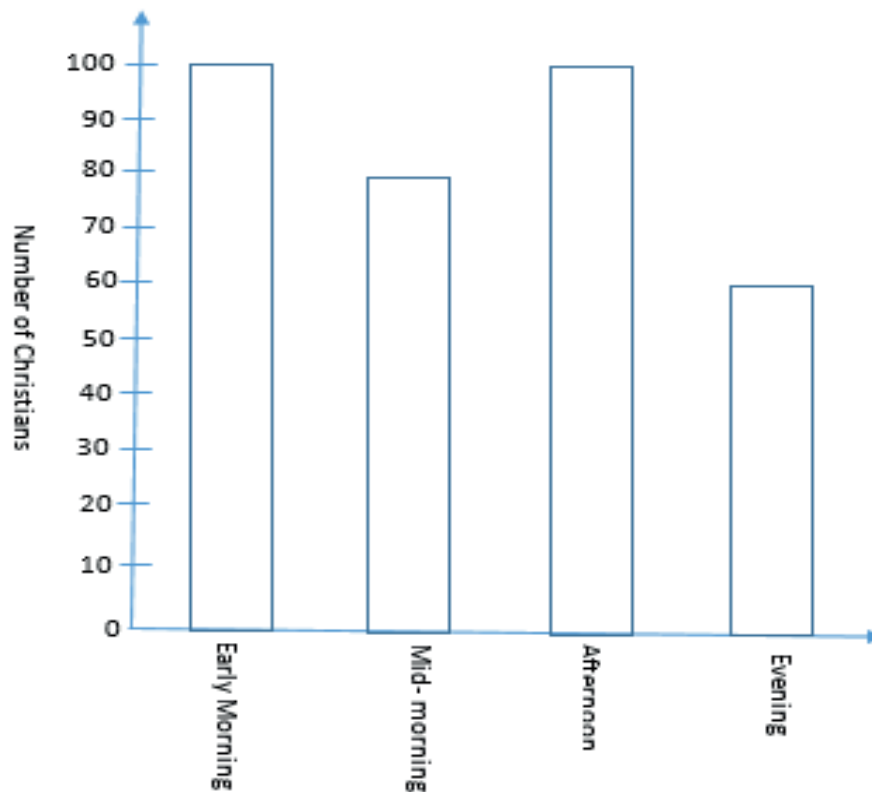

- Find the number of Christians who attended the first service.
- Which service had 80 Christians?
- Which service had the lowest attendance?
- Find the average attendance for the day.

## TOPIC: TIME

### Lesson 1: Time on the 12 hour clock

**In this lesson, you will:**

1. Tell time on the 12 hour clock.
2. Recognize minutes and seconds

You will need: a pencil, a pen, a book, a pair of compasses.

#### Introduction

Knowing how to tell time can help you to determine whether you're running late or whether you have time to spare. For example, you can catch a train, bus or plane on time.

In lower classes you were telling time using natural events. In this class you are going to tell time using a clock or a watch.

A clock face is made up of 3 hands. The hour hand (the shortest) and the minute hand which is usually longer than the hour hand. The **third** hand is the longest and rotates at a high speed.

On a clock face when the minute hand moves from one number to the next, 5

minutes have passed. You can count by fives for each new number on a clock face to find out how many minutes have passed since the hour. The 12 hour clock runs from 1a.m to 12 noon and then from 1p.m to 12midnight.

#### Step 1

Do you remember what a.m. and p.m. mean?

- The a.m. times are the hours from 1a.m after midnight to 11:59a.m before noon. These are morning hours. "a.m." means before noon.
- Time after noon is called p.m. The p.m. hours are from noon to 11:59p.m before midnight. These are a combination of both afternoon and evening hours. "p.m." means after noon.
- So in each day there 12 a.m. hours and 12 p.m. hours. Which make 24 hours in a day.

#### Step 2

Look at the following examples

1. What morning time is shown on the clock face below?



On this clock face the minute hand is on the 12 which means 00 minute past the hour. The hour hand is pointing to 3 which means that it is 3 o'clock.



Therefore the time is 3: 00a.m

2. What afternoon time is shown on the clock face below?



- On this clock the minute hand is on the 10. How many minutes have passed since the hour? Count by fives starting by 1 on the clock (touch each number on the clock face as you count aloud) 5, 10, 15, 20, 25, 30, 35, 40, 45, 50. So when the minute hand is on the 10, 50 minutes have passed since the hour.
- Now look at the hour hand, it is between 1 and 2. That means the time is after 1 o'clock but it is not yet 2 o'clock.

Therefore the time is 1: 50p.m

3. What evening time is shown on the clock face below?



The time is 10: 10p.m

### Exercise

1. Write the morning time shown on the clocks below:

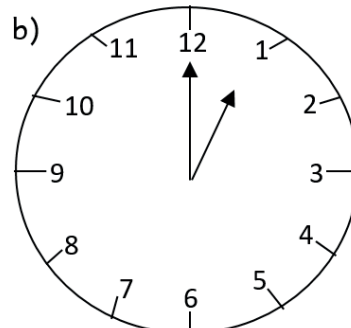
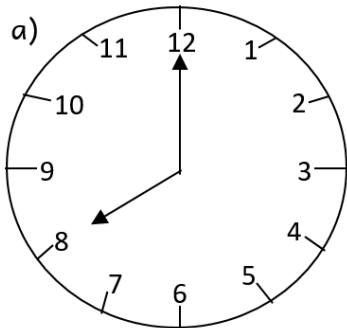

2. The time is 40 minutes past 4 o'clock. Show the time on the clock face below.



3. Write the afternoon time shown on the clock face below ( write your answer in Hindu- Arabic numerals)

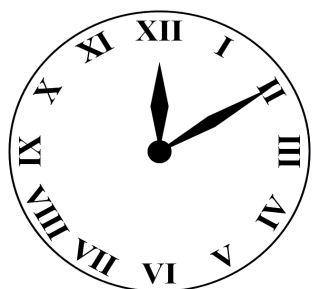

4. The time is "a quarter to 1 o'clock." Show the time on the clock face below

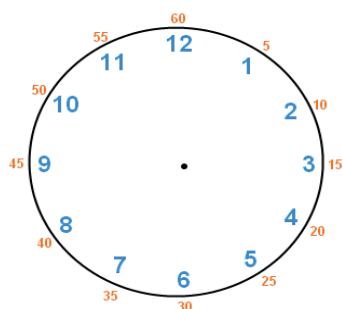

## Lesson 2: Telling time up to seconds

**In this lesson, you will:**

1. Recognize minutes and seconds.
2. Read and tell time verbally on the 12 hour clock.

**You will need:** a pencil, a pen, a book, a pair of compasses, a circular object

### Introduction

In the last lesson, you learnt how to tell time from a clock face where emphasis was put on the hour and minutes past the hour. In today's lesson you will include the seconds past the hour. This will help you to tell the exact time based on the smallest unit of time.

**Step 1 Activity.****Note:**

It takes about 1 second to jump up in the air or to snap your fingers. A second is a very short period of time. 1 minute = 60 seconds. A second hand goes around a clock face once every minute.

- Draw a clock face.
- Show 4: 00: 40 (40 seconds, 00 minutes past 4 o'clock) on the clock face

Your clock face should look like the one below:

**Step 2**

Look at the following example.

Write the time shown on the clock face below up to seconds



[www.laboratory-apparatus.com](http://www.laboratory-apparatus.com)  
[info@laboratory-apparatus.com](mailto:info@laboratory-apparatus.com)

The time is 2: 55: 31 (31 seconds, 55 minutes past 2 o'clock)

2. What time is shown on the watch below?



The time is 7:51:04 (4 seconds, 51 minutes past 7 o'clock.)

**Exercise.**

Write the time shown using hour, minutes and seconds.



2. What time is shown on the watch below?



## Lesson 3: Expressing hours as minutes

**In this lesson, you will:**

1. Convert hours to minutes.
2. Construct sentences involving phrases of time.
3. Convert minutes to hours.

**You will need:** a pencil, a pen, a book.

### Introduction

In the previous lesson you learnt how to read and tell time using the 12- hour clock. In today's lesson, you are going to learn how to change hours to minutes and vice versa. This topic will enable you to develop effective communication skills which will help you to use what you know about minutes and hours to tell time.

### Step 1

**Think about the following:**

- ✓ How many minutes are in 1 hour?
- ✓ How many seconds are in 1 minute?
- ✓ How many hours are in 1 day?

Well, we know that you must have got the following answers:

- 1 hour = 60 minutes
- 1 minute = 60 seconds
- 1 day = 24 hours.

### Step 2

Look at the following examples

1. How many minutes are there in 5 hours?  
 1 hour = 60 minutes

$$\begin{aligned} 5 \text{ hours} &= 60 \text{ minutes} \times 5 \\ &= 300 \text{ minutes} \end{aligned}$$

Therefore there are 300 minutes in 5 hours

2. Change  $2\frac{1}{4}$  hours to minutes

In this number you need to change  $2\frac{1}{4}$  hours to an improper fraction

$$\begin{aligned} \frac{(4 \times 2) + 1}{4} &= \frac{8 + 1}{4} \\ &= \frac{9}{4} \text{ hours} \end{aligned}$$

$$1 \text{ hour} = 60 \text{ minutes}$$

$$\begin{aligned} \frac{9}{4} \text{ hours} &= \overset{15}{\cancel{60}} \text{ minutes} \times \frac{9}{\cancel{4}} \\ &= 135 \text{ minutes} \end{aligned}$$

### Recall!

When changing hours to minutes, just multiply the given hours by 60 minutes.

3. Change 180 minutes to hours.

$$60 \text{ minutes} = 1 \text{ hour}$$

$$\begin{aligned} 180 \text{ minutes} &= \frac{180}{60} \text{ minutes} \\ &= 3 \text{ hours} \end{aligned}$$

$$\begin{array}{r} 3 \\ \underline{-180} \\ 1 \quad \underline{-60} \end{array}$$

**Note:** When changing minutes to hours simply divide the given minutes by 60 minutes

### Step 3

#### Exercise

- Express the following hours as minutes
  - 3 hours
  - 4 hours
  - 8 hours
  - $3\frac{1}{2}$  hours
  - $5\frac{1}{3}$  hours
- The village meeting lasted for  $2\frac{2}{3}$  hours. How many minutes did it last
- A Mathematics examination lasted for  $2\frac{1}{2}$  hours. Express the time in minutes.
- Change the following minutes to hours
  - 120 minutes
  - 240 minutes
  - 360 minutes
  - 90 minutes
- A Mathematics examination lasted for 150 minutes. Express the time in hours

## Lesson 4: Finding duration

In this lesson, you will:

- Work out **the** duration **if** given two points
- Construct sentences involving phrases of time.

You will need: a pencil, a book, a pen

### Introduction

Duration is the time spent on something.

To find duration, subtract the time an activity started from the time an activity ended. This topic will help you to plan ahead when you know about how long something will take.

#### Step 1: Example 1

- A village meeting started at 8:00a.m and ended at 10:00a.m. What was the duration of the meeting?

Subtract the time the meeting started from the time it ended.

$$\begin{array}{r} \text{Ending time} \quad 10:00\text{a.m} \\ \text{Starting time} \quad -8:00\text{a.m} \\ \hline 2\text{h } 00\text{min.} \end{array}$$

The duration of the meeting was 2 hours.

#### Example 2

It started raining at 7:00a.m and ended at 10:00a.m. For how long did it rain?

Subtract the starting time from the ending time

$$\begin{array}{r} \text{Ending time} \quad 10: 00\text{a.m} \\ \text{Starting time} \quad -7: 00\text{a.m} \\ \hline 3\text{h } 00\text{min} \end{array} \quad \text{Therefore it rained for 3hours.}$$

#### Example 3

A farmer went to the garden at 3: 30p.m and went back at 6: 45p.m. For how long was the farmer in the garden?

Ending time – starting time

$$\begin{array}{r} 6: 45\text{p.m} \\ -3: 30\text{p.m} \\ \hline 3\text{h } 15\text{min} \end{array} \quad \text{therefore the farmer dug for 3 hours 15 minutes.}$$

#### Example 4

Achan went to school at 7:00a.m and went back at 4:00p.m. How long was she at school?

- This duration crosses midday. So first subtract 7: 00a.m from midday and then add 4 hours as shown below

$$\begin{array}{r} 12: 00 \\ -7: 00 \\ \hline 5\text{h } 00\text{min} \end{array} \qquad \begin{array}{r} 5: 00 \\ + 4: 00 \\ \hline 9\text{h } 00\text{min} \end{array}$$

Therefore Achan was at school for 9 hours.

**Step 2****Exercise**

1. A meeting started at 8:00a.m and ended at 11:00a.m. How long did the meeting last?
2. The national prayers started at 2:00p.m and ended at 5:00p.m. For how long did it last?
3. A football match started at 4:00p.m and ended at 5:30p.m. For how long did it last?
4. A bus left Arua for Kampala at 5:00a.m and arrived at 6:00p.m. How long was the journey?
5. A p.5 pupil started digging at 7:30a.m and finished at 10:30a.m. Find the time the pupil took digging.

**Lesson 5: Time, distance and speed.****In this lesson, you will:**

1. Solve problems related to time, speed and distance.
2. Calculate speed, distance and time using simple word problems.

You will need: a pen, a pencil, a book

**Introduction.**

You have already learnt about time in the previous lesson. The distance travelled by a person, body or vehicle in a unit of time uses a particular speed. In this lesson you are going to learn about the relationship between these three ideas: speed, distance and time. Speed is basically how fast someone is moving.

In this lesson you are going to learn about the relationship between these three words: speed, distance and time.

- Distance means the part of the journey you cover while walking or running.
- Time is how long you take to travel a particular distance

**Step 1**

Opio walked a distance of 2km in 1 hour.

- a) What distance did he walk in 2 hours?
- b) What distance did he walk in 3 hours?
- c) What distance did he walk in 4 hours?

Well the answers are shown in the table below:

Distance in 1 hour	Time taken walking	Total distance
2km	1 hour	2km
2km	2 hours	4km
2km	3 hours	$2 \times 3 = 6\text{km}$
2km	4 hours	$2 \times 4 = 8\text{km}$

**Step 2**

From the above table to find distance, multiply speed by time that is:

Distance = speed X time (D = S X T)

**Look at the following examples**

1. Angel drove a car at a speed of 80km per hour for 3 hours. Find the distance she covered.

Note km/h can also be written as  $\frac{km}{h}$

Distance = speed X time

Distance =  $80 \frac{km}{h} \times 3 h$  — we cancel the hours, this leaves us with kilometres (km)

Distance = 240 km

2. Peter rode a bicycle at a speed of 20km per hour for  $2\frac{1}{2}$  hours. What distance did he cover?

You have to change  $2\frac{1}{2}$  hours to an improper fraction

$$\frac{(2 \times 2) + 1}{2} = \frac{5}{2} h$$

Distance = speed X time

Distance = 20km/h X  $2\frac{1}{2} h$

Distance =  $20 \frac{km}{h} \times \frac{5}{2} h$  Divide 20 by 2:  $20 \div 2 = 10$ ,

Distance = 50km                      10km X 5 = 50km

3. A bus travelling at a speed of 70km per hour left town X at 8:00a.m and reached town Y at 10:00a.m. Find the distance between the two towns

First find the time taken

10: 00a.m

-8: 00a.m

---

2h 00min

Time = 2hours

Distance = speed X time

Distance =  $70 \frac{km}{h} \times 2 h$

Distance = 140km

**Exercise**

1. A cyclist rode at a speed of 20km per hour for 4 hours. What distance did the cyclist cover?
2. A bus travelled from town X to town Y at a speed of 80 km per hour for 6 hours. What distance did it cover?



3. Mugisha travelled for  $3\frac{1}{2}$  hours at a speed of 60km per hour. What distance did he cover?
4. A bus travelling at a speed of 70km per hour left town M at 1:00p.m and arrived at town N at 6:00p.m. Find the distance between the two towns.

### Lesson 6: Finding time

#### In this lesson, you will:

1. Solve problems related to speed, time and distance.
2. Construct sentences involving phrases of time.

You will need: a pen, a book, a pencil

#### Introduction

In the previous lesson you learnt about finding distance, in today's lesson you are going to learn about finding time.

#### Step 1:

The distance between two towns is 24km. Akena travelled between the two towns using different means as shown in the table below.

Means	Distance	Speed	Time
Foot	16km	2km/h	8 hours
Bicycle	16km	8km/h	2 hours

#### From the table;

##### On foot:

2km are covered in 1 hour

16km are covered in  $(16 \div 2) = 8$  hours

##### By bicycle

8km are covered in 1 hour

16km are covered in  $(16 \div 8) = 2$  hours

From the above working, we note that to find time, just divide distance by speed, that is

$$\text{Time} = \text{Distance} \div \text{speed. } (T = \frac{D}{S})$$

This topic will help you to learn to plan a head when you know about how long something will take. To understand this better, try the activity below.

#### Step 2

A cyclist travels 20km in 1 hour. At this rate how long will the cyclist take to travel 60km?

Well, no matter what method you use, you must get the answer shown below.

20km represent 1 hour

20km represent 1 hour

20km represent 1 hour

---

60 km represent 3 hours

The cyclist will take 3 hours

**Step 3.**

Look at the following example

1. Mary travelled a distance of 100km at a speed of 50km per hour. What time did she take?

$$\text{Time} = \text{Distance} \div \text{speed}$$

$$\text{Time} = 100\text{km} \div 50\text{km/h} \text{ (km} \div \text{km} = 1)$$

$$\text{Time} = \frac{100}{50} \text{ hours}$$

$$\text{Time} = 2 \text{ hours}$$

**Exercise**

1. The distance from town X to town Y is 240 km. How long will a car take to travel the distance at a speed of 80 km per hour?
2. A motorist covered a distance of 140 km at a speed of 70km per hour. How long did the journey last?
3. Find the time that is needed to cover a distance of 600km at a speed of 100km per hour
4. Shafik travelled a distance of 180km at a speed of 60km per hour. Find the time taken to travel the distance

**Lesson 7: Finding speed**

**In this lesson, you will:**

1. Solve problems related to speed, time and distance.
2. Construct sentences involving phrases of time.

**You will need:** a pencil, a pen, a book

**Introduction**

In the previous lessons you learnt about finding distance and time. In today’s lesson you are going to learn how to find speed.

**Step 1**

- The distance between Jinja and Kampala is 80 km. A tractor took 2 hours to travel the distance.
- Divide the distance covered by the time taken.
- $80\text{km} \div 2 \text{ h} = 40 \text{ km/h}$ .
- The distance (80km) divided by the time (2h) gives you the speed of the tractor.

To find speed, divide distance by time, that is:

$$\text{Speed} = \text{Distance} \div \text{Time. } (S = \frac{D}{T} )$$

The knowledge of speed helps you to estimate the travelling time between two places so that you are not late.

**Step 2**

Look at the following example

1. Nabirye covered a distance of 150km in 3 hours. Find her speed

$$\text{Speed} = \text{Distance} \div \text{Time}$$

$$\text{Speed} = 150\text{km} \div 3\text{h}$$

$$\text{Speed} = \frac{150 \text{ km}}{3 \text{ h}}$$

$$\text{Speed} = 50\text{km/h}$$

2. At what speed should a driver travel to cover a distance of 280km in  $3\frac{1}{2}$  hours?

Change  $3\frac{1}{2}$  hours to an improper fraction

$$\frac{(2 \times 3) + 1}{2} = \frac{7}{2} \text{ hours}$$

$$\text{Speed} = \text{Distance} \div \text{Time}$$

$$\text{Speed} = 280\text{km} \div 3\frac{1}{2} \text{ h}$$

$$\text{Speed} = 280\text{km} \div \frac{7}{2} \text{ h}$$

$$\text{Speed} = 280 \text{ km} \times \frac{2}{7} \text{ h}$$

$$\text{Speed} = 80 \text{ km/h}$$

**Exercise**

1. A car took 5 hours to travel a distance of 400km. At what speed was it travelling?
2. A cyclist takes 3 hours to cycle a distance of 60km. Find the cyclist's speed.
3. The distance between town P and town Q is 250km. Find the speed of a motorist who travelled the distance in 5 hours
4. Nabufu travelled a distance of 200km in  $2\frac{1}{2}$  hours. Find her speed?
5. Namono took 4 hours to travel a distance of 280km. What was her speed?

## Term Three

### TOPIC: MONEY

#### LESSON 1: Completing tables of bills

**In this lesson, you will;**

- Find the unit price of items using total **cost** and quantity.
- Find the cost using quantity and unit cost.
- Work out the quantity using total cost and unit cost.
- Complete a shopping bill.

**You will need:**

An exercise book, a pen, a pencil and a ruler.

**Introduction:**

In primary four you were introduced to bills. Sometimes you need to prepare your bill in table form. This makes it easy for you or your parents to understand the shopping bill. In order to know how much has been spent on an item.

**Always remember.**

In order to get the total cost, we multiply the quantity (number of items) by the unit cost (Cost of one item).

To get the unit cost, we divide the total amount by the quantity.

To get the quantity, we divide the total amount by the unit cost.

#### Step 1

**Activity**

Prepare a bill for the items below.

2 books **at** sh 1,000 each.

3 kilogrammes of sugar **at** sh 30000 each.

5 pens **at** sh 500 each.

2 geometry sets for sh. 1,500 each.

(a) Draw a table similar to the one below.

ITEM	QUANTITY	UNIT COST	TOTAL COST
Books	2	Sh. 1,000	.....
Sugar	3kg	Sh. 3,000	.....
Pens	5	Sh. 500	.....
Geometry set	2	Sh. 1,500	.....
	TOTAL		.....

(b) To find the total cost for each item, multiply the quantity by the unit cost as shown below:

$$\text{Books} \quad 2 \times 1000 \quad = \quad \text{sh.}2000$$

$$\text{Sugar} \quad 3 \times 3000 \quad = \quad \text{sh.}6000$$

$$\text{Pens} \quad 5 \times 500 \quad = \quad \text{sh.}1000$$

$$\text{Geometry set} \quad 2 \times 1,500 \quad = \quad + \text{sh. } 3000$$

c) Enter the total cost in the table.

### Step 2

#### Study the example below

1. The bill below was prepared by a primary five pupil. Use it to answer the questions that follow.

a) Complete the bill

ITEM	QUANTITY	UNIT COST	TOTAL COST
Omo	2 sachets	Sh. 1,000 each	<u>Sh. 2,000</u>
Maize Flour	3kg	Sh. 3,000 per kg	Sh. 9,000
Chicken	2 birds	<u>Sh. 15,000</u> per bird	Sh. 30,000
		Total	<u>Sh. 41,000</u>

$$\begin{aligned} \text{(a) Omo} \quad \text{quantity} \times \text{unit cost} &= \text{Total} \\ 2 \quad \times \quad \text{sh. 1,000} &= \text{sh. 2,000} \end{aligned}$$

$$\begin{aligned} \text{Maize flour} \quad \text{quantity} &= \frac{\text{Total cost}}{\text{Unit cost}} = \frac{\text{sh. 9,000}}{\text{sh. 3,000}} = 3 \end{aligned}$$

$$\begin{aligned} \text{Chicken} \quad \text{unit cost} &= \frac{\text{Total cost}}{\text{Quantity}} = \frac{\text{sh. 30,000}}{2} = \text{sh. 15,000} \end{aligned}$$

(b) After all the above working, complete the table above.

#### Exercise

Study and complete the shopping bill below.

ITEM	QUANTITY	UNIT PRICE	AMOUNT
Bananas	3 bunches	Sh. 10,000 each	_____
Cassava Flour	5 kg	_____	Sh. 5,000
Beans	_____ kg	Sh. 3,000 per kg	Sh. 9,000
Irish Potatoes	2 tins	Sh. 15,000	_____
		TOTAL	sh. _____

### Lesson 2: Buying and Selling using Ugandan money.

#### In this lesson, you will:

Find the cost of more than one item.

Work out total cost of items bought.

#### You will need:

An exercise book, a pen and a pencil.

#### Introduction:

In primary four you have learnt about shopping bills. A shopping bill helps you to know how much money you have spent on an item and the total cost.

In this lesson, you are going to learn buying and selling using Uganda money.

Remember Uganda money consists of notes of sh.1, 000, sh. 2,000, sh.5, 000, sh.10, 000, sh.20, 000 and sh.50, 000. It also consists of coins of sh.100, sh.200, sh.500 and sh.1000.

**Step 1:**

**Activity**

In your exercise book prepare your shopping bill for the items your family bought on any day this week.

**Study the following example**

Okello went to a shop and bought the items below:

2kg of sugar at sh. 3200 per kg

3kg of rice at sh. 4000 per kg

1 litre of cooking oil at sh. 3000 per litre.

a) How much money did Okello spend altogether?

ITEM	UNIT COST	TOTAL COST
2kg of sugar	sh. 3200	$2 \times \text{sh. } 3200 = \text{sh. } 6,400$
3kg of Rice	Sh. 4,000	$3 \times \text{sh. } 4,000 = \text{sh. } 12,000$
1 litre of cooking oil	Sh. 3,000	<u>Sh. 3,000</u>
		<u>Sh. 21,400</u>

**Example 2**

Kataike had sh. 20,000 and bought items for sh.11, 400. How much money did she take back home?

Sh. 20,000

Sh. 11,400

— Sh. 8,600

The money which Kataike took back home is called change.

**Exercise**

Jalia went to a shop and bought the following items.

2 trays of eggs at sh. 10,000 each tray.

3 bars of soap at sh. 3,000 per bar.

1 kg of sugar at sh. 3,200 per kg.

A) How much money did Jalia spend altogether?

b) If she went with sh. 50,000, how much money did she take back home?

**Lesson 3: Finding profit and loss**

**In this lesson, you will:**

- Find profit when buying and selling price is given.
- Find loss when buying and selling price is given.

**You will need:**

A Pen, a pencil, an exercise book and a ruler.

**Introduction:**

Sometimes traders get a loss or a profit when they sell the items.

A profit is the money you get when the selling price is higher than the buying price.

A loss is the money you get when the buying price is higher than the selling price.

Learning Profit and loss helps you to manage your business properly when you grow up.

So you notice that when you buy an item at a lower price and sell it at a higher price, you get a profit

**Step 1:****Activity**

a) Arafat buys sugar at sh. 2,800 and sells it at sh. 3,000.

b) Asia buys sugar for sh. 3,000 and sells it at sh. 2,500.

Who got a profit? (Give a reason)

Who made a loss?

**Step 2****Study the example below.**

A trader bought a pen for sh.1,000 and sold it at sh.1,500. Find his profit.

Cost price (buying price) is sh. 1,000

Selling price is sh. 1,500

Profit = selling price – cost price.

= sh. 1,500

- sh. 1,000

Sh 500

Therefore his profit was sh.500.

**Example 2**

Kalete bought a handkerchief for sh. 2,000 and later sold it at sh. 1,800. Find his loss.

Cost price (buying price) is sh. 2,000.

Selling price is sh. 1,800.

Loss = cost price – selling price.

= sh. 2,000

- Sh. 1,800

Sh. 200

Therefore the loss was sh.200.

**Exercise**

1. Jacinta bought a dress for sh. 80,000 and sold it at sh. 85,000. What was her profit?
2. Agaba bought a goat for sh. 95,000 and sold it at sh. 107,000. What profit did he get?
3. A shopkeeper sold a bag of sugar at sh.50, 000. If he bought it at sh.40, 000, Find his profit.
4. A pair of shoes cost sh. 25,000. It was later sold at sh. 16,500. What was the loss?

5. A trader bought items for sh.560, 500 and sold them at sh.549, 000. Find the loss.

**Lesson 4: Finding the selling price when the loss or the profit is given.**

**In this lesson, you will:**

- Find the selling price when the loss and the cost price is given.
- Find the selling price when the profit is given.

**You will need:**

An exercise book, a pen and a ruler.

**Introduction:**

In the previous lesson, you learnt how to find profit and loss. You know the meaning of profit and loss. In this lesson, you are going find selling price or cost price when profit or loss is given. This will help you to find out whether you are making progress in a business or not. It helps you to take action early enough when you find a business is not progressing.

**Step 1**

**Activity:**

A boy bought a ball at sh.12000. He sold it at a loss of sh. 2000.  
What do you do to find the price at which he sold the ball?

**Step 2:**

- You notice that in order to get the selling price when given the loss, you subtract the loss from the buying price.
- If you have got profit, add it to the buying price in order to get the selling price.

**Step 3:**

Study the example below.

- (a) Wasswa bought a sweater for sh.20,000 and sold it at a loss of sh.2,000.

Find the selling price of the sweater.

Loss = sh.2,000

Buying price = sh.20,000

Selling price = Buying price – loss

= sh. 20,000

- Sh. 2,000

Sh. 18,000

- (b) Nakate bought a tin of millet flour for sh.36,000. She then sold the millet and made a profit of sh.3,500. At what price did Nakato sell the millet Flour?

Profit = sh.3, 500

Buying price = sh.36,000

Selling price = buying price + profit.

= sh. 36,000

+sh. 3,500

Sh. 41,500



**Exercise**

1. A man bought a radio **at** sh.15,000. He then sold it at a loss of sh.2,000. What was the selling price?
2. Odyeke bought a goat **at** sh.125,000 and sold it at a loss of sh. 5,000. Find the selling price.
3. Mugisha bought a calf **at** sh.450,000 and sold it at a profit of sh.40,000. Find its selling price.
4. A girl bought a phone **at** sh.70,000 and sold at a loss of 15,000. Find the selling price of the phone.
5. Find the selling price of a cup which was bought **at** sh.15,000 and sold at a profit of sh.1,000.

**Lesson 5: Find buying price when profit or loss is given****In this lesson, you will:**

- Find the buying price when profit is given.
- Find the buying price when loss is given.

**You will need:**

- An exercise book and a pen.

**Introduction:**

In the previous lesson, you learnt how to find selling price when given loss or profit. In this lesson, you are going to learn how to find **the** buying price when profit or loss is given.

**Step 1****Activity**

A shopkeeper made a loss of sh.3000 after selling face masks for sh.14000.  
What do you do to find the price at which the shopkeeper bought the face masks?

- You notice that in order to get the buying price when given the loss, you add the loss **to** the selling price.
- If you have got profit, then subtract it from the selling price in order to get the buying price.

**Step 2:**

Study the example below.

(a) Kasim sold a crate of soda for sh.24,000 and made a loss of sh.2000. Find how much he bought the soda.

Selling price	sh.24,000
Loss	+ <u>sh. 2,000</u>
Buying price	<u>Sh. 26,000</u>

(b) Asio sold a cow for sh.700,000 and made a profit of sh.250,000. Find the cost price of the cow.

Selling price	sh. 700,000
Profit	- <u>sh. 250,000</u>
Cost Price	<u>sh. 450,000</u>

**Now try this exercise**

1. A shopkeeper sold items for sh.70,000 and made a loss of sh.8,000. Find the buying price of the items.
2. Chemtai sold a cupboard for sh.90,000 and made a profit of sh.12,000. Find the cost price of the cupboard.
3. Nankinga sold 6 cartons of books for sh.320,000 and made a loss of sh.7,000. Calculate the cost price of the books.
4. A trader sold a table for sh.100,000 and made a profit of sh.20,000. Work out the buying price of the table.
5. Tusabe sold a cock for sh.45,000 and made a loss of sh.7,000. Find the price at which Tusabe bought the cock.

## TOPIC: LENGTH, MASS AND CAPACITY

### LESSON 1: Converting metres to centimeters and centimeters to millimeters.

**In this lesson, you will:**

- Convert metres to centimeters.
- Convert centimetres to millimeters.

**You will need:**

A string, a ruler, an exercise book and a pen.

**Introduction:**

In primary four, you estimated length. You also learnt the units for measuring length, for example, metres, centimetres and millimetres.

In this lesson, you are going to change metres to centimeters and centimeters to millimetres. Centimetres and metres are used to measure short length, for example, the length of a book, length of a desktop, height of a person. On the other hand, metres are used to measure longer lengths, for example, the length of a playground, and courtyard.

**Step 1****Activity**

- Stand beside the wall of your house and mark where your head has stopped. That is your height.
- Use a string to measure your height.
- Now measure the length of the string in centimeters.
- You have now got your height in centimeters.

**Step 2****Study the examples below****Example 1**

Change 7m to cm.

$$1\text{m} = 100\text{cm}$$

$$7\text{m} = (7 \times 100)\text{ cm}$$

$$7\text{m} = 700\text{ cm}$$

**Example 2.**

Express 9 centimetres as millimetres

$$1\text{cm} = 10\text{mm}$$

$$9\text{cm} = 9 \times 10\text{mm}$$

$$9\text{cm} = 90\text{mm}$$

**Example 3.**

The length of our courtyard is 0.7m. Change the length to cm.

$$1\text{m} = 100\text{cm}$$

$$0.7\text{m} = \left(\frac{7}{10} \times 100\right)\text{ cm}$$

$$0.7\text{m} = 70\text{cm}$$

**Exercise**

1. Change 2 metres to centimeters.
2. Change 15m to cm.
3. Express 19cm as mm.
4. Musoke bought a piece of wood of length 8metres. Convert the length to centimeters.
5. The height of our table is 90cm. Change this to millimeters.
6. Express these as cm.
  - a) 15m
  - b) 7.8m

## LESSON 2: Converting centimeters to metres and millimetres to centimetres

### In this lesson, you will:

- Change centimeters to metres.
- Change millimeters to centimeters.

### You will need:

- A string or a stick , a ruler , an exercise book and a pen.

### Introduction:

In the previous lesson, you learnt how to change from metres to centimetres and from centimetres to millimeters. You multiplied metres by 100 to get centimetres, and multiplied centimetres by 10 to get millimeters.

In this lesson, you are you are going to learn how to change from smaller units to bigger units by dividing. When you are changing from centimetres to metres you divide by 100 and when are changing millimeters to centimetres we divide by 10.

### Step 1

#### Activity

Use a rectangular sheet of paper to fill the table below.

Estimate in	Actual length
_____ centimetres	_____ metres
_____ millimetres	_____ centimeters

**Remember**  $100\text{cm} = 1\text{m}$

$10\text{mm} = 1\text{ cm}$

### Step 2

Study the examples below

#### Example 1

Change 700cm to metres.

$$100\text{cm} = 1 \text{ metre.}$$

$$1\text{cm} = \frac{1}{100} \text{ metres}$$

$$700\text{cm} = (700 \times \frac{1}{100}) \text{ metres.}$$

$$\underline{700\text{cm} = 7\text{m}}$$

#### Example 2.

Convert 5,700cm to m.

$$100\text{cm} = 1\text{ m}$$

$$1\text{cm} = \frac{1}{100}\text{ m}$$

$$5,700\text{cm} = \frac{1}{100} \times 5700\text{ m}$$

$$5,700\text{ cm} = 57\text{m}$$

**Example 3.**

The length of an exercise book is 200mm. Find the length in cm.

$$10\text{mm} = 1\text{ cm}$$

$$1\text{mm} = \frac{1}{10}\text{ cm}$$

$$200\text{mm} = \frac{1}{10} \times 200\text{ cm}$$

$$200\text{mm} = 20\text{ cm.}$$

**Exercise**

**You can now do this exercise.**

1. Change 400cm to m.
2. Express 900cm as metres.
3. Solome used 300cm of cloth to make masks to prevent spread of covid 19. Change this to metres .
4. Change 50mm to cm.
5. A carpenter measured 600mm of wood to make a stool. Change this to centimeters.
6. Convert 200 millimetres to centimetres.

**Lesson 3. Finding the perimeter of rectangles and squares.**

**In this lesson, you will:**

- Find the perimeter of rectangles and squares.
- Solve word problems involving perimeter of rectangles and squares.

**You will need:**

- Cut outs of rectangles, a ruler, a string, an exercise book, a pencil and a pen.

**Introduction:**

In Primary four, you learnt about perimeter of shapes. Perimeter refers to the distance round a given closed figure.

Perimeter can be measured in millimeters, centimetres or metres.

In this lesson, you are going to find the perimeter of rectangles and squares.

Perimeter of rectangles is important because it is perimeter which we use when we are constructing perimeter walls around houses or even putting a fence around our gardens.

**Step 1**

**Activity**

- Look around your home. You can see a rectangular object. Get near it and measure the distance round it using a ruler.
- Record the measurements in a table like the one below.

Length	width	length	width	Total
_____	_____	_____	_____	_____
—	—	—	—	—

- When you add the measurements of that shape, then you have got its perimeter.

**Step 2.**

Study the examples below.

**Example 1**

Find the perimeter of the figure below.

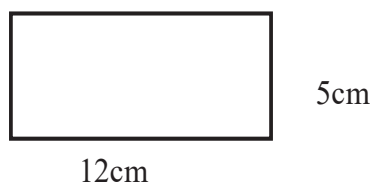

$$\begin{aligned}
 \text{Perimeter} &= L + W + L + W \\
 \text{Perimeter} &= 12\text{cm} + 5\text{cm} + 12\text{cm} + 5\text{cm} \\
 &= 17\text{cm} + 17\text{cm} \\
 &= 34\text{cm}.
 \end{aligned}$$

**Example 2.**

Find the perimeter of a square of side 7cm.

**Step 1:**

Draw a sketch of a square with 7cm.

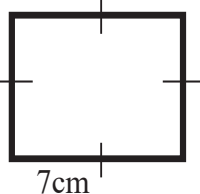

**Step 2:** Write the formula

Perimeter of a square = sum of all its 4 sides.

**Step 3:**

Work out the perimeter.

$$\begin{aligned}
 \text{Perimeter} &= S + S + S + S \\
 &= 7\text{cm} + 7\text{cm} + 7\text{cm} + 7\text{cm} \\
 &= 28\text{cm}.
 \end{aligned}$$

**Example 3**

A rectangular playground has a length of 13metres and a width of 9metres.

Work out its perimeter.

**Step 1:**

Draw a rectangle measuring 13metres by 9metres.

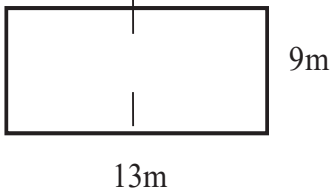
**Step 2:**

Write the formula.

$$\text{Perimeter} = L + W + L + W$$

**Step 3:**

Work out the perimeter

$$\text{Perimeter} = 13\text{m} + 9\text{m} + 13\text{m} + 9\text{m}$$

$$P = 22\text{m} + 22\text{m}$$

$$P = 44\text{m}$$

**Example 4**

The side of a square garden is 25metres.

Work out the perimeter of the garden.

**Step 1:**

Draw a sketch of the garden.

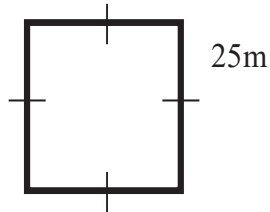
**Step 2**

We write the formula

$$\text{Perimeter} = 4 \times \text{side}$$

**Step 3**

Work out the perimeter.

$$\text{Perimeter} = (4 \times 25) \text{ m}$$

$$\text{Perimeter} = 100\text{m}.$$

**Exercise.**

1. Work out the perimeter of the figures below.

a)

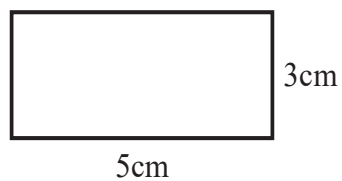

b)

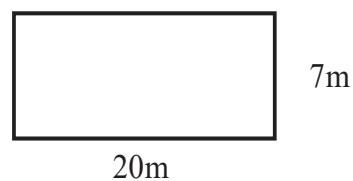

2. Find the perimeter of the figures below.

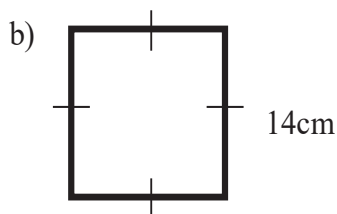
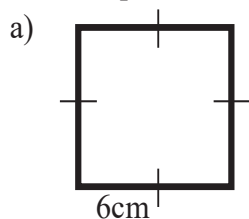

3. Find the perimeter of a rectangular box top of length 64cm and width 35cm.

4. A rectangular flour garden has a length of 15metres and a width of 8metres. Work out its perimeter.

#### Lesson 4. Find the perimeter of the triangles.

In this lesson, you will:

- Work out the perimeter of triangles.
- Solve word problems involving perimeter of triangles.

You will need:

- Cut outs of triangles, a ruler, a string, an exercise book, a pencil and a pen.

**Introduction:**

In primary four, you learnt about shapes and a triangle was one of them. Using a triangular cutout, you notice that a triangle has 3 sides. In order to find the perimeter of a triangle, you will add the lengths of the 3 sides. The total of the 3 sides is the perimeter of that triangle.

#### Step 1

**Activity**

- Get a cutout of a triangle and a ruler.
- Measure the three sides of the triangular cutout using your ruler.
- Record the measurements.
- Add to the measurements.
- The total of the measurements is the perimeter of that triangle.

#### Step 2

**Study these examples.**

**Example 1**

Find the perimeter of the triangle below.

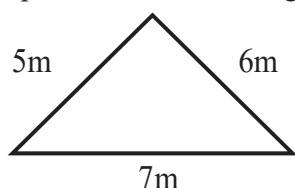

$$\begin{aligned} \text{Perimeter} &= \text{sum of the 3 sides.} \\ &= 7\text{m} + 6\text{m} + 5\text{m} \\ &= 18\text{m.} \end{aligned}$$



**Example 2**

Martin measured their triangular table top and recorded the measurements; 34.3cm, 40.2cm and 36.1cm. Find the perimeter of the table top.

Step 1:

Draw a sketch of the triangle.

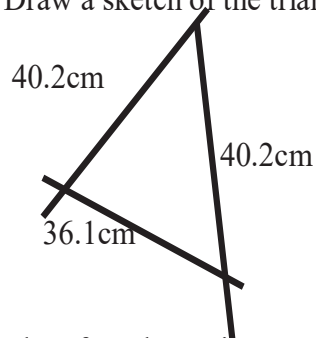

Step 2: write the formulae.

Perimeter = side + side + side.

Step 3: Work out the perimeter.

$$P = 34.3\text{cm} + 40.2\text{cm} + 36.1\text{cm}$$

$$\begin{array}{r} \text{Perimeter} = 34.3\text{cm} \\ \quad \quad \quad 40.2\text{cm} \\ \quad \quad \quad + 36.1\text{cm} \\ \hline \quad \quad \quad 110.6\text{cm} \end{array}$$

Therefore the perimeter of the table top is 110.6cm

**Exercise:**

1. Find the perimeter of the triangles below.

a)

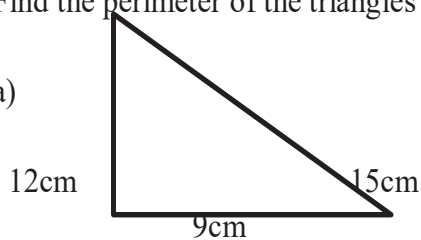

b)

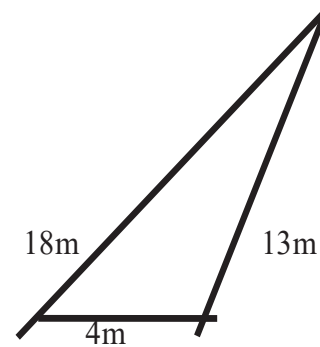

- Work out the perimeter of a triangular flower garden of side 11 metres, 18metres and 7metres.
- A triangular tray measures 60cm, 50cm and 44cm. Find the perimeter of the tray.
- Work out the perimeter of an equilateral triangle of side 7.5cm.
- A triangular carpet measures 17m by 12m by 15m. Find the perimeter of the carpet.

**Lesson 5: Area of a rectangle.****In this lesson, you will:**

- Find the area of a rectangle.
- Solve word problems involving finding area of a rectangle.

**You will need:**

- An exercise book, cutouts of rectangles, mats, a pen and a pencil.

**Introduction:**

In primary four you learnt about finding the area by counting squares in a plain figure.

Remember the space occupied by a plain figure is its area.

Area helps you to know, for example, the size of land you will use for building and farming.

In this lesson, you will find area of a rectangle without counting the squares.  
Remember area is measured in square units.

**Step 1**

**Activity**

- Find the area of the figure below.



- By counting there are 12 square units.
- 6 square along the length and 2 squares along the width.
- If multiply 6 squares by 2 square you get 12square units.  
6 squares  $\times$  2 square = 12 square units.

You are now going to find **the** area without counting squares.

**Step 2**

**Study the examples below.**

**Example 1**

Find the area of a rectangle whose length is 8cm and width 4cm.

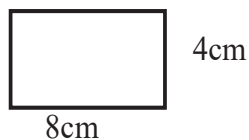

$$\begin{aligned} \text{Area} &= \text{length} \times \text{width} \\ &= 8\text{cm} \times 4\text{cm} \\ &= 32\text{cm}^2 \end{aligned}$$

You notice that in order to find area of a rectangle, multiply the length by the width.

**Example 2**

A rectangular compound is 100m long and 70m wide. Work out the area of the compound.

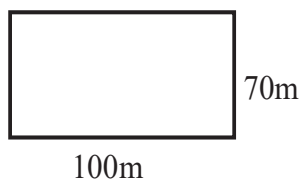

$$\begin{aligned} \text{Area} &= \text{length} \times \text{width} \\ &= 100\text{m} \times 70\text{m} \\ &= 7000\text{cm}^2 \end{aligned}$$

**Exercise**

1. Find the area of the figure below.

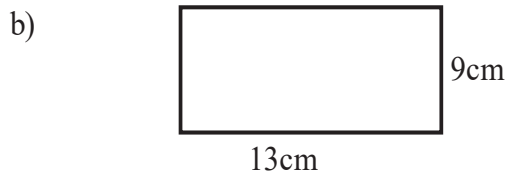
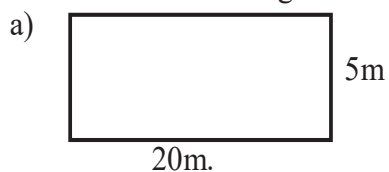

2. Find the area of a rectangle whose length is 19cm and width 10cm.
3. Find the area of a carpet of length 12m and width 8m.
4. The tabletop in our dining room is 120cm long and 75cm wide. Find the area of the tabletop.
5. Rita made a mat of length 180cm and width 60cm. Find the area of a mat.

## Lesson 6: Area of a square

### In this lesson, you will:

- Work out **the** area of squares.
- Solve problems involving finding the area of a square.

### You will need:

- Cut out squares, an exercise book, a pen and a pencil.

### Introduction:

You were introduced to shapes in primary four and a square is one of the shapes. You notice that a square has 4 equal sides. You also learnt how to find **the** area by counting the squares in a big square. In this lesson, you will work out the area of a square without counting the squares.

### Step 1

#### Activity

- Get a sheet of paper.
- Cut it into a square of side 4cm.
- Cut small squares of side 1cm.
- How many of them can cover the big square?
- You will notice that there are 16 small squares which will cover the big square.
- That is the area of the big square.

### Step 2

Study the examples below.

#### Example 1

Find the area of the figure below.

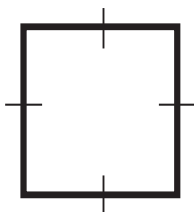

$$\begin{aligned}
 \text{Area} &= \text{side} \times \text{side} \\
 &= 9\text{cm} \times 9\text{cm} \\
 &= 81\text{cm}^2. \text{ (read this as square centimeters)}
 \end{aligned}$$

**Example 2**

The side of a square field is 24metres.  
Work out the area of the field.

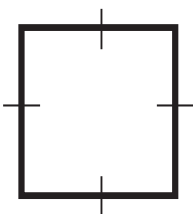

$$\begin{aligned} \text{Area} &= \text{side} \times \text{side} \\ &= 24\text{m} \times 24\text{m} \\ &= \underline{576\text{m}^2} \end{aligned}$$

Show detailed working.

$$\begin{array}{r} 24 \\ \times 24 \\ \hline 96 \\ +48 \\ \hline \underline{576} \end{array}$$

**Exercise**

1. Find the area of the figures below.

a)

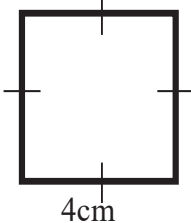

b)

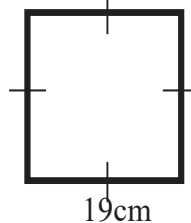
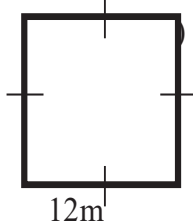

2. The side of a square garden is 27m. Find its area.
3. Work out the area of a square blackboard whose side is 70m.
4. The side of a square is 50m. Find its area.
5. A square piece of paper has a side of 23cm. find its area.

**Lesson 7: Find the area of a triangle.**

**In this lesson, you will:**

- Find the area of a triangle.
- Solve word problems involving area of a triangle.

**You will need:**

- A cutout of a rectangle, a cutter, a ruler, a pencil, an exercise book and a pen.

**Introduction:**

You learnt about shapes and a triangle was one of them. Using a rectangular cutout, you notice that when you divide the rectangle diagonally you will get two triangles which are equal. In order to find the area of a triangle, you will multiply the area of a rectangle by a half. In this lesson, you will find the area of a triangle using the formula of a triangle  $\frac{1}{2} \times \text{base} \times \text{height}$ . Area of a triangle helps welders and designers to know how much material they need to make, for example, clothes and crafts.

**Step 1:****Activity**

Look around and get a piece of a rectangular paper.

- Call it A
- Measure the length and width

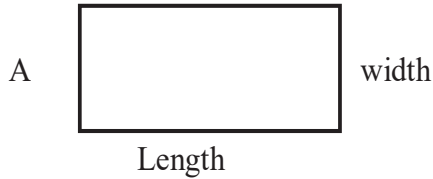

Cut it through its diagonal as shown below, call it B

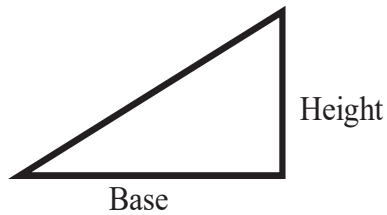

You will notice that triangle B is  $\frac{1}{2}$  of rectangle A.

If the area of the rectangle is  $30\text{cm}^2$

Then the area of the triangle is  $\frac{1}{2}$  the area of the rectangle

$$\begin{aligned} \text{Area of a triangle B} &= \frac{1}{2} \times 30 \text{ cm}^2 \\ &= 15 \text{ cm}^2. \end{aligned}$$

Since area of a rectangle = Length  $\times$  width

$$\begin{aligned} \text{Then Area of a triangle} &= \frac{1}{2} \times \text{base} \times \text{height} \\ &= 15\text{cm}^2 \end{aligned}$$

**Example 1**

Calculate the area of the triangle below

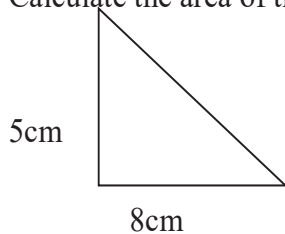

$$\begin{aligned} \text{Area of a triangle} &= \frac{1}{2} \times \text{base} \times \text{height} \\ &= \frac{1}{2} \times 8\text{cm} \times 5\text{cm} \\ &= 20\text{cm}^2 \end{aligned}$$

**Step 2**

**Example 2**

Find the area of a triangle whose base is 13cm and height 6cm.

$$\begin{aligned} \text{Area of a triangle} &= \frac{1}{2} \times \text{base} \times \text{height} \\ &= \frac{1}{2} \times 13\text{cm} \times 6\text{cm} \\ &= (13 \times 3) \text{ cm}^2 \\ &= 39\text{cm}^2 \end{aligned}$$

**Exercise**

1. Find the area of the triangles below.

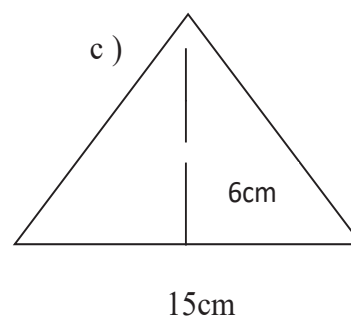
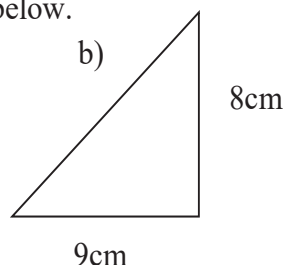
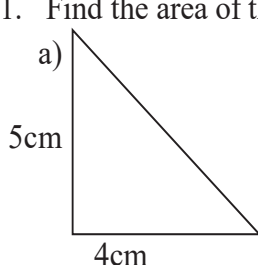

2. Find the area of a triangle whose base is 5cm and height 8cm.
3. The base of a triangular garden is 14m and height 7m. Find the area of the garden.
4. Work out the area of a triangle with the base 27m and height 5m.
5. Work out the area of a triangular board of base 14cm and height 8cm.
6. Diego made a triangular carpet of height 15cm and base 10cm. Find the area of the carpet.

**Lesson 8: Converting kilogrammes to grammes and vice versa**

**In this lesson, you will:**

- Change kilogrammes to grammes
- Change grammes to kilogrammes

**You will need:**

- An exercise book and a pen

**Introduction:**

Shop keepers sell essential items like salt, sugar, maize flour, cassava flour.

They use weighing stones to find the mass of the items.

You will notice that the common weighing stones used are for 1kg, 500g, 50g and 100g.

You can do this by observing some of the items your family buys from the shops.  
You will notice that  $1\text{kg} = 1000\text{g}$  and  $\frac{1}{2}\text{kg} = 500\text{g}$ .



### Step 1

#### Activity

- Look around your home and write the items that your family buys from the shop.
- Identify those that are measured in kilogrammes and those that are measured in grammes.
- Write the mass of the weighing stones you know.
- You will notice that 1kg, 2kg, 500g and 250g are common in our shops.

### Step 2

Now study the examples below.

#### Example 1

Express 5kg as grammes.

$$1\text{kg} = 1000\text{g}$$

$$5\text{kg} = (5 \times 1000)\text{g}$$

$$= 5000\text{g}.$$

#### Example 2

A boy bought 2000g of salt. What is this mass in kilogrammes?

$$1000\text{g} = 1\text{kg}$$

$$1\text{g} = \frac{1}{1000}\text{kg}$$

$$2000\text{g} = \frac{1}{1000} \times 2000\text{kg}$$

$$= 2\text{kg}$$

**Exercise**

1. Convert   a) 7kg to grammes.    b)  $2\frac{1}{2}$ kg   to grammes.
2. Change 30kg to grammes.
3. How many grammes make 15kg?
4. Opio bought 25kg of rice. How many grammes did he buy?
5. How many kilogrammes are in 4700grammes?
6. Joshua bought 9kg of meat. How many grammes did he buy?

**Lesson 9: Converting litres to milliliters and vice versa.****In this lesson, you will:**

- Convert litres to milliliters.
- Change milliliters to litres.

**You will need:**

- A half litre cup, a bucket and water.

**Introduction:**

In primary four, you were introduced to capacity. Capacity helps you to know the amount of something, for example, water, milk and other liquids a container can hold. In this lesson, you are going to change litres to milliliters and milliliters to litres.

Learning about capacity helps you to always use the right container for any amount, for example, jerrycans, plastic cups and bottles of water have different capacities.

**Step 1****Activity**

- You might be having a big jerrycan which you use for fetching water.
- The capacity of that jerrycan is 20litres.
- Write the capacity of the other jerrycans or containers you use at home.





**Step 1**

Study the examples below.

**Example 1**

Convert 9 litres to milliliters.

1 litre = 1000 milliliters.

9 litres =  $9 \times 1000$  milliliters  
= 9000 milliliters.

**Example 2**

Jamada bought 7000 millilitres of edible oil.

How many litres did he buy?

1000ml = 1 litre

1ml =  $\frac{1}{1000}$  litre

=  $\frac{1}{1000} \times 7000$  litres

= 7 litres.

**Exercise**

- Convert these to milliliters.
  - 3 litres.
  - 6 litres.
  - 5 litres
- A mother uses 4 litres of water every day.  
How many milliliters of water does she use?
- A trader sells 120 litres of paraffin a week.  
Express this capacity as milliliters.
- Catherine produces 15 litres of pineapple juice for sale. Change the capacity to milliliters.
- Change 2200 millilitres to litres.
- Express 5000ml as litres.

**TOPIC: INTEGERS****Lesson 1: Positive and negative integers**

In this lesson, you will:

- Draw a number line showing both negative and positive integers.
- Describe positive and negative integers.

You will need:

- Exercise book, pen and a pencil, and a ruler.

**Introduction:**

In everyday life we sometimes move forward and sometimes move backward. Moving forward is positive while moving backward is negative. There are other words which we use everyday like borrowing, subtracting, taking away, and removing which stand for negative. Then we also use words like profit, gain, adding, more, which stand for positive.

In this lesson, you are going to draw a number line and write positive and negative integers. An integer is a whole number which is either negative or positive.

You will notice that all negative integers are less than zero and all positive integers are greater than zero. Zero is the starting point and it is neither negative nor positive.

**Step 1**

**Activity**

Move outside your house. Move 5 steps forward, then move 5 steps backwards.

Forward movement is positive (+) +5

Backward movement is negative (-) -5

Draw a number line like the one below to show the 5 positive steps and the 5 negative steps.

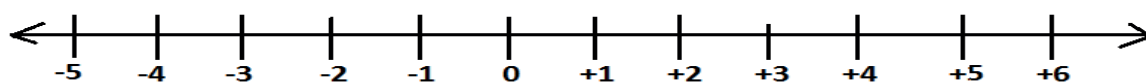

Left (backward)

Right (forward)

This is a number line. It is a line with numbers.

- The right has positive integers.
- The left has negative integers.
- 0 is neither positive nor negative. It is the starting point.
- Using the number line that you have drawn, move 5 steps to the right of 0. Name the integer where you have stopped.

Then now stand at 0 and move 5 to the left. Name the integer where you have stopped.

**Step 2**

**Study this example**

Which integer is 3 steps to the left of zero?

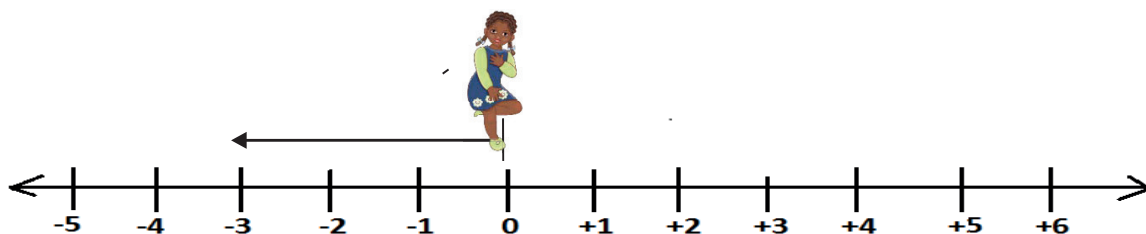

You will stand at zero facing your right. Then move backwards 3 steps from zero. You will now be at -3.

So the integer is -3.

Start from zero and count 3 steps backwards.

1. On the number line below, which integer is 3 steps to the right of  $-2$ ?

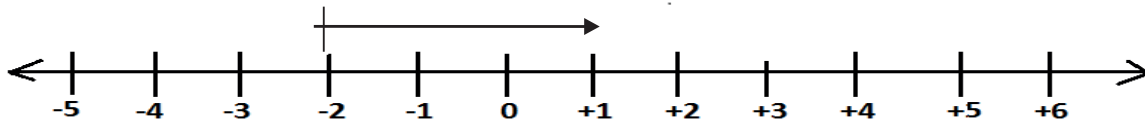

When you stand at  $-2$  and move 3 steps forward, you will be at  $+1$ . Therefore the integer 3 steps to the right of  $-2$  is  $+1$ .

$+1$  (count 3 steps from  $-2$ )

### Exercise

Use a number line to answer the questions below.

1. What name is given to integers which are to the left of zero?
2. Name the integers to the right of zero.
3. Which integer is five steps to the left of  $+5$ ?
4. Write the first 5 negative integers.
5. Write the first 4 positive integers?
6. Which integer is three steps to the right of  $-3$ ?
7. How many integers are there from negative  $-3$  to  $-7$ ?
8. Write the integers between 0 and  $+4$ .

## Lesson 2: Ordering and comparing negative and positive integers on a number line.

**In this lesson, you will:**

- Arrange integers in ascending order
- Compare negative and positive integers.

**You will need:**

- An exercise book, a pen and a pencil.

**Introduction:**

In the previous lesson, you learnt about positive and negative integers. You noticed that positive integers are greater than negative integers.

All negative integers are less than zero and positive integers are greater than zero. In order to compare integers, you will use a number line.

Integers to the left are always less than integers to the right. In this lesson, you are going to compare integers in order of size.

Today you are going to use the word descending order to mean from greatest to the lowest and ascending order to mean from lowest to greatest.

Remember the symbols

< is less than  
 > is greater than  
 = is equal to.

**Step 1**

**Activity**

- Note that integers to the left are less than those to the right.
  - Integers to the right are greater than those to the left.
- Let us study the number line below and arrange +4, -2, 0, -5, +3 in descending order.

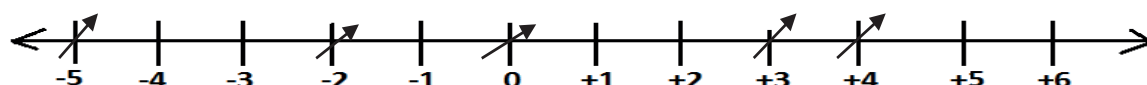

- Compare the integers before you arrange them.
- You will notice that positive 4 is greater than positive 3 and positive 3 is greater than 0.
- 0 is greater than -2.
- Therefore the answer in descending order, from the right to the left is +4, +3, 0, -2, -5

**Step 2**

Now you are going to arrange in ascending order.

**Example 2**

Arrange +2, -5, +5, -6, +8, 0 in ascending order.

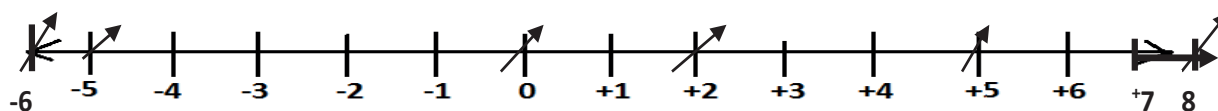

List from left to right -6, -5, 0, +2, +5, +8.  
 Be careful not to miss any number.

**Example 3**

Compare +8 and -10  
 +8 is on the right of -10  
 So +10 > -8

**Example 4**

Use <, > or = to compare  
 -15 < +10  
 -15 is on the left of +10  
 Therefore -15 is less than +10.

**Exercise**

- Arrange these from the lowest to the greatest
  - 4, +3, -10, 2
  - +7, -5, -3, 0, +5

2. Arrange these integers in descending order.
  - a)  $+7, +6, -8, -3$       b)  $-1, 0, -4, +4, +7$
3. Which is greater  $-3$  or  $+1$ ?
4. Which is less than the other  $-9$  or  $-5$ ?
5. Arrange these integers in ascending order.
  - a)  $0, +4, +7, -3, -2$
6. Use symbols  $<$ ,  $>$  or  $=$  to compare integers correctly.
  - a)  $+4$  \_\_\_  $-10$
  - b)  $-17$  \_\_\_  $-17$
  - c)  $0$  \_\_\_  $-15$
  - d)  $-15$  \_\_\_  $+3$
  - e)  $+20$  \_\_\_  $-20$

### Lesson 3: Addition of positive and negative integers using a number line

In this lesson, you will:

- Add integers using a number line.
- Solve simple word problems involving integers.

You will need:

- An exercise book, a pencil and a pen and a ruler.

**Introduction:**

You have already learnt about forward and backward movement. In this lesson, you will add integers using a number line. Arrows moving to the left show negative integers while arrows moving to the right show positive integers.

#### Step 1

Work out  $+4 + +1$  using a number line.

- a) Draw a number line like the one below.

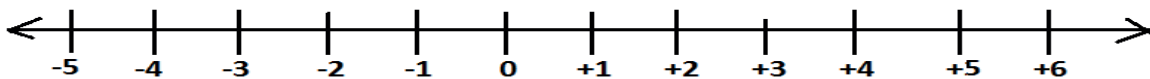

- Walk four steps ( $+4$ ) to the right of zero, then draw the arrow
- Continue from  $+4$  and move 1 step forward.

- Count all the steps from 0 to where you stopped in the second movement.

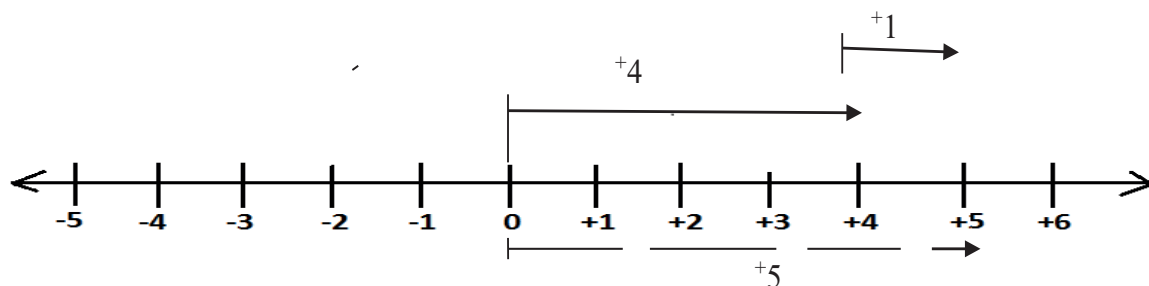

$$+4 + +1 = +5$$

You will notice that the movement from zero to where the second arrow has stopped covers +5

Therefore  $+4 + +1 = +5$

**Step 2**

Work out  $-8 + +3$

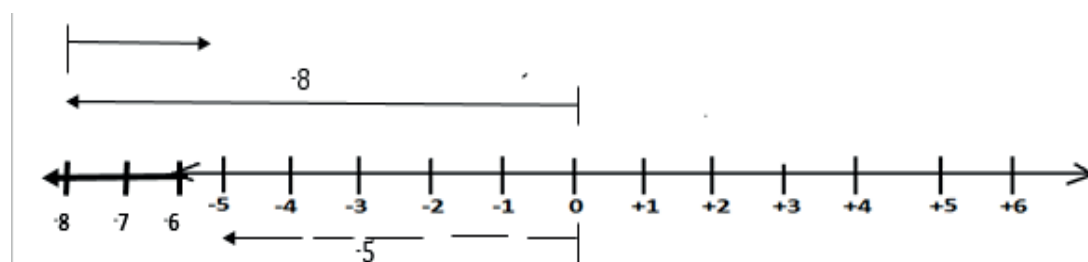

- Start from zero
- Move  $-8$  steps to the left of zero.
- Then move  $+3$  steps to the right from  $-8$

The answer is from zero to the last arrow.

Therefore  $-8 + +3 = -5$

**Exercise**

Work out using number lines.

- |              |              |
|--------------|--------------|
| 1. $+4 + +3$ | 4. $-3 + -5$ |
| 2. $-7 + +4$ | 5. $-2 + -3$ |
| 3. $+9 + -3$ | 6. $+6 + -4$ |

**Lesson 4: Adding integers without using a number line.**

**In this lesson, you will:**

- Add integers without using a number line.
- Solve word problems involving addition of integers.

**You will need:**

- Counters, a pen, a pencil, a ruler and an exercise book.

**Introduction:**

In the previous lesson, you learnt about adding positive and negative integers using a number line. You noticed that all arrows to the right of zero were representing positive integers and all arrows to the left of zero were representing negative integers.

In this lesson, you will add integers without a number line. Words like debt and borrow can represent a negative idea. Words like profit, gain, more can represent a positive idea.

**Step 1**

Activity

Work out  $-7 + +4$

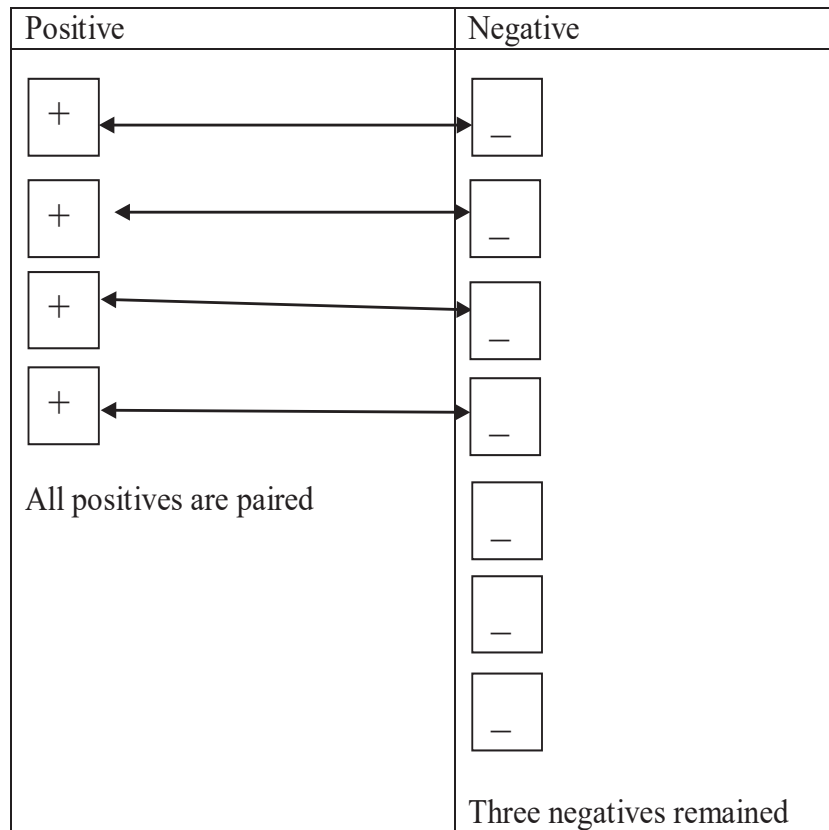

You will notice that after pairing, three negatives remained ( $-3$ ), therefore  $-7 + +4 = -3$ .

**Step 2**

**Example 1.**

Work out  $+6 + -2$

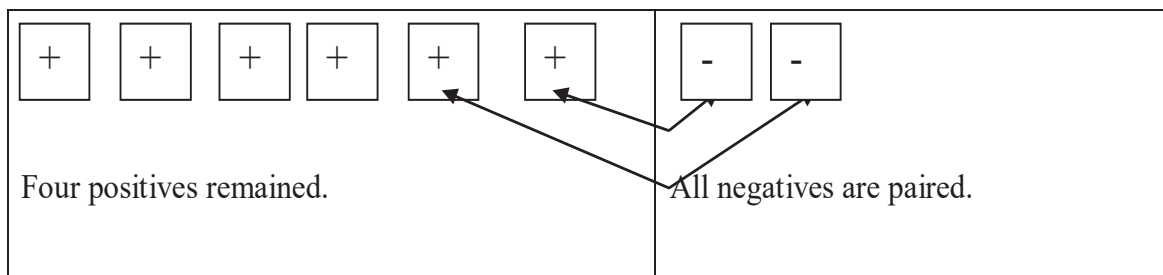

Therefore  $+6 + -2 = +4$

**Example 2**

Shanita had 10 books and gave 6 books to a friend. How many books did Shanita remain with?  
 10 books represent  $+10$  (because she had them)  
 6 books represent  $-6$  (she gave them to a friend)  
 Therefore she remained with 4 books.  
 $+10 + -6 = +4$  or  $+10 - 6 = +4$

**Example 3**

A boy borrowed sh.2,000. His mother gave him sh.5,000. If the boy paid the money how much did he remain with?  
 Sh.2,000 represent  $-2000$   
 Sh.5,000 represent  $+5000$   
 Therefore,  $-2000 + 5000$  is the same as  $sh.5000 - sh.2000 = sh.3000$ .

**Exercise**

Work out.

1.  $+7 + -3$
2.  $+5 + -4$
3.  $-10 + +3$
4.  $-9 + +7$
5. Joshua had 4 books and gave away 4 books. How many books did he remain with?
6. In a basket there were 8 rotten mangoes. If there were 14 mangoes altogether, how many good mangoes were there?
7. Martha had 9 pens. She was given another 12 pens. How many pens did she have altogether?

**Lesson 5: Subtracting integers using a number line.**

**In this lesson, you will:**

- Subtract integers using a number line

**You will need:**

- An exercise book and a pen, a ruler and a pencil.

**Introduction:**

You were introduced to adding integers using a number line. The idea of forward and backward movement will still help you to work out subtracting integers.

**Note:**

- When subtracting integers, both arrows start from zero
- The gap between the arrow heads represents the answer
- The gap should begin from the second to the first arrow head.



**Step 1: Activity**

Work out  $+4 - +6$  using a number line.

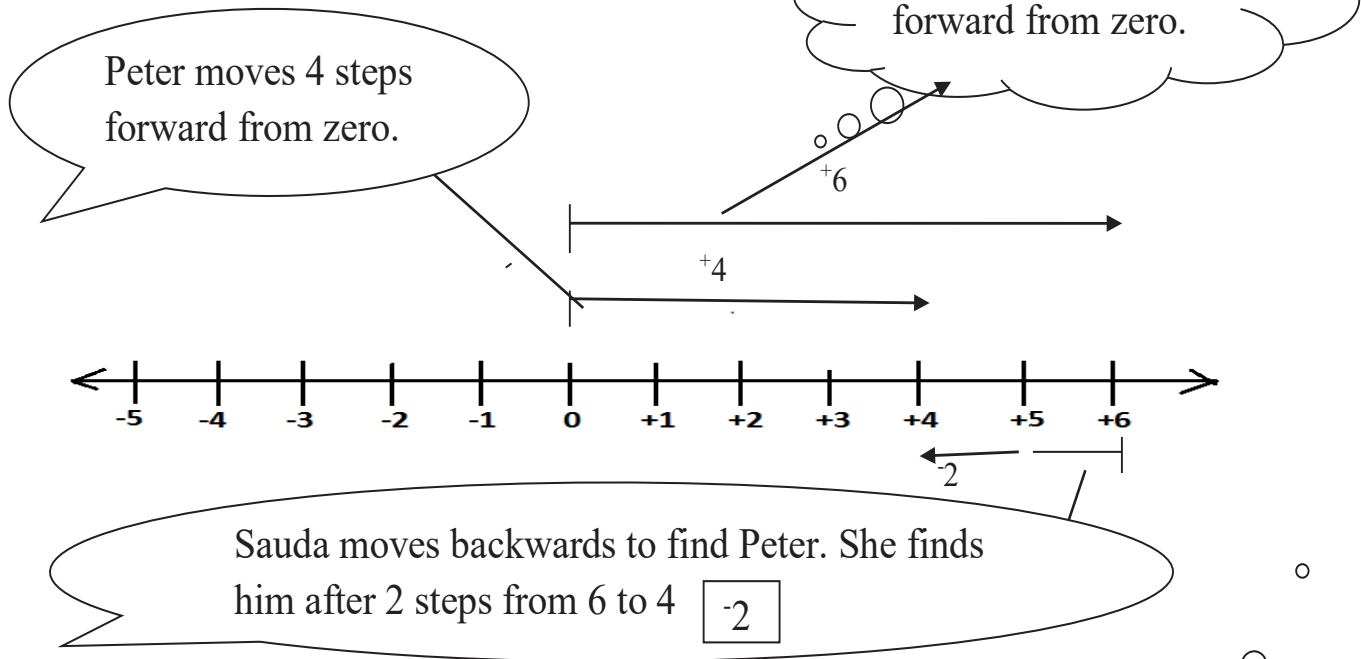

Therefore  $+4 - +6 = -2$

**Step 2**

**Example 1**

Workout  $-2 - +7$  using a number line. This time it is you and another person at your home.

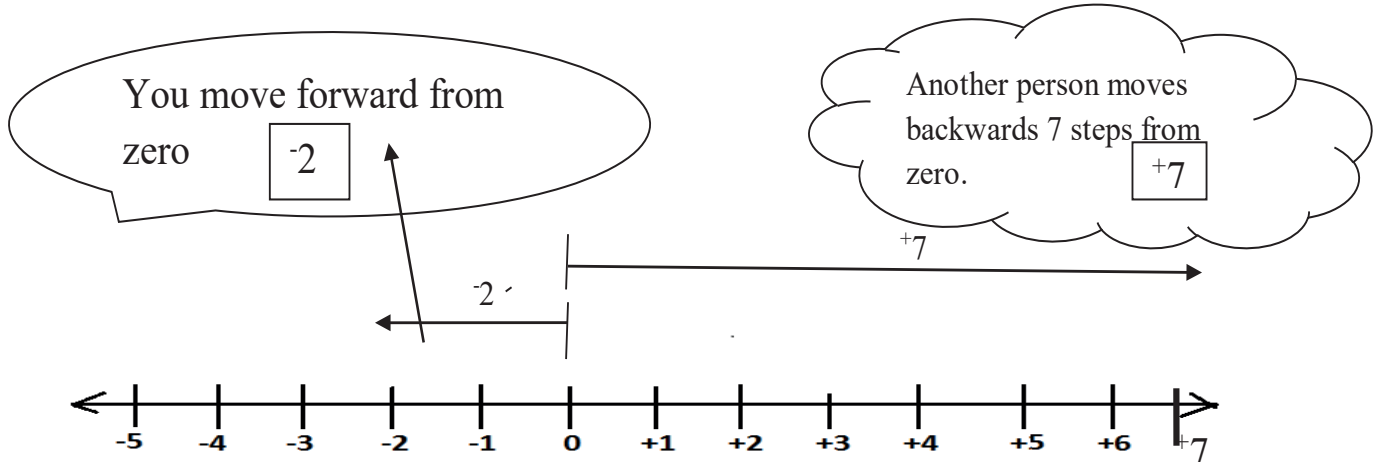

Therefore  $-2 - +7 = 9$

**Exercise**

Work out the following using number lines.

- |              |              |
|--------------|--------------|
| 1. $+2 - +4$ | 4. $-6 - +2$ |
| 2. $+5 - +3$ | 5. $-3 - +3$ |
| 3. $+4 - -3$ | 6. $-4 - -2$ |

## Lesson 6: Subtracting integers without using a number line.

### In this lesson, you will:

- Subtract integers without using a number line
- Solve word problems involving subtraction of integers.

### You will need:

- Counters, an exercise, a pen, a pencil and a ruler.

### Introduction:

You were introduced to subtracting integers using a number line. In this lesson, you are going to subtract integers without a number line and solve word problems involving addition.

The words we saw in the previous lessons like, borrow, lend, debt, gain, profit, loss are going to help us work out these problems.

### Step 1

#### Example 1

Workout  $-4 - 7$

This means you have a debt of 4 and another debt of 7

Therefore  $-4 - 7 = -11$

### Step 2

#### Example 2

If a friend is demanding you 5 books and you have 7 books. How many books do you remain with?

7 books represent  $+7$

5 books represent  $-5$

Therefore  $(+7) - (+5)$

$(+7) - (+5) = +2$

Therefore you remain with 2 books.

### Exercise

Work out the following without using number lines.

1.  $-3 - +7$

3.  $-5 - 6$

2.  $-4 - -4$

4.  $-4 - 7$

5. A man has a debt of sh.1,000. If he has sh.5000, how much money will he remain with?

6. Brenda was given 40 apples and she gave away 25 to her friends. How many apples did she remain with?

7. Subtract  $+3$  from  $+6$ .

8. Robert had sh.3,000 and gave out sh.1,800. How much money did she remain with?

## TOPIC: ALGEBRA

### Lesson 1: Algebraic expressions

#### In this lesson, you will:

- Read sentences that require algebraic expressions.
- Write algebraic expressions for **the** given sentences.

#### You will need:

- An exercise book and a pen.

#### Introduction:

Writing algebraic expressions is like writing a sentence in your language. It helps us to think creatively and critically.

It also helps us to break down a problem and find its solution, for example, when we use words like **more than, less than, twice, three times, older, younger** in our conversations.

Such words are algebraic expressions and you are going to use them along with the four major operations, +, -,  $\times$  and  $\div$ .

#### Step 1

##### Activity

##### Try these by writing an expression for each

- Cate has 8 hens. Sarah has 2 more hens than cate.  
Then sarah has  $(8 + 2)$
- 4 more than  $p = p + 4$
- 3 subtracted from  $x = x - 3$
- Twice  $x = 2x$

#### Step 2

##### Now you can study these examples.

1. Musa is 4 years older than Arthur, who is  $p$  years old.  
How old is Musa?  
 $(p + 4)$  years.
2. Multiply  $p$  by 7  
 $= p \times 7$   
 $= 7p$
3. When  $k$  is added to 9 the answer is 12.  
 $9 + k = 12.$

Remember all the algebraic expressions involve all the major mathematics operations +, -,  $\times$ ,  $\div$

#### Exercise

1. Subtract 5 from  $k$
2. John is 6 years older than Ann, who is  $X$  years old.

3. The sum of p and 4 is 11
4. 7 divided by k.
5. q divided by 10.

**Lesson 2: Like terms.**

**In this lesson, you will:**

- Collect like terms.
- Simplify expressions.

**You will need:**

- Books, sticks ,pens and an exercise book.

**Introduction:**

Collecting like terms helps us to be organized in life, for example, at home we learn to put same things together, that is, cups separate from plates and clothes separate from shoes. In this lesson, you will collect terms that are the same. These are called like terms.

**Step 1**

**Activity**

- Make a group of 3 onions, 4 sticks, 2 onions and 5 sticks.  
Write the expression  
3 onions + 4 sticks + 2 onions + 5 sticks
- Now put similar things together.  
3 onions + 2 onions + 4 sticks + 5 sticks.  
5 onions + 9 sticks.

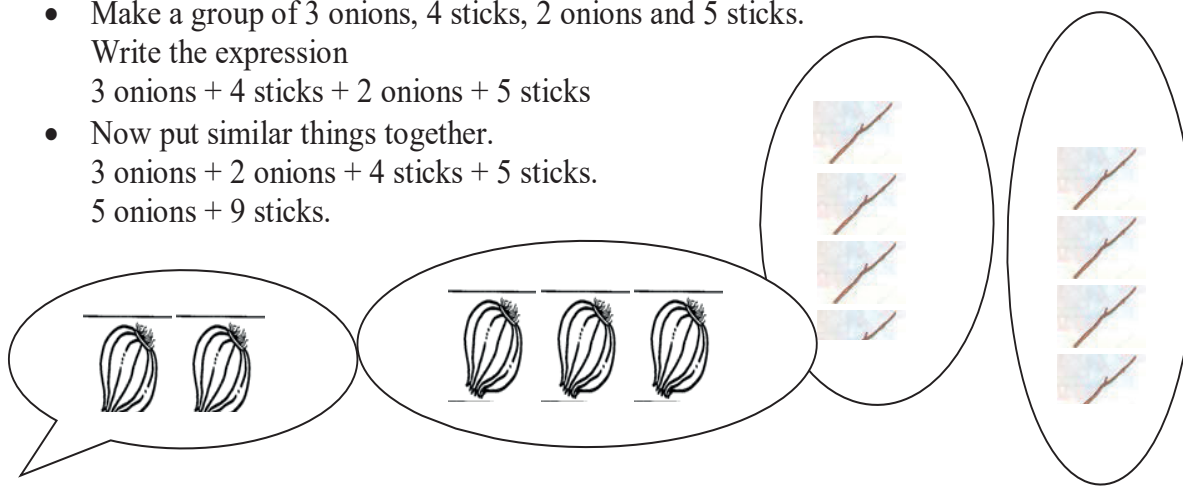

**Step 2**

**Study these examples.**

**Example 1**

Juma has 13 cows; he has 3 goats and bought another 5 cows.

How many animals does he have altogether

$$\begin{aligned}
 &13 \text{ cows} + 3 \text{ goats} + 5 \text{ cows} \\
 &13\text{cows} + 5\text{cows} + 3 \text{ goats} \\
 &= 18 \text{ cows} + 3 \text{ goats.}
 \end{aligned}$$

**Example 2**Simplify:  $3b + 2p + 4b + 6p$ .

$$3b + 4b + 2p + 6p$$

$$\underline{7b + 8p}$$

Collect like terms.

Simplify

**Exercise**

Collect like terms and simplify

- |  |                                 |
|--|---------------------------------|
| 1. 4 bottles + 2 shirts + 2 bottles + 3 shirts | 6. 20 sheep + 5 ducks – 2 sheep |
| 2. 10 hens + 5 ducks – 3 hens                  | 7. $1a + 2s + 1a$               |
| 3. 9 cups + 7 hats + 2 cups + 4 hats           | 8. $2k + 7k - 3k$               |
| 4. 1 pot + 3 clocks + 1 pot                    | 9. $3p + 15b - 1p$              |
| 5. 4 books + 2 cups + 3 books + 2 cups         | 10. $17c - 5c + 6s + 2s$        |

**Lesson 3: Solving equations by subtracting****In this lesson, you will:**

- Solve simple equations by subtracting from both sides.
- Solve word problems involving equations by subtracting from both sides.

**You will need:**

- A pencil, sticks, strings, a paper, a pen and an exercise book.

**Introduction:**

An equation has two sides, the left hand side and the right hand side.

Solving equations helps us to know that some things are equal to others in our everyday life, for example, two notes of 5000 shillings equals' sh.10,000. That is already an equation. In this lesson, you will balance the equation by subtracting from both sides.

When the two sides balance, then you have solved the equation.

**Step 1****Activity**

- Make a simple weighing scale using sticks, strings and hard paper.
- Weigh soil and stones on the scale.
- Keep adding and subtracting until the two sides balance.

## Step 2

Now study these examples.

### Example 1

Solve :  $r + 3 = 10$

$$r + 3 - 3 = 10 - 3$$

$$r = 7$$

Subtract 3 from both sides

### Example 2

Solve  $11 + w = 14$

$$11 - 11 + w = 14 - 11$$

$$w = 3$$

Subtract 11 from both sides.

### Example 3

When 5 is added to a number, the answer is 7. What is the number?

Let the number be  $k$

$$k + 5 = 7$$

$$k + 5 - 5 = 7 - 5$$

$$k = 2$$

### Exercise

Solve the equations below.

1.  $x + 2 = 5$

3.  $p + 15 = 13$

2.  $r + 7 = 13$

4.  $m + 14 = 30$

5. When 17 is added to  $y$  the answer is 20. Find the value of  $y$

6. What number do you add to 11 to get 15?

7. The sum of  $w$  and 10 is 21. What is  $w$ ?

8. If I add 6 to  $a$ , I get 18. Find the value of  $a$ .

## Lesson 4: Solving equations by adding to both sides.

In this lesson, you will:

- Solve equations by adding to both sides.
- Solve word problems involving equations by adding to both sides.

You will need:

- Counters, an exercise book and a pen.

### Introduction:

In the previous lesson, you **learnt how** to solve equations. You will also solve word problems that involve equations. You need to read the word problem, interpret it and form an equation then solve it. As you noticed in the previous lesson, in order to solve an equation, the two sides must balance.

In this lesson, we are going to balance the equation.

**Step 1****Activity**

- Get a family member.
- Put a number of counters in your hand. Give some to your family member.
- Now count the remaining counters and let the family member count his or hers.
- Assuming you gave away 12, and 18 remained. How many counters did he have?

An equation can be  $k - 12 = 18$

$$K - 12 + 12 = 18 + 12$$

$$k = 30.$$

**Step 2**

Study the examples below.

**Example 1**

Solve form:  $m - 17 = 14$   
 $m - 17 + 17 = 14 + 17$   
 $m = 31$

Add 17 to both sides.

**Example 2**

When Kirunda ate 9 oranges, he remained with 3 oranges. How many oranges did he have at first?

If he had  $k$  oranges.

$$k - 9 = 3$$

$$k - 9 + 9 = 3 + 9$$

$$k = 12$$

add 9 to both sides.

**Exercise :**

- 1) Solve the equations below:
  - a)  $p - 2 = 5$
  - b)  $r - 7 = 10$
  - c)  $k - 4 = 8$
  - d)  $f - 20 = 16.$
  - e)  $x - 3 = 15$
  - f)  $y - 5 = 7$
- 2) When 7 is subtracted from a number, the answer is 13. What is the number?
- 3) I think of a number, take away 4, the answer is 9. Find the number.
- 4) A girl removed 15 mangoes from a basket and 12 remained. How many mangoes were in the basket altogether?

**Lesson 5: Solving equations by dividing**

In this lesson, you will:

- Solve simple equations by dividing.
- Solve word problems involving equations by dividing.

You will need:

- Tins, counters and an exercise book.

**Introduction:**

As you earlier learnt, solving an equation means balancing both sides.

When solving an equation, it is possible to balance both sides by dividing both sides by the same number.

In this case, you must have good knowledge about multiplication tables.

In this lesson, you are going to solve equations which involve dividing both sides of the equation.

**Step 1**

**Activity**

- Get two containers and 12 counters. Put the counters, one at a time, in each container.
- How many counters will you put in each container?
- This can be found quickly by dividing 12 by 2.
- What answer have you got?

A picture of two baskets.

A picture of 12 bottle tops.

**Step 2**

Study the examples below.

**Example 1**

Solve for q:  $3q = 15$

$$\begin{array}{r} 1 \cancel{3}q \cancel{=} \cancel{15} \cancel{5} \\ 1 \cancel{3} / \cancel{3} \cancel{5} \\ q = 5 \end{array}$$

Divide both sides by 3

**Example 2**

The product of 2 numbers is 24. The first number is 8. Find the second number.

Let the second number be h.

Multiply 8 by h

$$8 \times h = 24$$

$$\begin{array}{r} \cancel{8}h = \cancel{24} \cancel{3} \\ \cancel{8} \quad \cancel{8} \end{array}$$

$$h = 3$$

Divide both sides by 8



**Example 3**

Kenneth is  $q$  years old and Hadija is twice as old as Kenneth. If their total age is 30 years, find Kenneth's age.

Kenneth is  $q$   
 Hadija is  $2q$   
 But  $q + 2q = 30$   
 $3q = 30$   
 $\frac{1}{3} \frac{3q}{3} = \frac{30}{3} \frac{1}{1}$   
 $q = 10$   
 Kenneth is 10 years.

Divide both sides by 3  
 Twice as old  
 Form an equation.

**Example 4**

The perimeter of a square garden is 36m. One side is  $k$ . Find  $k$ .

$4 \times \text{side} = \text{Perimeter}$   
 $4 \times k = 36\text{m}$   
 $4k = 36\text{m}$   
 $\frac{4k}{4} = \frac{36\text{m}}{4} \frac{1}{1}$   
 $k = 9\text{m}$

Divide both sides by 4  
 Multiply  $k$  by 4 because the four sides are equal

**Exercise**

- Solve the equations below
  - $2x = 14$
  - $4k = 28$
  - $5m = 50$
  - $7y = 35$
- What number when multiplied by 9 gives 54?
- The area of a rectangle is  $40\text{cm}^2$ . Its length is 8cm. find its width.
- The perimeter of a square is 24cm. Find its side in centimetres.
- Chemtai is  $m$  years old and Ngobi is twice as old as Chemtai. If their total age is 36years, how old is each of them?
- The area of a rectangle is  $24\text{cm}^2$ . Its length is 8cm. Find its width?







National Curriculum  
Development Centre,  
P.O. Box 7002,  
Kampala.

---

[www.ncdc.go.ug](http://www.ncdc.go.ug)