

# KING FAHAD ISLAMIC PRI. SCH.



## 2021 COVID-19 REVISION WORK - 06

**CLASS : P.4**  
**SUBJECT : ENGLISH LANGUAGE**

Name: \_\_\_\_\_ Stream \_\_\_\_\_

### Use the correct form of the word in brackets to complete each sentence.

1. You will not get good results if you write the work \_\_\_\_\_.  
(careless)
2. Five \_\_\_\_\_ were kidnapped in Akokoro sub county last year. (child)
3. Those books are not yours, they are \_\_\_\_\_.(me)
4. Hanifa fell down while she was \_\_\_\_\_ to the dining hall. (run)
5. Sara \_\_\_\_\_ the teacher's table yesterday. (break)

### Rearrange the words to make a correct sentence.

6. cleaning room Dora her is.  
\_\_\_\_\_

7. making noise Who was?  
\_\_\_\_\_

### Rewrite these sentences as instructed in the brackets.

8. Karim is a clever boy. Khalil is a clever boy.

(Use: .....and .....)

\_\_\_\_\_

\_\_\_\_\_

9. Here is the lady. She sells good oranges.

(Join using .....who.....)

---

---

10. I wanted to buy vegetables. I went to the market.  
(Use: .....because.....)

---

---

11. Kasim was reading a book. He heard a child crying.  
(Begin: As.....)

---

---

12. Kato is hardworking. Babirye is hardworking.  
(Begin: Both .....)

---

---

13. They don't have any money. (Use.....some.....)

---

---

14. I fell down. I did not cry.  
(use.....but.....)

---

---

15. Jamil prefers reading to playing. (Use: .....likes.....)

---

---

16. Habib has a book. Bassam has a pencil. (Use.....and.....)

---

---

17. That is the chair. It got broken last week.

(Join: Using .....which.....)

---

---

18. My name is Samil. (form a suitable question)

---

---

19. Kalonde bought a book a pencil a ruler and a rubber (punctuate the the sentence correctly)

---

---

20. This is my book. (Begin: These.....)

---

---

21. All cows have heads. (Begin: Every.....)

---

---

22. A hoe is useful. A watering can is useful.  
(Use: .....as .....as.....)

---

---

23. Halima is smart. Taslim is very smart. (Use: .....than.....)

---

---

24. That is the place. I saw a mad man there.  
(Join using: ..... where.....)

---

---

25. This bag belongs to me. (End .....mine.)

---

26. Buraida was very young. He couldn't go to school.  
(Use.....too.....to.....)

---

---

27. Here is the man. His cows were stolen. (Use.....whose.....)

---

---

28. Rearrange the sentences to make a correct story.

A

1. She then gives us work to do in our books.
2. We begin lessons with prayers.
3. In our new class.
4. She marks all our books.
5. Then the teacher begins teaching us.

1. \_\_\_\_\_

2. \_\_\_\_\_

3. \_\_\_\_\_

4. \_\_\_\_\_

5. \_\_\_\_\_



B

1. She served it to her children to eat.
2. Mother went to the market to buy some bananas.
3. She wrapped them in banana leaves.
4. She peeled the bananas.

5. Then she put them on the fire to cook.

1. \_\_\_\_\_
2. \_\_\_\_\_
3. \_\_\_\_\_
4. \_\_\_\_\_
5. \_\_\_\_\_

29. On Saturday, 9<sup>th</sup> March 2020, Janat was going to see her aunt.  
Her aunt lives in Kyengera. Study the pictures carefully and then  
answer the questions.

		
Janat was going to see her aunt. She got on the bus at 10.00 a.m.	She found a free seat at the back of the bus. There was a blue handbag on the seat.	She opened the handbag and found ten thousand shillings and an envelope.

### Questions

1. Where was Janat going?

---

---

2. In which month did Janat visit her aunt?

---

---

3. At what time did Janat get on the bus?

---

---

4. Where did Janat find a free seat in the bus?

---

---

5. What did Janat find on the seat?

---

---

6. How much money was in the bag?

---

---

7. When did Janat visit her aunt?

---

---

8. Name one thing Janat found in the bag.

---

---

9. On which day of the week did Janat visit her aunt?

---

---

10. Write 9<sup>th</sup> in words.

---

---

30. Read the story below and answer the questions in full sentences.

**A GAME WARDEN**

My father is Otim Jamil. He is a game warden in Bero National Game Park. A game warden is a person who protects wild animals from the hunters and takes care of them. People who kill wild animals in game

parks are called poachers. He says that it is hard to work in game parks because he sometimes fears that animals might kill him when he is moving around the game park.

He meets different animals like the giraffe which is the tallest, the elephant which is the biggest and the lion which is the king of the jungle. He likes his job because he enjoys looking at different animals. The wild animals can be found in game parks, game reserves and zoos. They are important because the country gets a lot of money from the tourists who come to see them.

**Questions**

**(a) What is the story about?**

---

---

**(b) Where does Otim Jamil work?**

---

**(c) Which is the biggest animal?**

---

---

**(d) Who are poachers according to the story?**

---

---

**(e) Why does Otim Jamil like his job?**

---

---

**(f) Write the title of the story.**

---

Name any two places where wild animals can be found.

(g) \_\_\_\_\_

(h) \_\_\_\_\_

Write the opposites of:

(i) biggest \_\_\_\_\_

(j) king \_\_\_\_\_

KING FAHAD



# KING FAHAD ISLAMIC PRI. SCH.



## 2021 COVID-19 REVISION WORK 07

**CLASS : P.4**

**SUBJECT : ENGLISH LANGUAGE**

Name: \_\_\_\_\_ Stream \_\_\_\_\_

### Use the words in the brackets to complete the sentences.

- 1) Our \_\_\_\_\_ is a kind lady. (teach)
- 2) Tam-tam \_\_\_\_\_ to school every day. (walk)
- 3) Give me that book because it is \_\_\_\_\_. (me)
- 4) Of the two girls, Hamida writes \_\_\_\_\_ than Janat. (good)
- 5) We eat beef \_\_\_\_\_ a week. (one)

### Fill in the gap with a correct word or group of words.

- 6) Do not play with fire, \_\_\_\_\_ it will burn you.
- 7) Most children come to school \_\_\_\_\_ foot.
- 8) There isn't \_\_\_\_\_ food on the plate.
- 9) The \_\_\_\_\_ looks after our sick teeth.
- 10) January is the \_\_\_\_\_ month of the year.

### In questions 11 and 12, arrange the words in alphabetical order.

11) beautiful, brown, bad, black.

---

12) dried, planted, harvested, stored.

---

### Give the opposites of the following words.

13) Lena is a hardworking boy,

---

14) We should walk quickly to our school.

---

Re-write the sentences giving the plural of the underlined words.

15) Thakib has a calf on his farm.

---

16) The teacher is not coming today.

---

Arrange the words to form a correct sentence.

17) fastest is Andrew boy in our the class.

---

18) you going are home ?

---

19) new has Nekesa dress a.

---

Write a sentence using each of these words.

23) had \_\_\_\_\_

24) hard \_\_\_\_\_

Give one word to the underlined group of words.

25) Faris went to see the man who makes furniture.

---

26) Jakim does not eat meat of a pig.

---

27) The place where books are kept at school is closed.

---

28) Read the letter below and answer the questions in full sentences.

MUKONO Junior School,

P.O. BOX 150,

MUKONO.

3<sup>th</sup> July, 2021.

Dear Jamilah,

I hope you are fine and doing well at your school, King Fahad.

I Keep thinking and praying to God for you to recover from malaria which has disturbed your for a week. My parents sent me a message that they would visit you one Saturday since you are in boarding section. I told them to bring for you a lot of juice to gain strength.

I wish you a quick recovery. Send greetings to your friend . Halima and the teacher of English, Jalia.

From your friend,

Leila.

Questions.

1) Who wrote the letter?

---

2) In which school is the writer?

---

3) In which school is Jamilah?

---

4) To whom was the letter written?

---

5) What was Ann suffering from?

---

---

6) For how long had Ann suffered ?

---

7) Who is Halimah

---

8) What subject does Jalia teach ?

---

9) Why do you think Jamilah needed juice ?

---

10) To whom is Leila praying ?

---

29) Read the notice below and answer the questions about it in full sentences.

**Birthday : Party ! Birthday Party !**

**Place : Wonder World**

**Date : Saturday, 3<sup>th</sup> July, 2021**

**Time : 9.00am- 4.00 p.m**

**Fee : Free of charge.**

**Guest of honour : Uncle Farid.**

**Other guests : Relatives and well wishers.**

**By Laila, the birthday girl.**

**Questions.**

1) What is the notice about ?

---

2) What is the venue for the birthday party?

---

3) When will the birthday party take place ?

---

4) Who is the chief guest ?

---

5) At what time will the birthday party start ?

\_\_\_\_\_

6) Who wrote the notice ?

\_\_\_\_\_

7) At what time will it end ?

\_\_\_\_\_

8) Who have been invited ?

\_\_\_\_\_

9) In which month will the party take place ?

\_\_\_\_\_

10) Write in full : p.m.

\_\_\_\_\_

**30) Read the story and use the words in the box to make it complete.**

own	hungry	panga	evening	greeting
villages	season	because	land	man

Once there was a \_\_\_\_\_ who did not want to work. In the morning, he walked around the village \_\_\_\_\_ people who worked in their gardens. Every day, he would tell them not to work very hard \_\_\_\_\_ they would grow old quickly.

During the harvesting \_\_\_\_\_, he would ask people for food. Everybody gave him food. He sold some and used the money for drink beer. People were not happy with this lazy man. One day, the \_\_\_\_\_ met and agreed not to give him any more food.

“He does not want to work,” one woman said. “We should tell him and his family to grow their own food,” said another.

One morning, he went begging for food and nobody gave him.

In the \_\_\_\_\_, he had not got food. He was very \_\_\_\_\_ and sad.

“Tomorrow, “ he said to his wife, “ I shall ask my friend for a piece of land so that I can grow my \_\_\_\_\_ crops like other people in the village.

His friend gave him, a piece of \_\_\_\_\_ near a forest. He also gave him three hoes, one slasher, a \_\_\_\_\_ and maize.

KING FAHAD

# KING FAHAD ISLAMIC PRI. SCH.



## 2021 COVID-19 REVISION WORK - 06

**CLASS : P.4**

**SUBJECT : MATHEMATICS**

**NAME:** \_\_\_\_\_ **STREAM:** \_\_\_\_\_

1. If set  $V = \{ 1, 2, 3, 4, 5 \}$ , find  $n(V)$ .
2. How many edges does a cuboid have?
3. In the space below draw a cone.
4. A boy moved a distance of 90m. How long is this distance in cm?
5. Express  $2\frac{1}{5}$  as an improper fraction.
6. Which number comes before 19?
7. The cost of buying a hand bag is shs.2500. How much money will one need to buy three similar hand bags?
8. Work out the perimeter of the figure below.

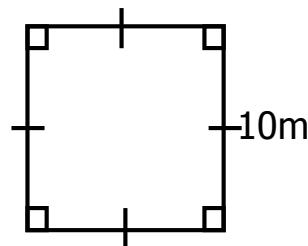

9. How many days are there in 4 weeks?

10. Mariam has a mass of 25kg and Ann has a mass of 35kg. Write the names of the children on the diagram below.

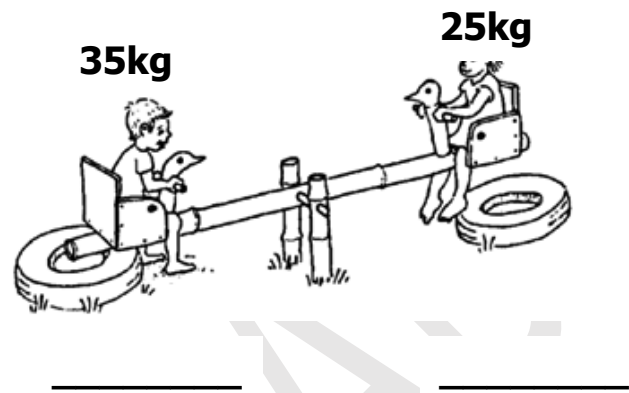

11. Write the place value of 8 in the number 10059.

12. On a farm, there are 7451 goats and 128 cows. How many animals are on the farm altogether?

13. Change 9 metres to cm.  
(1 metre = 100cm)

14. In the space below, use a sharp pencil and a ruler to draw a rectangle.



15. Given that set  $M = \{2, 3, 5, 6\}$  and Set  $N = \{1, 2, 5, 7, 8\}$ .

(a) Represent the above information on a Venn diagram below. (3 marks)

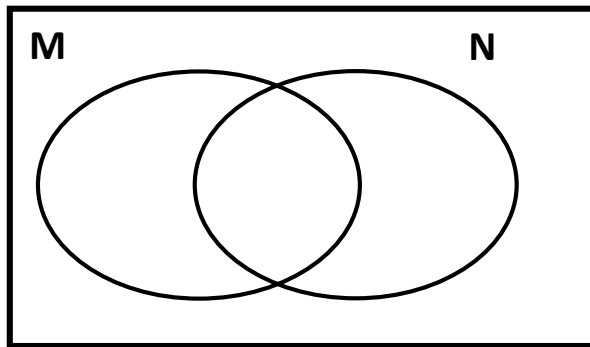

(b) Find:

(i)  $(M \cup N)$  (1 mark)

(ii)  $n(M \cap N)$  (2 marks)

16. (a) What number is shown on the abacus? (1 mark)

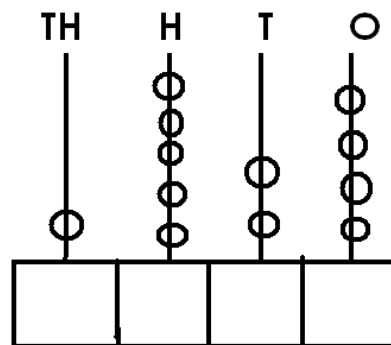

(b) Write "four thousand sixty – nine in figures. (2 marks)

(c) Express 26 in Roman numerals. (2 marks)

4

17. (a) Name the shapes below. (3 marks)

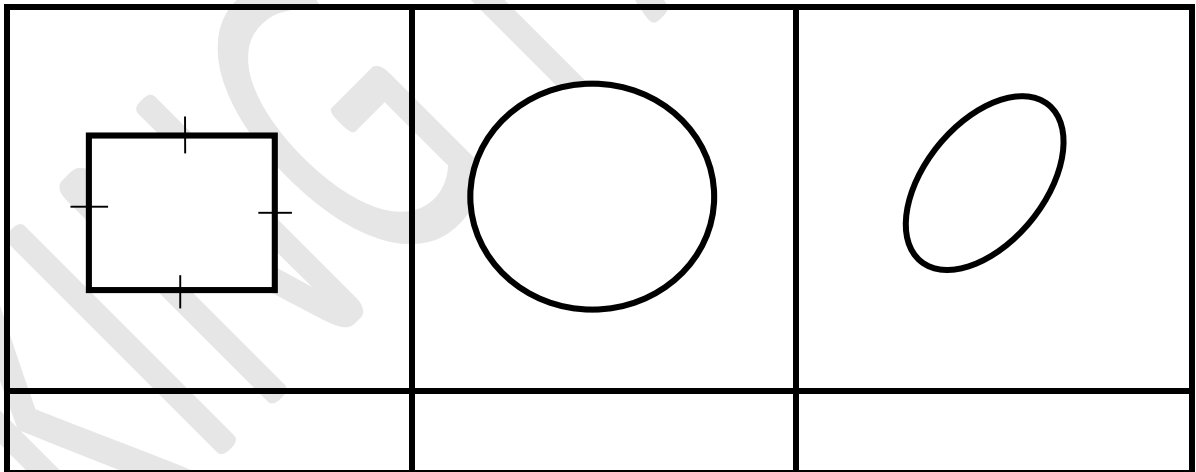

(b) Workout the area of the figure below. (2 marks)

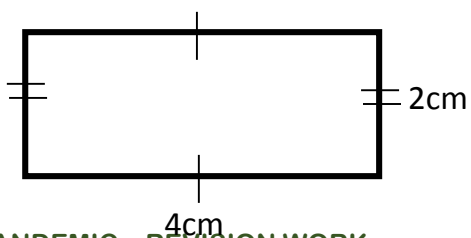

18. Workout:

(a)  $\square + 5 = 9$  (2 marks)

(b)  $\square \times 4 = 16$  (2 marks)

(b)  $\square - 9 = 1$  (2 marks)

19. The table below shows a price list at a certain shopping mall.

Item	Price
1kg of meat	Sh.8,000
1kg of sugar	Sh.2,400
1kg of rice	Sh.2,600
1 black book	Sh.2,500

(a) How much money will Robert pay for 2kg of rice? (2 marks)

(b) If Ali bought 2 black books and 2kg of sugar, how much did he pay?  
(2 marks)

(c) Find the total cost of all items on the list. (2 marks)

20. Use =, < or > to complete the following.

(a)  $95 + 5$  \_\_\_\_\_  $5 + 50$

(b)  $46$  \_\_\_\_\_  $64$

(c)  $24 \div 3$  \_\_\_\_\_  $2 \times 4$

(d)  $89 - 42$  \_\_\_\_\_  $2 \times 20$

(e)  $XI$  \_\_\_\_\_  $XIX$

(5 marks)

# KING FAHAD ISLAMIC PRI. SCH.



## 2021 COVID-19 REVISION WORK - 07

**CLASS : P.4**  
**SUBJECT : MATHEMATICS**

**NAME:** \_\_\_\_\_ **STREAM:** \_\_\_\_\_

1. Add: 
$$\begin{array}{r} 32 \\ +14 \\ \hline \\ \hline \end{array}$$

2. Find the next number in the sequence.

5, 10, 15, 20, \_\_\_\_\_

3. Name the shaded fraction.



4. Fill in correctly.

633 \_\_\_ hundreds \_\_\_ tens \_\_\_ ones.

5. Given that set  $K = \{ 2, 4, 6, 8, 7 \}$

How many members are in set K?

6. If  = 3 trees, how many trees are represented by



7. Find the missing number.

$$\square + 3 = 7$$

8. One book costs shs. 300. Find the cost of 3 similar books?

9. Name the shape below.

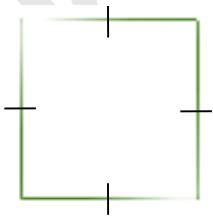

10. Subtract: 346

$$\begin{array}{r} 346 \\ -213 \\ \hline \\ \hline \end{array}$$

11. What is the place value of 4 in the number 3491?

12. Add:  $\frac{1}{5} + \frac{2}{5} =$

13. Tell the time shown on the clock face.



14. Share 16 oranges equally among 4 girls. How many will each get?

15. Below is a shopping list of items in Mr. Mukasa's shop.

A book shs. 500

A pencil shs. 200

A rubber shs. 150

A ruler shs. 400

a) Find the cost of a ruler and a pencil altogether. (2 marks)

b) Which is the most expensive item in Mr. Mukasa's shop. (1 mark)

c) Find the total cost of all the items in Mr. Mukasa's shop. (2 marks)

16. Fill in the missing numbers below.

(1 mark @)

a) 2, 4, 6, 8, \_\_\_\_\_



b) 1, 3, 5, 7, 9, \_\_\_\_\_

c) Find the place value of each digit in the number. (3 marks)

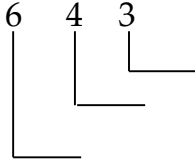

17. Salam scored the following marks in midterm examinations.

Subject	Science	English	MTC	SST
Marks	80	95	98	88

a) In which subject did he score the highest marks? (1 mark)

b) What was James's score in Science? (1 mark)

c) Find the total marks in the four subjects. (2 marks)

18. Find the missing numbers. (2 marks @)

i)  $x + 5 = 10$

ii)  $\square - 3 = 10$

iii)  $8 \div \square = 4$

19. Halima is 12 years old and Ali is 9 years old.

a) Who is older? (1 mark)

b) Who is younger? (1 mark)

c) Find their total age. (2 marks)

20. The table below shows the attendance for King Fahad Islamic Primary School on a certain day. **(2 marks @)**

Class	P.1	P.2	P.3	P.4	P.5	P.6	P.7
Number of pupils	40	25	30	35	20	25	30

- a) Which class had the highest attendance?
- b) What is the difference between the highest attendance and the lowest attendance?
- c) What is the sum of pupils in P.2 and P.4?

# KING FAHAD ISLAMIC PRI. SCH.



## 2021 COVID-19 REVISION WORK - 06

**CLASS : P.4**

**SUBJECT : INTERGRATED SCIENCE**

**NAME:** \_\_\_\_\_ **STREAM:** \_\_\_\_\_

1. Identify the main natural source of light and heat on earth.

.....

2. Mention any one people made change in the environment.

.....

3. Write any one way traffic accidents can be controlled.

.....

4. Identify the sense organ which a dog uses to taste food.

.....

5. Mention one element of a good health home.

.....

6. Name the type of pollination shown below.

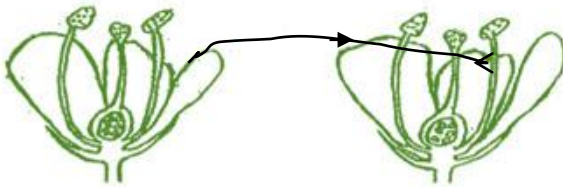

.....

7. State any one message given to children during PIASCY.

.....

8. Identify the type of soil with the soil particles marked.

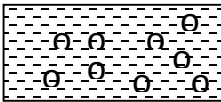

**M**

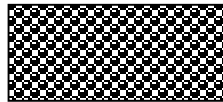

**W**

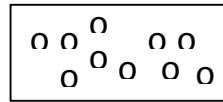

**Y**

-----  
9. Why do bees and other insects visit flowers?  
-----

10. How is photosynthesis useful to people?  
-----

11. Why are rats considered to be wild animals?  
-----

12. Mention one natural change in the environment.  
-----

13. In the space below, draw a simple leaf.

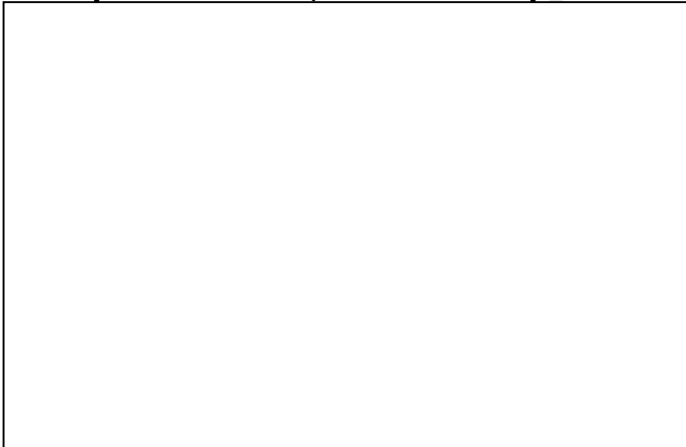

14. State the way in which a spider is different from a house fly.  
-----

15. How can crop farmers manage a dry season in their gardens?  
-----

16. Identify any one person found in a new nuclear family.  
-----

17. Which plant process is shown below?

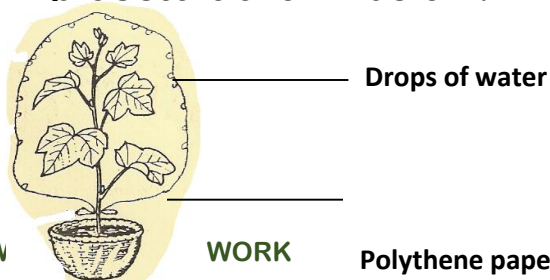

-----  
18. Name the main natural source of water in the environment.  
-----

19. Identify one way through which people get food.  
-----

20. How is a shadow formed?  
-----

21. Mention one advantage of raw planting in crop growing.  
-----

22. Name the part of a bean seed marked B in the diagram below.

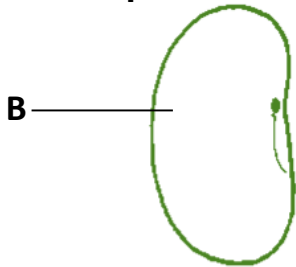

-----  
23. Name one way of preserving fish at home.  
-----

24. The diagram shows a life cycle of an insect. Use it to answer the questions that follow.

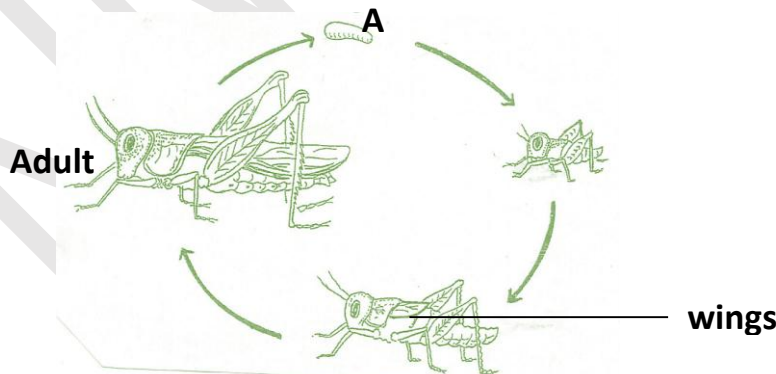

(a) Name the life stage marked A and B.

(i) A-----

(ii) B-----

(b) Apart from a grass hopper, identify any other insect with a similar life cycle.

(c) Mention any one way in which insects are useful to people.

25.(a) Air is a mixture of gases. Mention any two gases which are components of air.

(i) -----

(ii) -----

b) Identify the property of air shown below.

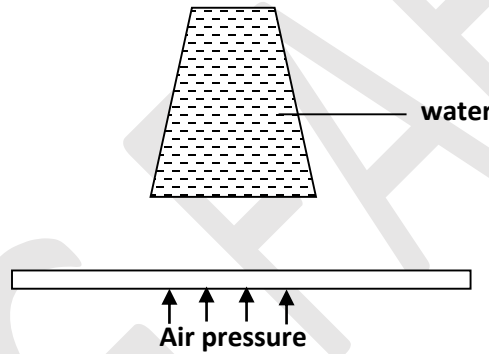

(c) Give the difference between air and wind.

26.(a) Mention two activities a primary four child can do to promote sanitation at home.

(i) -----

(ii) -----

(b) Mention one danger likely to occur in a home with poor sanitation.

(c) Apart from a broom, identify any other material to promote sanitation

at home.

27. (a) Write any one sign of a dehydrated child.

(b) Mention two causes of dehydration.

(i) -----

(ii) -----

(c) Why should dehydrated people be given (oral rehydration solution)?

28(a). The diagram below shows the vertical arrangement of soil layers.

Study it carefully and answer the questions that follow.

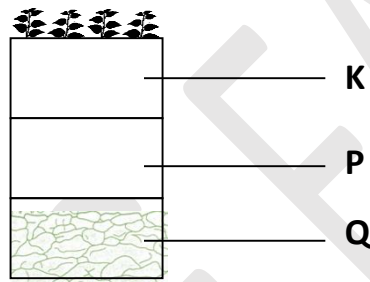

(a)(i) Name the soil layer marked P.

(ii) Mention one living organism which stays in layer K.

(b) Why is sand soil not good for crop growing?

(c) How can a farmer keep the soil fertile?

29.(a) Briefly explain the term personal hygiene.



(b) Mention two danger of poor personal hygiene to a person.

(i) .....

(ii).....

c) Draw and name one material people use to keep their bodies clean.



The diagram below shows a water cycle. Study it carefully and answer the questions that follow.

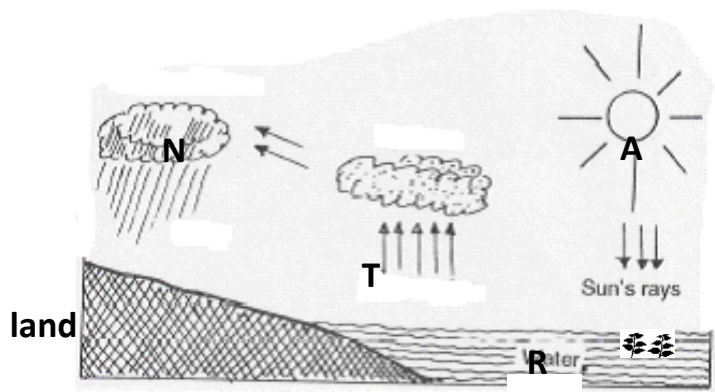

30.(a) Name the features marked R and N.

(i) R .....

(ii) N .....

(iii) R .....

(b) How is the sun useful in the formation of rain?

.....

# KING FAHAD ISLAMIC PRI. SCH.



## 2021 COVID-19 REVISION WORK 07

**CLASS : P.4**

**SUBJECT : INTERGRATED SCIENCE**

**NAME:** \_\_\_\_\_ **STREAM:** \_\_\_\_\_

1) In the space below, draw the garden tool used for watering seedlings.

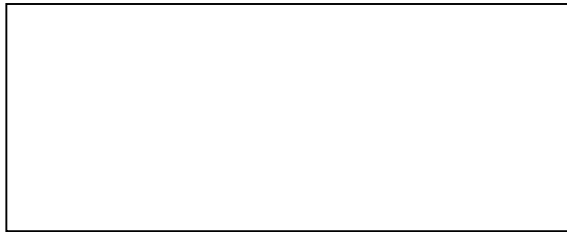

2) Why are we advised to wash our hands after picking rubbish?

\_\_\_\_\_

3) In which **one** way can mulching be dangerous to crops ?

\_\_\_\_\_

4) How is the practice of brushing teeth after every meal helpful to people ?

\_\_\_\_\_

5) Why should water for drinking be boiled?

\_\_\_\_\_

6) Mention any **one** example of a food stuff which provides energy to the body .

\_\_\_\_\_

The diagram below shows external parts of a seed.

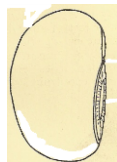

7) Use an arrow and letter “Z” to show a micropyle.

\_\_\_\_\_

8) How are roots important to a plant?

---

9) Opio lives in a home without a latrine. Identify any one disease which can break out in such a home.

---

10) Why is loam soil the best for growing crops ?

---

11) Give any one cause of soil erosion in your area.

---

12) Write any one local material used for making balls.

---

13) Which vector spreads sleeping sickness to human beings?

---

14) How is an endosperm important in a maize grain?

---

15) Briefly explain the term personal hygiene.

---

16) How is wind important to a crop farmer?

---

17) Mention any one process that takes place during rain formation.

---

18) Name any one element of weather.

---

19) Mention any one good quality of a good store.

---

20) Which sense organ do people use for smelling?

---

21) Mention any **one** example of a plant that can be planted in rows.

---

22) Give any one way of preserving cassava at home.

---

23) Give **one** activity in a community that is done to control spread of measles.

---

24a) Mention any **one** type of cloud.

---

b) Give any **two** uses of sunshine to people.

i) \_\_\_\_\_

ii) \_\_\_\_\_

c) In which **one** way can sunshine be dangerous to people?

---

25a) Briefly explain the term harvesting.

---

b) Name any **two** methods of harvesting food stuffs.

i) \_\_\_\_\_

ii) \_\_\_\_\_

c) Give any **one** reason why farmers store food.

---

26a) Mention any **two** conditions needed for rusting to take place.

i) \_\_\_\_\_

ii) \_\_\_\_\_

b) Mention any **two** ways farmers take care of the garden tools.

i) \_\_\_\_\_

ii) \_\_\_\_\_

27a) The diagram below shows a life cycle of an insect.

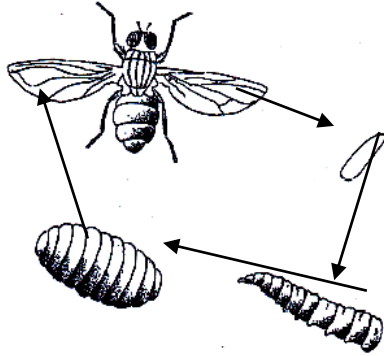

a) Name the stages marked F and H.

i) \_\_\_\_\_ ii) \_\_\_\_\_

b) Give any **two** insects with the kind of life cycle above.

i) \_\_\_\_\_ ii) \_\_\_\_\_

28a) Give the use of a first cotton wool a first aider.

\_\_\_\_\_

b) In which special container do first aiders store their drugs and equipment?

\_\_\_\_\_

c) Give any **two** reasons for giving first aid to casualties.

i) \_\_\_\_\_

ii) \_\_\_\_\_

29a) Match the plant to the part eaten by people correctly .

**plant**

**part eaten**

i) Eggplant

leaves

ii) Cabbage

stem tuber

iii) Sweet potato

fruit

iv) Irish potato

root

**plant**

**part eaten**

i) Egg plant

\_\_\_\_\_

ii) Cabbage

\_\_\_\_\_

iii) sweet potato

\_\_\_\_\_

iv) Irish potato \_\_\_\_\_

30a) What do houseflies use to spread disease germs?

\_\_\_\_\_

b) Name any **two** diseases spread by a housefly.

i) \_\_\_\_\_ ii) \_\_\_\_\_

c) How can the above diseases be controlled?

\_\_\_\_\_

KING FAHAD

# KING FAHAD ISLAMIC PRI. SCH.



## 2021 COVID-19 REVISION WORK - 06

**CLASS : P.4**

**SUBJECT : SOCIAL STUDIES & RELIGIUS EDUCATION**

Name: \_\_\_\_\_ Stream \_\_\_\_\_

1. Name one symbol of a good map.  
\_\_\_\_\_
2. Which traffic light tells drivers to go?  
\_\_\_\_\_
3. Write one duty of the police.  
\_\_\_\_\_
4. Why should a home have a fence?  
\_\_\_\_\_
5. State one cause of road accidents.  
\_\_\_\_\_
6. Write any one role of a father.  
\_\_\_\_\_
7. State any one way of controlling soil erosion in the school compound.  
\_\_\_\_\_
8. Why should a school have a playground?  
\_\_\_\_\_
9. Which animal provides security at home?  
\_\_\_\_\_
10. How useful is a bursar in a school?  
\_\_\_\_\_
11. How can we keep our school clean?  
\_\_\_\_\_
12. Mention any one children's right.

---

13. Give one problem faced by people who live in valleys.

---

14. Why do most farmers plant their crops in the wet season?

---

15. How can school children care for their environment?

---

16. How is a bank important to the people in our community?

---

17. Write one cultural practice in a district.

---

18. Which element of weather is responsible for the water in Lake Victoria?

---

19. Or:- How was the snake responsible for the fall of Adam and Hawa ?

---

20. Or : In which way can a Muslim show obedience to Allah ?

---

21. Or:- In which one way can a child show love to a sick person

---

22. Or: What do we call the day that marks the end of Ramadhan?

---

23. a) Name any **two** things we can use to locate our school .

i) \_\_\_\_\_

ii) \_\_\_\_\_

b) In which **two** ways are schools important to a community?

i) \_\_\_\_\_

ii) \_\_\_\_\_

24. How are the following people important in our division ?

a) Doctor \_\_\_\_\_



- b) Farmer \_\_\_\_\_
- c) Carpenter \_\_\_\_\_
- d) Religious leader \_\_\_\_\_

25. Use the map below to answer question 25.

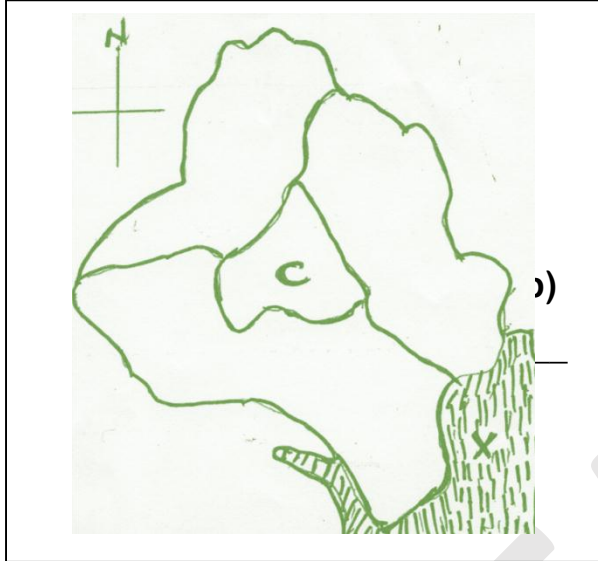

a) Write the title of this map

\_\_\_\_\_

Name the physical feature marked X

\_\_\_\_\_

c) Name the division marked C.

\_\_\_\_\_

d) Which neighbouring district is marked A ? \_\_\_\_\_

26. What are basic needs ?

\_\_\_\_\_

b) State any two basic needs in a home.

i) \_\_\_\_\_

ii) \_\_\_\_\_

c) How do people in our community get basic needs ?

\_\_\_\_\_

27. Match the following correctly .

- a) valley - natural landforms of an area.
- b) plateau - lowland between hills or mountains.
- c) hill - a fairly raised flat topped piece of land.
- d) Physical features - a piece of land raised higher than the area around.

a) Valley \_\_\_\_\_

b) Plateau \_\_\_\_\_

c) Hill \_\_\_\_\_

d) Physical features. \_\_\_\_\_

28. Mention **three** elements of a good map.

i) \_\_\_\_\_

ii) \_\_\_\_\_

iii) \_\_\_\_\_

b) Why are symbols important on a map?

\_\_\_\_\_

29. Or:- What is a prayer?

\_\_\_\_\_

b) Give **two** reasons why Muslims pray?

i) \_\_\_\_\_

ii) \_\_\_\_\_

c) Mention **one** type of prayers.

\_\_\_\_\_

30. Or:-a) Why did Allah create Adam?

i) \_\_\_\_\_

ii) \_\_\_\_\_

b) On which day did Allah create Adam?

\_\_\_\_\_

c) How did Allah punish Adam?

\_\_\_\_\_

# KING FAHAD ISLAMIC PRI. SCH.



## 2021 COVID-19 REVISION WORK - 07

**CLASS : P.4**

**SUBJECT : SOCIAL STUDIES & RELIGIOUS EDUCATION**

Name: \_\_\_\_\_ Stream \_\_\_\_\_

1. Name one member of a nuclear family.

\_\_\_\_\_

2. How is Lake Victoria useful to the people of Kampala?

\_\_\_\_\_

3. Give any one duty of the police.

\_\_\_\_\_

4. Draw a map symbol of a bridge in the space below.



5. What is environment?

\_\_\_\_\_

6. Mention one means of road transport used in your district.

\_\_\_\_\_

7. Name the point of a compass marked a.

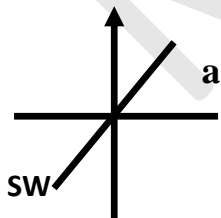

\_\_\_\_\_

8. Give the importance of markets in your district.

---

9. Why do we need a school nurse?

---

10. Draw a road sign showing a zebra crossing.

---

11. Why are trees planted in our school compound?

---

12. Give the importance of a cow to a farmer.

---

13. Which clouds bring rainfall?

---

14. Give one reason for fencing schools.

---

15. State one danger of living in a valley.

---

16. Why do school children put on uniform?

---

17. State one reason why people keep dogs in their homes.

---

18. Which language is commonly used in offices in your district?

---

19. Or: State any one pillar in faith.

---

20. Or: Name any one importance of Adhan.

---

21. Or: Name any one symbol of a Muslim community.

---

22. **Or:** Why do Muslims go for Hijja?

---

23. **Or:** Why do Moslems fast?

---

24. (a) In which season do farmers harvest their crops?

---

(b) State any **two** activities carried out by farmers in the wet season.

i. \_\_\_\_\_

ii. \_\_\_\_\_

(c) How are farmers important in a community?

---

25. (a) What is communication?

---

(b) Give any **one** local means of communication.

---

(c) **Draw and name two means of modern communication.**

26. (a) What is child abuse?

---

(b) Give **two** examples of child abuse practices in your district.

i. \_\_\_\_\_

ii. \_\_\_\_\_

(c) In which **one** way can children help to prevent child abuse?

---

27. Study the map of Kampala below and answer the questions that follow.

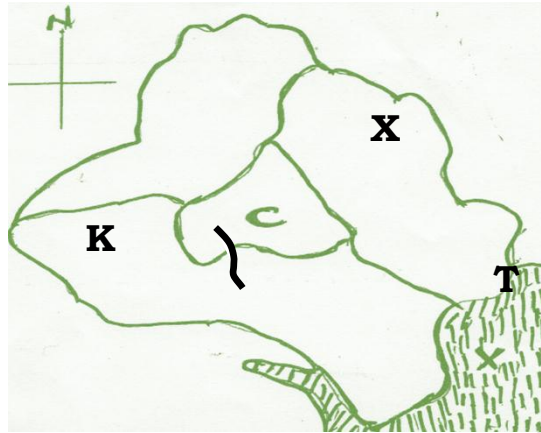

(a) How many divisions make the map above?

\_\_\_\_\_

(b) Name divisions K and X

K \_\_\_\_\_

X \_\_\_\_\_

(c) How is the lake marked T useful to the people of Kampala?

\_\_\_\_\_

28. Or: Match the following correctly

A

Musa

Mohammed

Dauda

Isa

Musa \_\_\_\_\_

Mohammed \_\_\_\_\_

Dauda \_\_\_\_\_

Isa \_\_\_\_\_

B

Injir

Received Tauret

Quran

Zabur

29. **Or:** (a) In how many days did Allah create the world?

---

(b) Why did Allah create human beings?

---

(c) What did Allah create on the days below?

i. First day \_\_\_\_\_

ii. Fifth day \_\_\_\_\_

30. (a) Give any **one** example of a religious leader.

---

(b) State any **three** qualities of a good leader.

i. \_\_\_\_\_

ii. \_\_\_\_\_

iii. \_\_\_\_\_

KING FAHAD

**INQUIRIES:**

<b>ENGLISH</b>	<b>MATHEMATICS</b>	<b>SCIENCE</b>	<b>SOCIAL STUDIES</b>
0702803838	0751496659	0759551042	0772912455
0752650466	0705194277	0703884847	0756441780/0712959424
0755151453		0702322253	0756748597
		0773250150	0788346329
			0701771380

**THEOLOGY:**

<b>QURAN</b>	<b>LUGHA</b>	<b>FIQHU &amp; TARBIA</b>
0701880005	0751467212	0752867638
0705405152	0702199708	0755831209

KING FAHAD