

VICTORIOUS EDUCATION SERVICES

LESSON ACTIVITIES FOR SESSION 2 (Group 3) 2021

LEARNING AREA: 1	Relating with others in an acceptable way.
CLASS:	Baby
ACTIVITY:	3/T001 /4
DURATION:	8 th – 13 th February, 2021.

Date: _____ Stream: _____

Name: _____

Developmental Activity

Naming people I play with.

Listen and say.

(Dear Parent, let your child listen to you, and say the words below after you)

aunt/a/ uncle/u/ friend/f/

Identify people I play with in pictures.



Activity:

1. Tell and colour people in pictures.

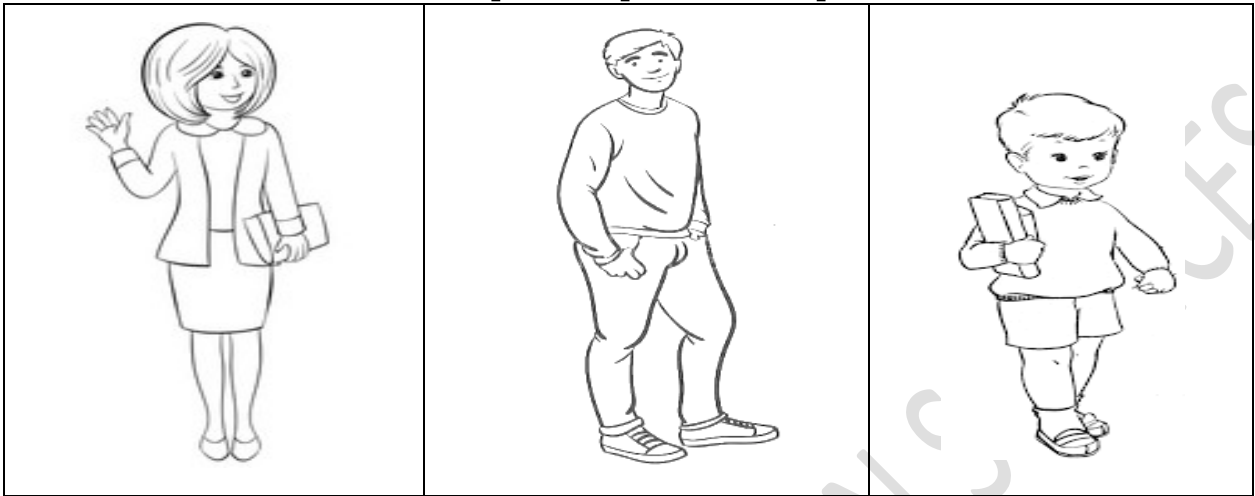

2. Circle the same pictures.

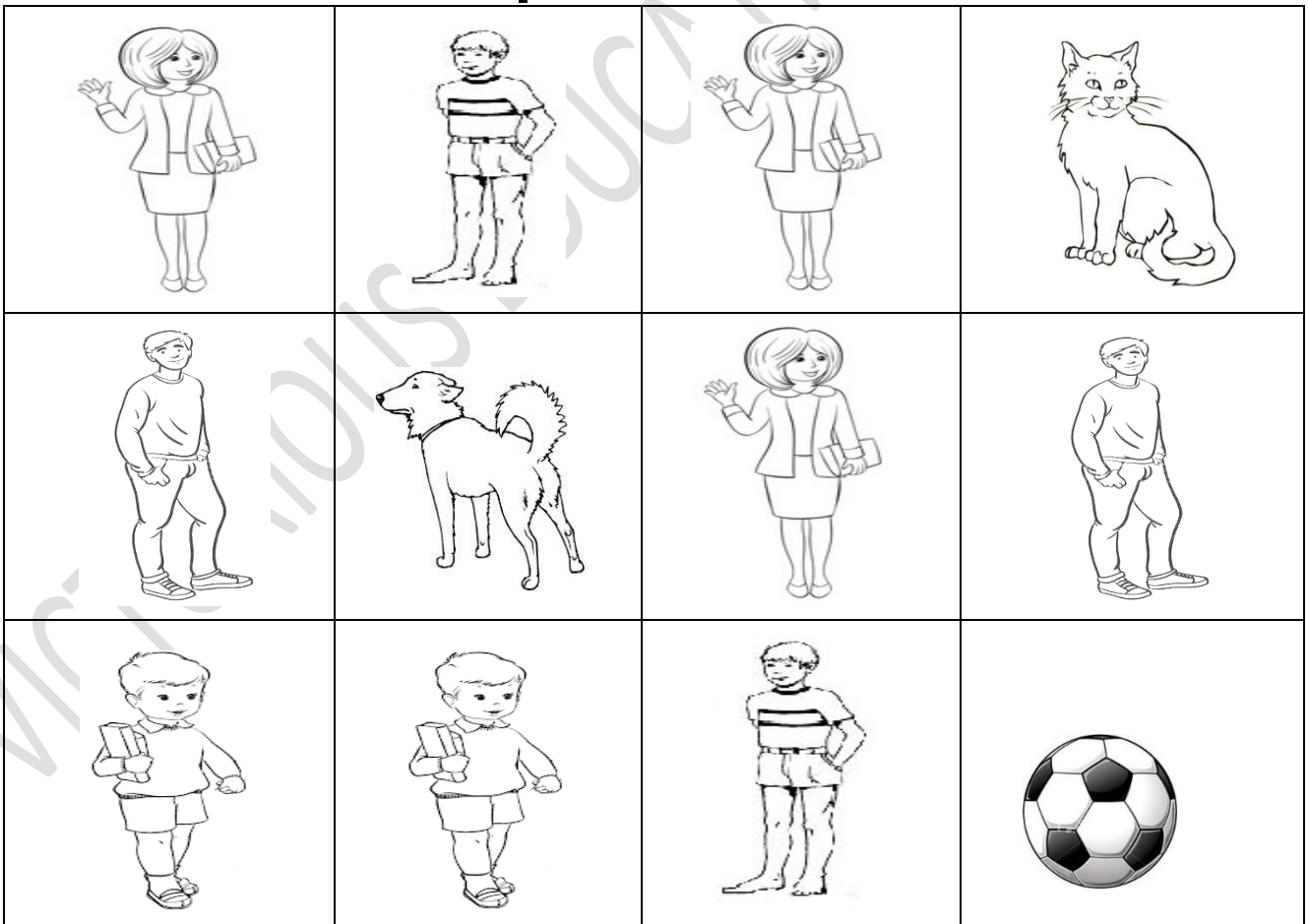

Parent's comment: _____

VICTORIOUS EDUCATION SERVICES

LESSON ACTIVITIES FOR SESSION 2 (Group 3) 2021

LEARNING AREA: 2	Interacting with, exploring, knowing and using my environment.
CLASS:	Baby
ACTIVITY:	3/T002 /4
DURATION:	8 th – 13 th February, 2021.

Date: _____ Stream: _____

Name: _____

Developmental Activity

Drawing objects in a bedroom.

Listen and say.

(Dear Parent, let your child listen to you, and say the words below after you)

bed mattress net blanket pillow

Identify pictures of objects in a bedroom.

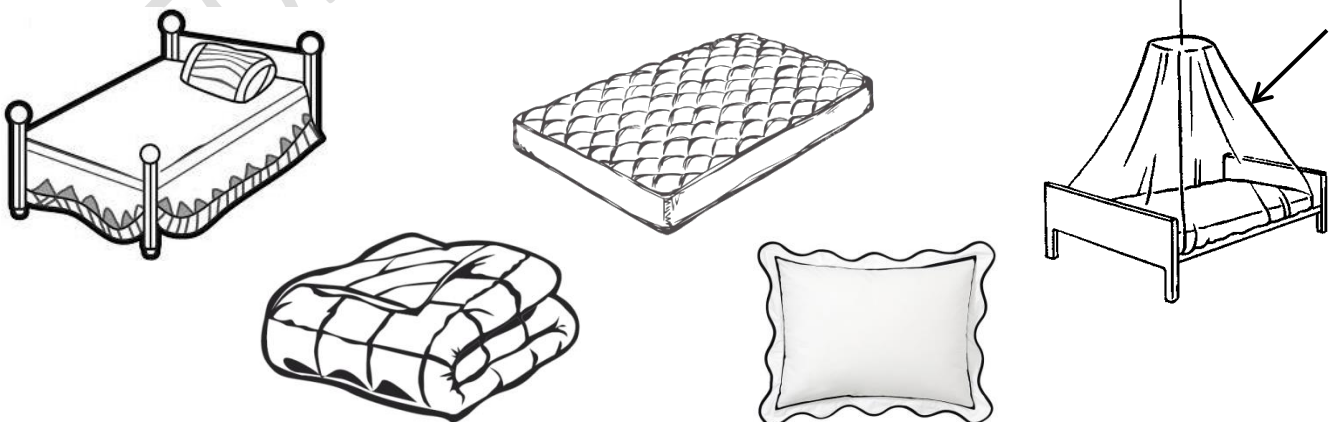

Read pictures of objects in a bedroom.

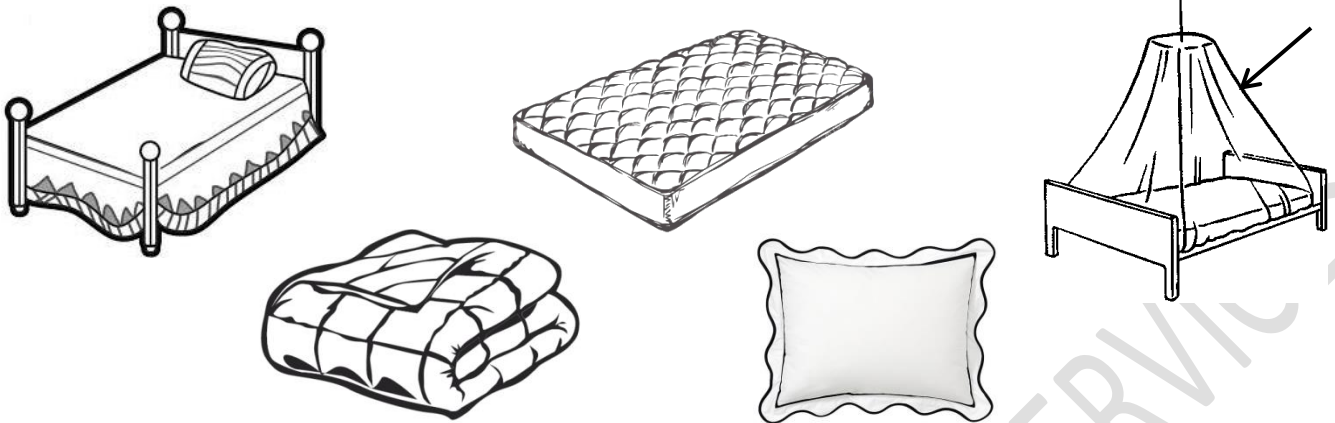

Activity:

1. Read objects in a bedroom.

(Please parent, listen and tick)

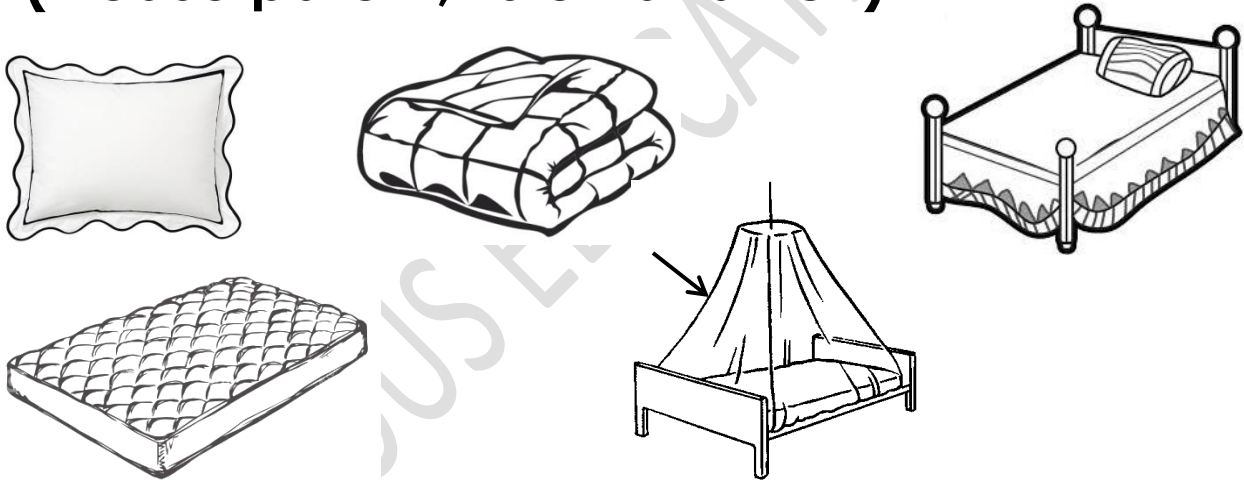

2. Colour pictures of objects in a bedroom.

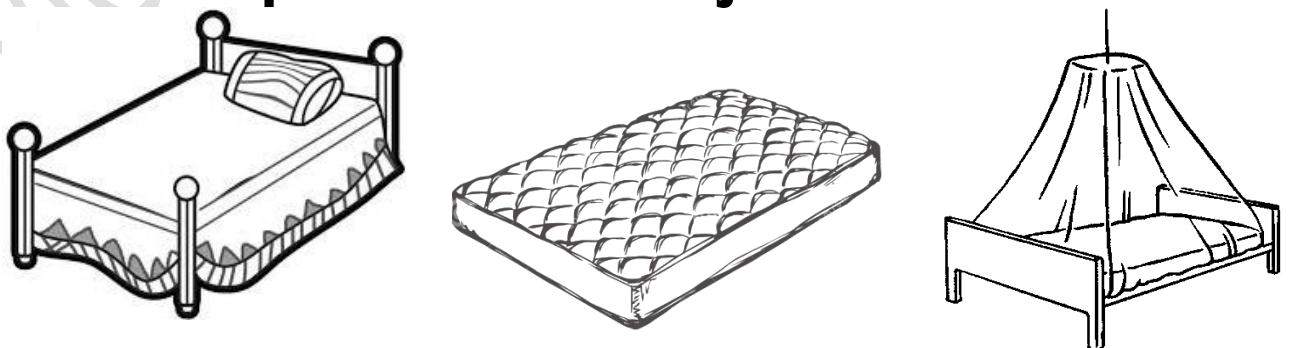

3. Match the same.

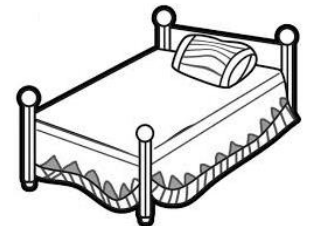
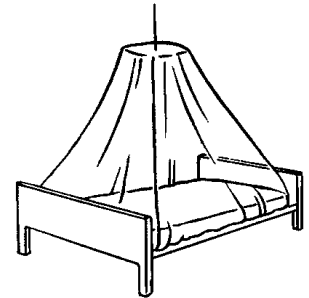
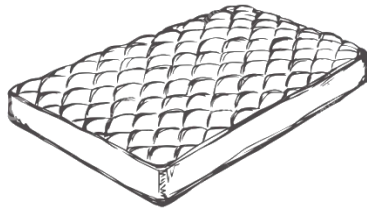
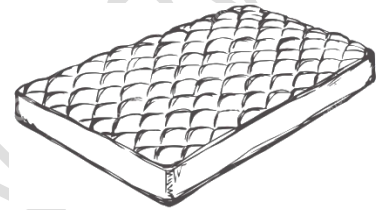
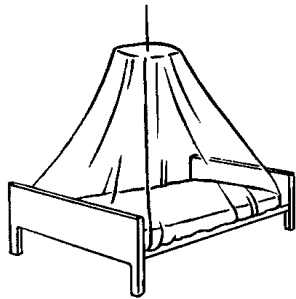
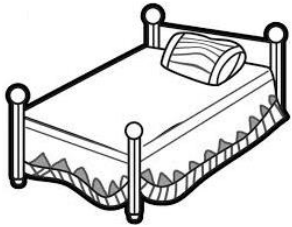

Parent's comment: _____

VICTORIOUS EDUCATION SERVICES

LESSON ACTIVITIES FOR SESSION 2 (Group 3) 2021

LEARNING AREA: 2	Interacting with, exploring, knowing and using my environment.
CLASS:	Baby
ACTIVITY:	3/T002 /4
DURATION:	8 th – 13 th February, 2021.

Date: _____ Stream: _____

Name: _____

Developmental Activity

Feeling smoothness of different objects.

Listen and say.

(Dear Parent, let your child listen to you, and say the word below after you)

smooth /s/

Identify smooth objects in picture.

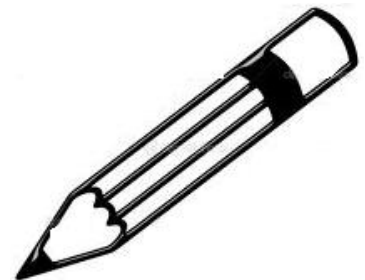
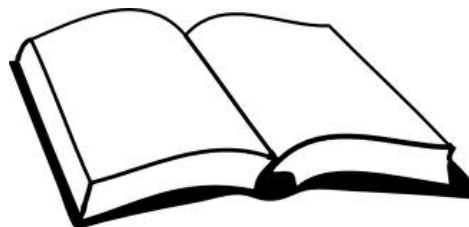
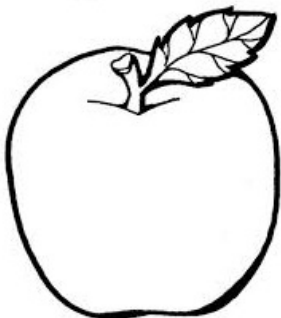

Activity:

1. Colour smooth objects.

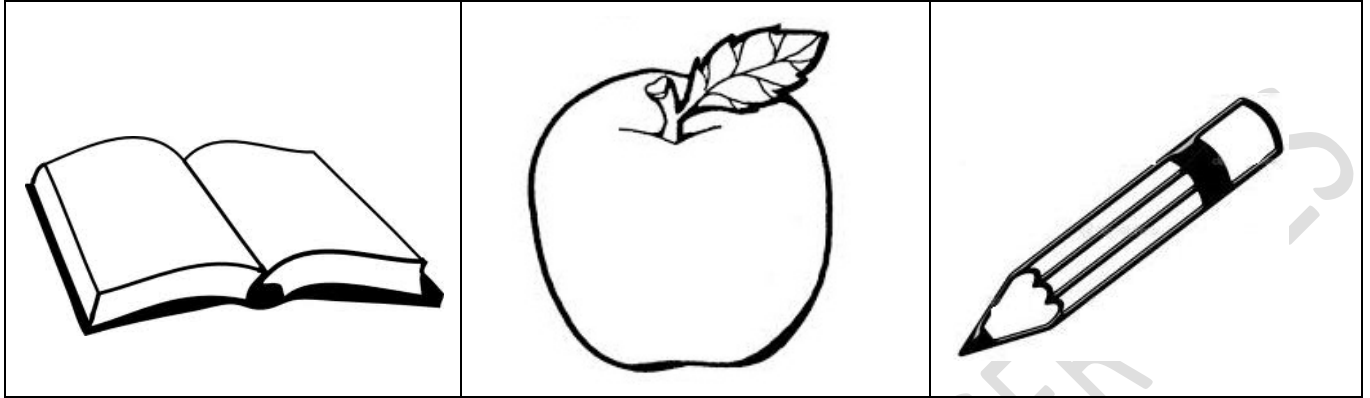

2. Circle smooth objects only.

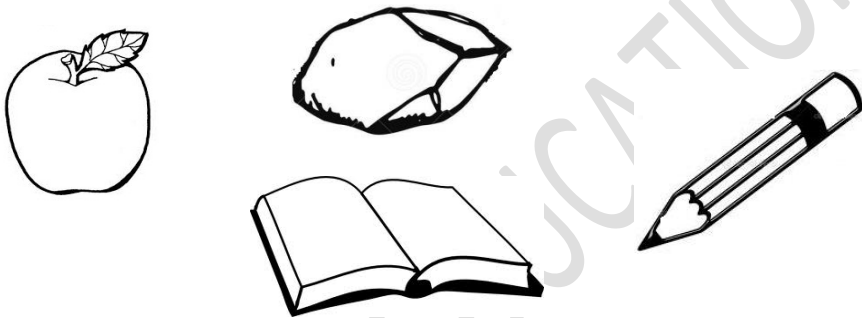

3. Match the same.

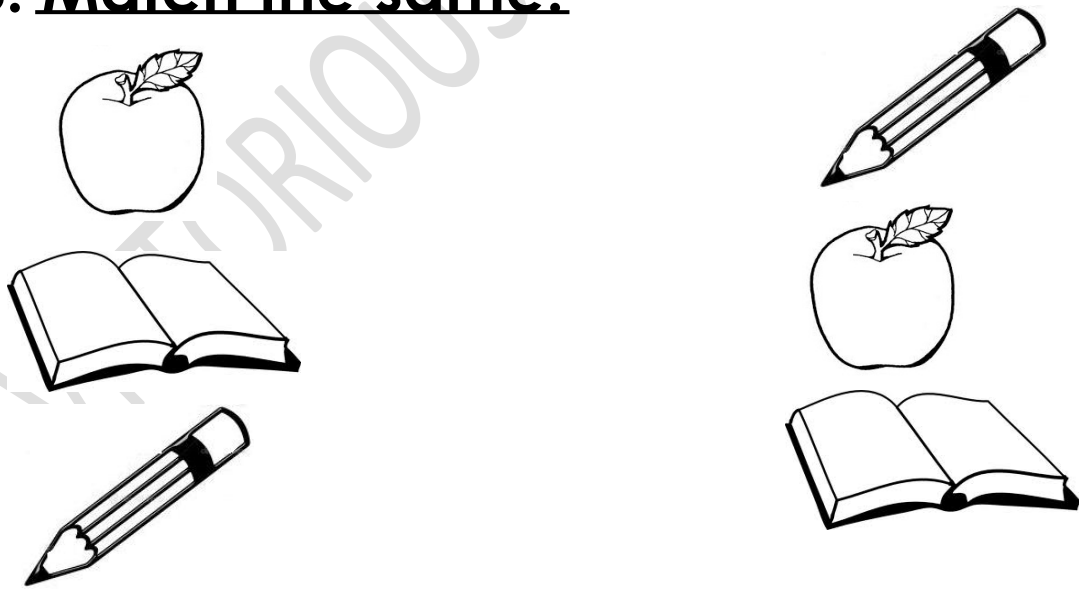

Parent's comment: _____

VICTORIOUS EDUCATION SERVICES

LESSON ACTIVITIES FOR SESSION 2 (Group 3) 2021

LEARNING AREA: 3	Taking care of myself for proper growth and development.
CLASS:	Baby
ACTIVITY:	3/T003 /4
DURATION:	8 th – 13 th February, 2021.

Date: _____ **Stream:** _____

Name: _____

Developmental Activity

Feeling roughness of different objects.

Listen and say.

(Dear Parent, let your child listen to you, and say the word below after you)

rough /r/

Identify rough objects in pictures.



dish sponge



rough wall



sand paper

Activity:

1. Match rough objects.



2. Tick only rough objects.

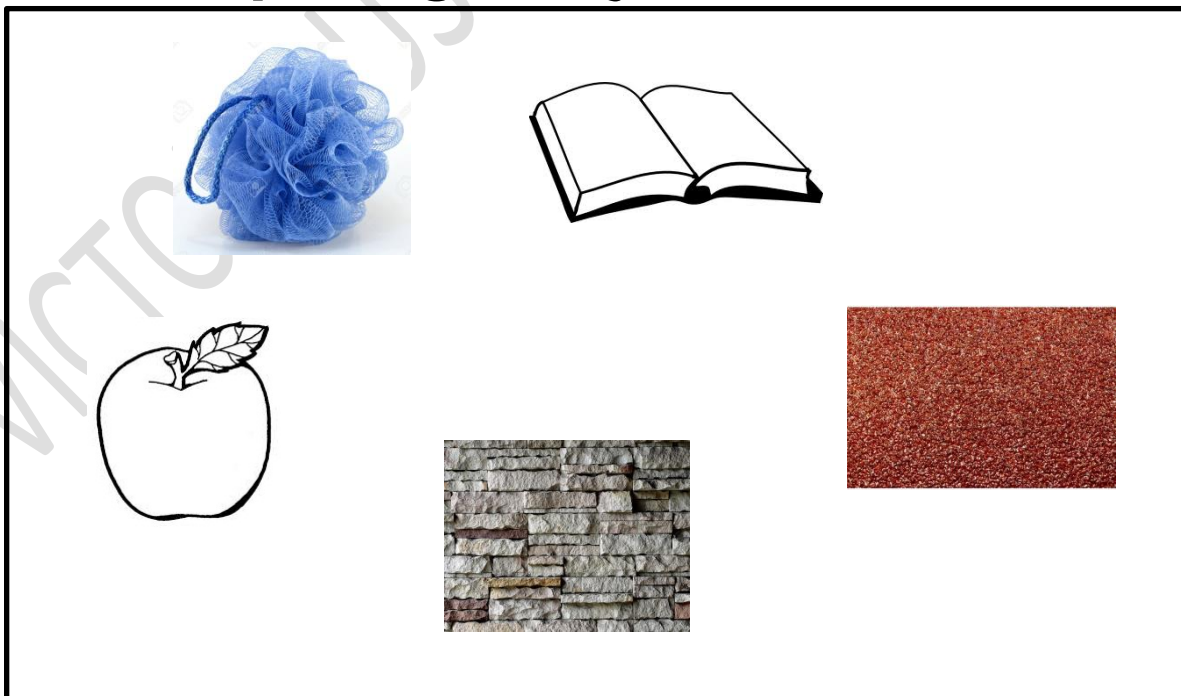

VICTORIOUS EDUCATION SERVICES

LESSON ACTIVITIES FOR SESSION 2 (Group 3) 2021

LEARNING AREA: 4	Developing and using mathematical concepts in my day - to - day experiences.
CLASS:	Baby
ACTIVITY:	3/T004 /4
DURATION:	8 th – 13 th February, 2021.

Date: _____ **Stream:** _____

Name: _____

Developmental Activity

Matching similar shapes.

Listen and say.

(Dear Parent, let your child listen to you, and say the word below after you)

triangle /t/

rectangle /r/

Read the shapes.

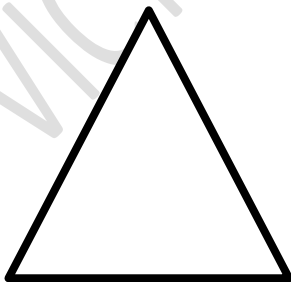

Activity:

1. Match the same shapes.

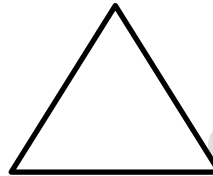
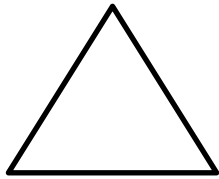

2. Colour the shapes.

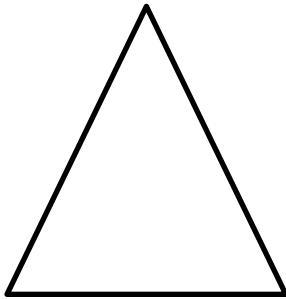

3. Trace the shapes.

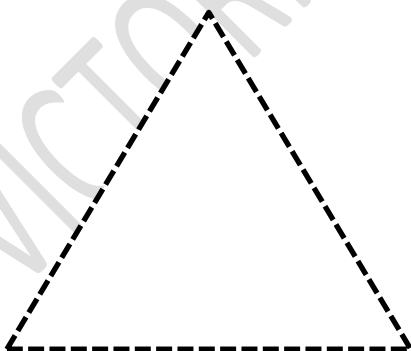

Parent's comment: _____

VICTORIOUS EDUCATION SERVICES

LESSON ACTIVITIES FOR SESSION 2 (Group 3) 2021

LEARNING AREA: 4	Developing and using mathematical concepts in my day - to - day experiences.
CLASS:	Baby
ACTIVITY:	3/T004 /4
DURATION:	8 th – 13 th February, 2021.

Date: _____ **Stream:** _____

Name: _____

Developmental Activity

Reading numbers.

Listen and say.

(Dear Parent, let your child listen to you, and say the words below after you)

duck /d/

ticklish /t/

two /t/

Identify the picture for number 2.

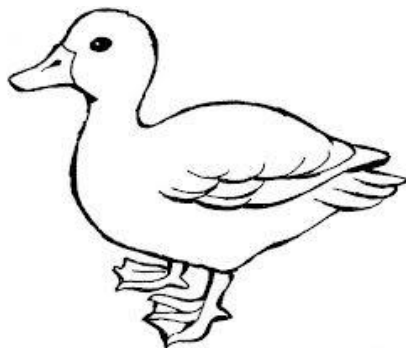

Read and count for 2.

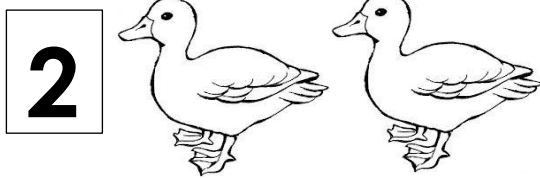

Activity:

1. Colour number 2.



2. Build number 2 using stones/bottle tops/bean seeds etc...

(Please parent guide the child to build number 2)

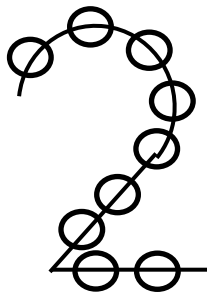

VICTORIOUS EDUCATION SERVICES

LESSON ACTIVITIES FOR SESSION 2 (Group 3) 2021

LEARNING AREA: 4	Developing and using mathematical concepts in my day - to - day experiences.
CLASS:	Baby
ACTIVITY:	3/T004 /4
DURATION:	8 th – 13 th February, 2021.

Date: _____ **Stream:** _____

Name: _____

Developmental Activity

Reading numbers.

Listen and say.

(Dear Parent, let your child listen to you, and say the word below after you)

one /d/ penguin /p/

Identify the picture for number one.

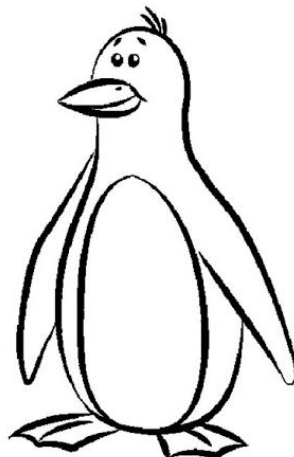

Read the number.

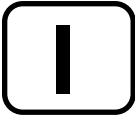

Count for 1.



Activity:

1. Colour number 1 and its picture.



2. Trace.



3. Copy number 1.

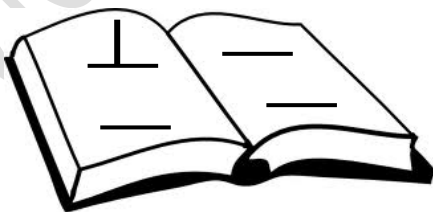

Parent's comment: _____

VICTORIOUS EDUCATION SERVICES

LESSON ACTIVITIES FOR SESSION 11 2020

LEARNING AREA: 5 ₂	Developing and using my language appropriately. (English)
CLASS:	Baby
ACTIVITY:	3/T005 ₂ /4
DURATION:	8 th – 13 th February, 2021.

Date: _____ Stream: _____

Name: _____

Developmental Activity:

Answering simple questions.

Listen and say.

cook /c/ comb /c/

Identify the pictures.



Read pictures in everyday tense.

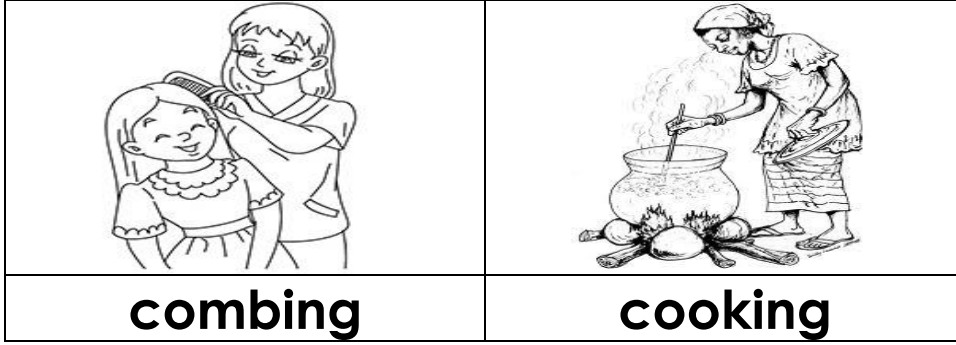

Respond to questions in everyday tense.

Example: What is she doing?

She is



What is she doing?

She is cooking.



What is she doing?

She is combing.

Activity:

1. Colour the pictures.



2. Match the same pictures.



1. Answer correctly.

(Please parent read, listen and tick)

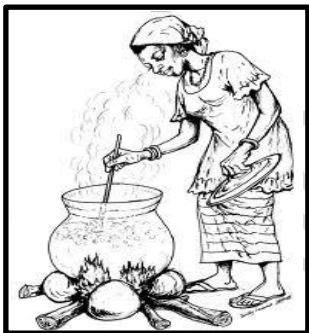

What is she doing?



What is she doing?

Parent's comment: _____

VICTORIOUS EDUCATION SERVICES

LESSON ACTIVITIES SESSION 2, GROUP 3 (2021)

LEARNING AREA: 5 ₁	Developing and using my language appropriately. (Reading)
CLASS:	Baby
ACTIVITY:	03/T005 ₁ /4
DURATION:	8 th – 13 th February, 2021

Date: _____ Stream: _____
Name: _____

Developmental Activity:

Imitating sounds made by objects.

Listen and say.

(Dear Parent, let your child listen to you, and say the words below after you.)

drum /d/

whistle /w/

phone /ph/

car /c/

bell /b/

Identify objects that make sound.

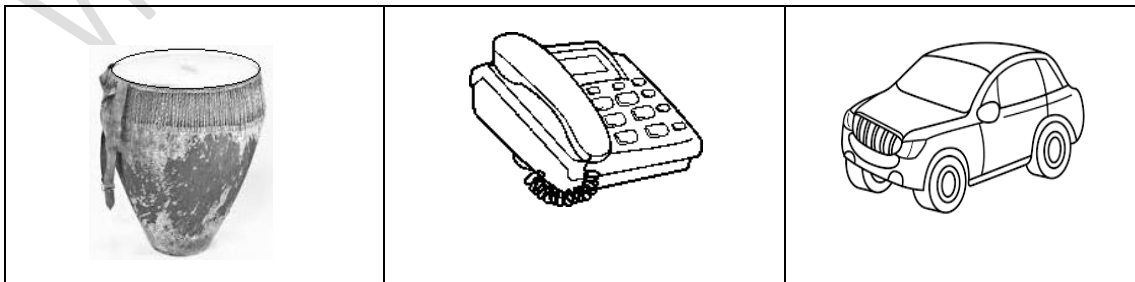

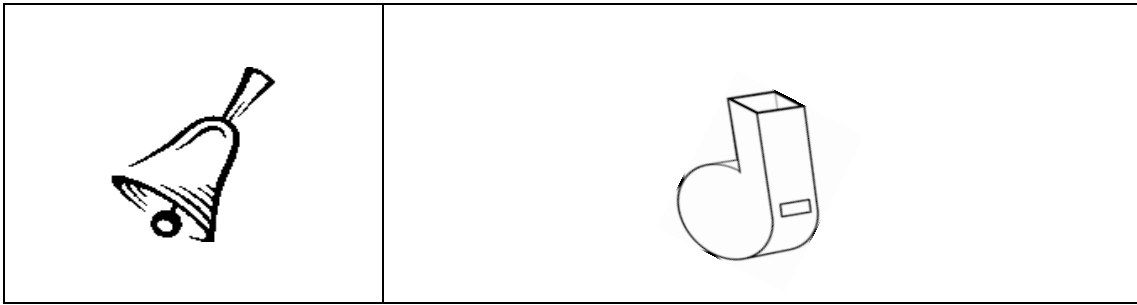

Tell the action in the picture.



Activity:

1. Imitate the sound made by the object.

(Dear parent, listen to your child and mark accordingly.)

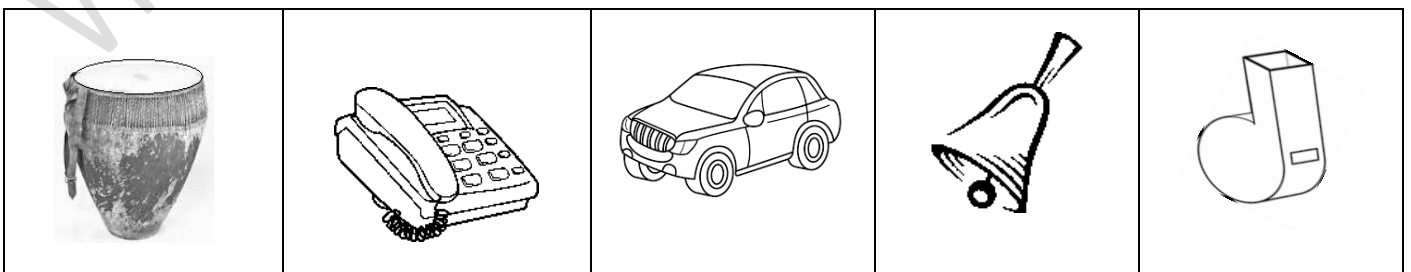

2. Colour the pictures.

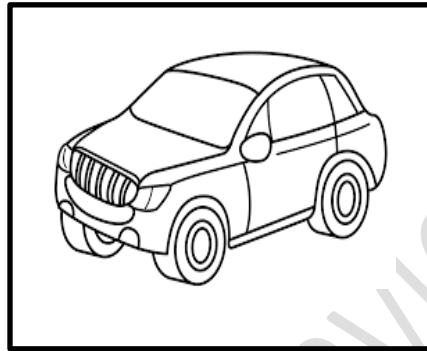

3. Match the same.

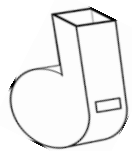

VICTORIOUS EDUCATION SERVICES

LESSON ACTIVITIES SESSION 2, GROUP 3 (2021)

LEARNING AREA: 5 ₁	Developing and using my language appropriately. (Reading)
CLASS:	Baby
ACTIVITY:	03/T005 ₁ /4
DURATION:	8 th – 13 th February, 2021

Date: _____ Stream: _____
Name: _____

Developmental Activity:

Naming the source of sound.

Listen and say.

(Dear Parent, let your child listen to you, and say the words below after you.)

whistle /w/

drum /d/

phone /ph/

dog /d/

cow /c/

Identify things that make sound.

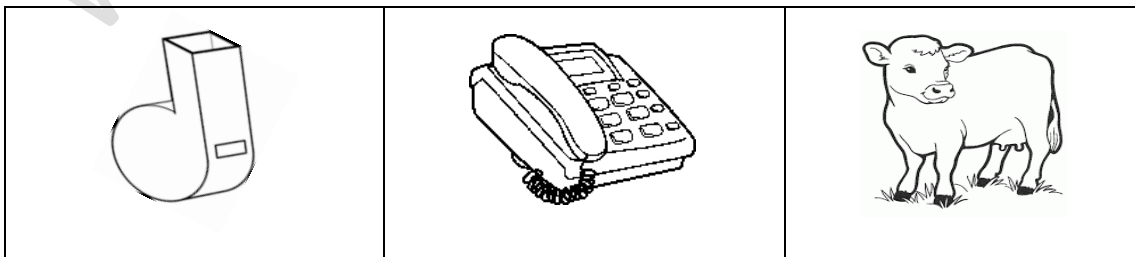

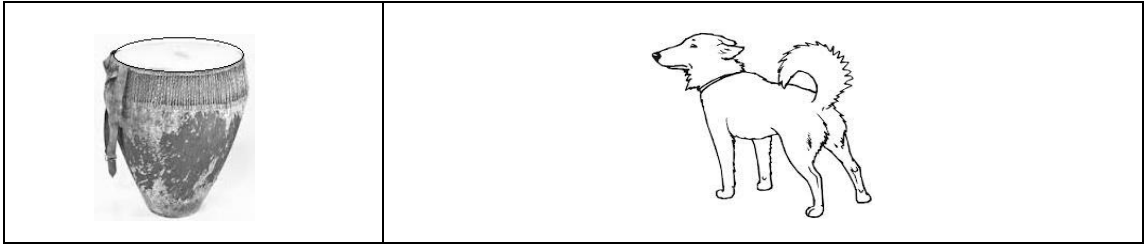

Read and make sounds for the given things.

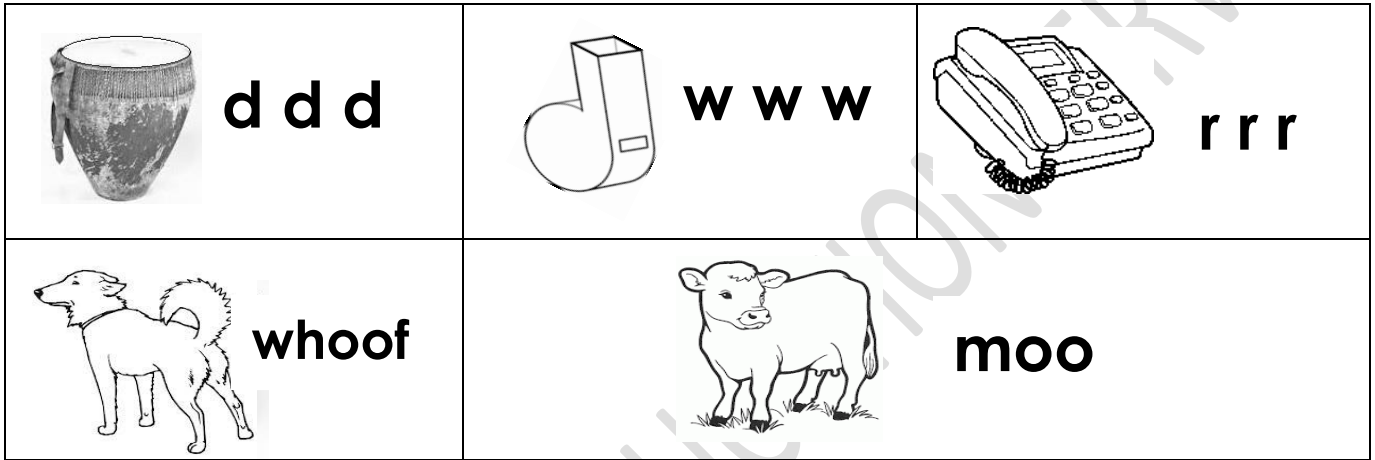

Activity:

1. Tell and colour sources of sound.

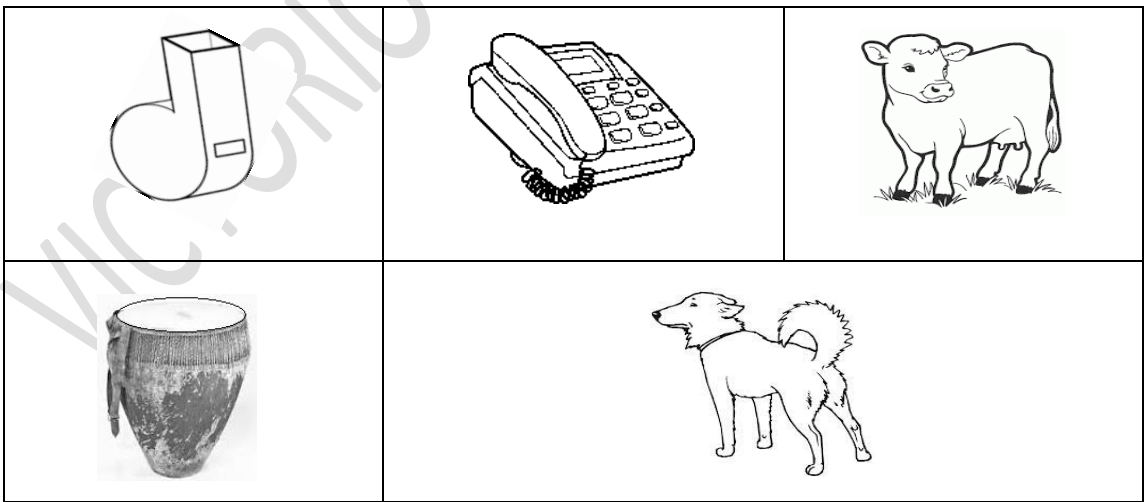

2. Imitate sounds of given pictures.

(Dear parent, listen to your child and mark accordingly.)

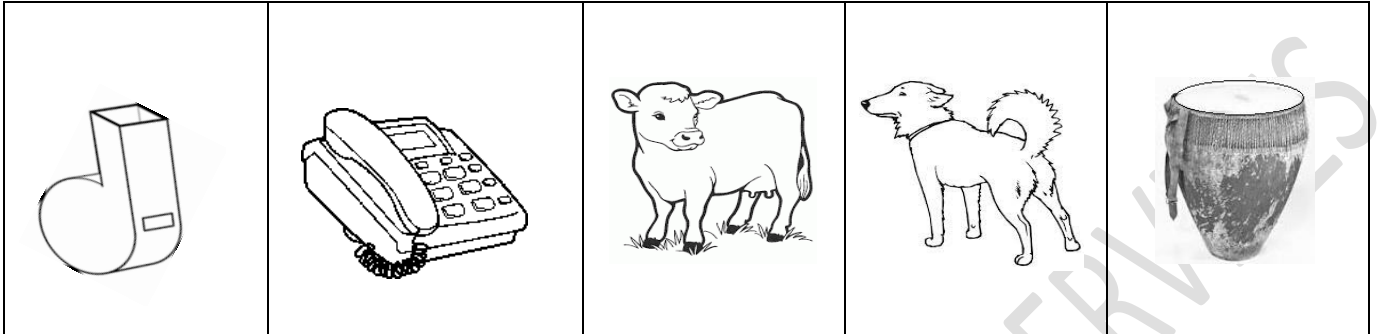

3. Colour the same pictures.

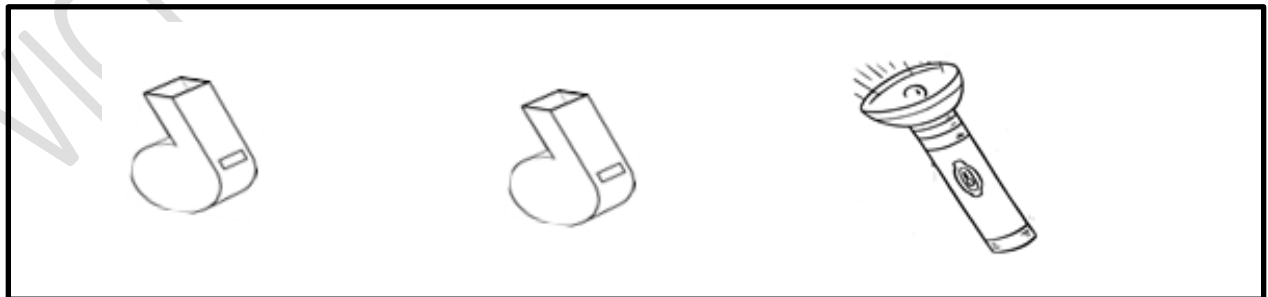
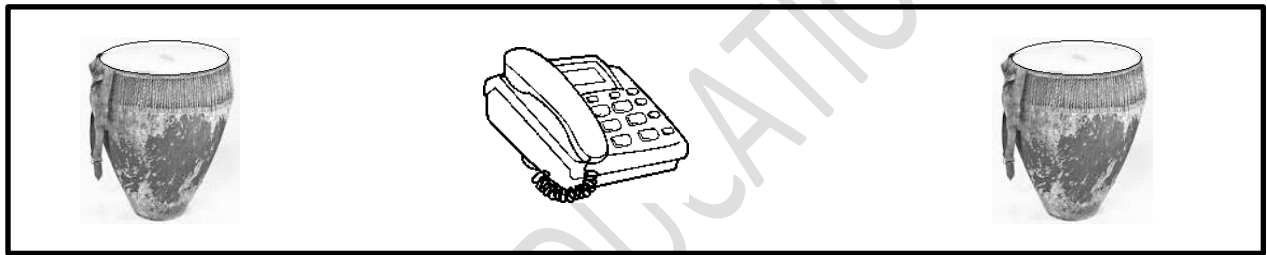

VICTORIOUS EDUCATION SERVICES

LESSON ACTIVITIES SESSION 2, GROUP 3 (2021)

LEARNING AREA: 5 ₁	Developing and using my language appropriately. (Reading)
CLASS:	Baby
ACTIVITY:	03/T005 ₁ /4
DURATION:	8 th – 13 th February, 2021

Date: _____ Stream: _____

Name: _____

Developmental Activity:

Matching similarities in pictures.

Listen and say.

(Dear Parent, let your child listen to you and say the sound below after you.)

/S/

Observe and perform sound action.

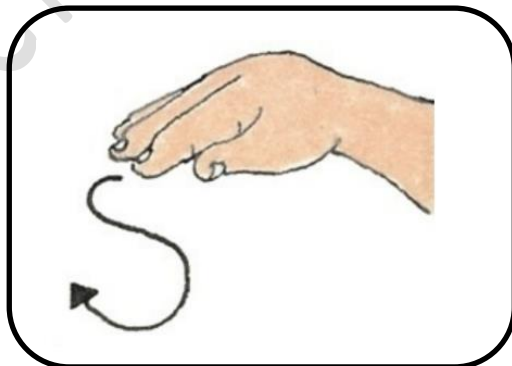

Identify pictures for the sound.

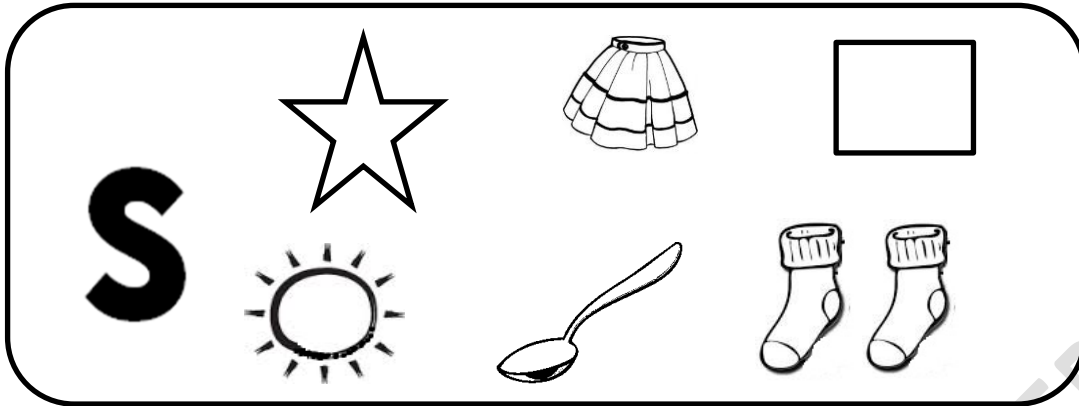

Read the sound.



Identify and form writing symbols.



Activity:

1. Colour the sound.

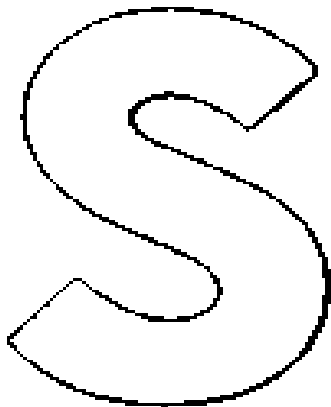

2. Trace.

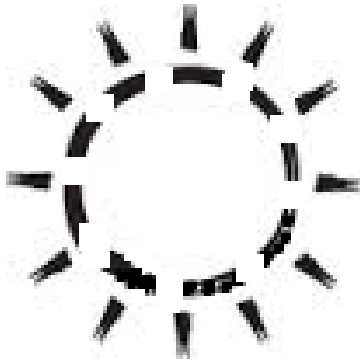

3. Match same pictures.

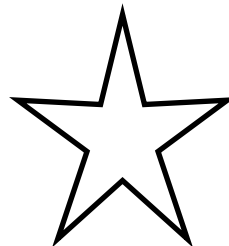
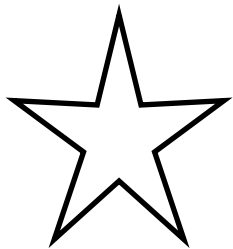

Parent's comment: _____

VICTORIOUS EDUCATION SERVICES

LESSON ACTIVITIES SESSION 2, GROUP 3 (2021)

LEARNING AREA: 5 ₂	Developing and using my language appropriately. (English)
CLASS:	Baby
ACTIVITY:	031/T005 ₂ /4
DURATION	8 th – 13 th February, 2021

Date: _____ Stream: _____

Name: _____

Developmental Activity

Answering simple questions.

Listen, say and read.

(Dear Parent, let your child listen to you, say the sounds and read the pictures below after you)

/c/



/g/



Read the pictures.

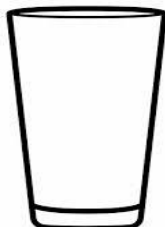

Identify pictures in one form.



a



a



Respond to questions in everyday tense.(orally)

Using: What is this?

This is a



What is this?

This is a clock.



What is this?

This is a glass.

Activity:

1. Read the pictures. (Dear parent, mark accordingly.)



2. Read pictures in one form.

(Dear parent, mark accordingly.)

a



a



3. Oral work

Answer correctly. (Please tick ✓)



What is this?



What is this?

4. Match the same pictures.



Parent's comment: _____